

CF600-3 (Z6)

CF600-6 (Z6 EX)

4 × 4

OWNER'S MANUAL

READ THIS MANUAL CAREFULLY

It contains important safety information



WARNING

Read, understand, and follow all of the instructions and safety precautions in this manual and on all product labels. Failure to follow the safety precautions could result in serious injury or death.

WARNING

The engine exhaust gas from this product contains CO, which is deadly gas and could cause headaches, giddy, or lose consciousness, even death.

A card containing important UTV safety information should be attached to the owner's manual on the next page. If you cannot locate this card or if it has been removed, please contact your dealer.

INTRODUCTION

Thank you for purchasing a CFMOTO vehicle, and welcome to join our worldwide family of CFMOTO owners.

We proudly produce an exciting line of utility and recreational products.

- All terrain vehicle (UTV)
- Utility vehicle (patrol, forest protecting and hunting)
- Motorcycles and scooters

CFMOTO, a company which is specialized in production of liquid-cooled engine, is the top-level supplier in China. Compared to same displacement of air-cooled engine, engine cooling effect is better, oil temperature can be adjusted more freely, more powerful and lower fuel consumption, longer engine working life.

For safe and enjoyable operation of your vehicle, be sure to follow the instructions and recommendations in this owner's manual. Your manual contains instructions for minor maintenance. Information about major repairs are outlined in the CFMOTO service manual, and should be performed only by CFMOTO service dealer and technician.

Your CFMOTO dealer knows your vehicle best and is interested in your total satisfaction. Be sure to return to your dealership for all of your service.

Due to constant improvements in the design and quality of production components, some minor discrepancies may result between the actual vehicle and the information presented in this publication. Depictions and/or procedures in this publication are intended for reference use only.

TABLE OF CONTENTS

VIN No.....	4
Operator safety	5
Features and Controls.....	46
Operation.....	64
Maintenance & Lubrication	87
Clean & Storage	132
Troubleshooting.....	140
Specifications	149
Wiring diagram.....	152

VEHICLE IDENTIFICATION NUMBER

Record your vehicle's identification number and engine serial number in the spaces provided, remove "ignition" key and store it in a safe place for duplicating spare key if keys are lost, otherwise ignition key can only be replaced.

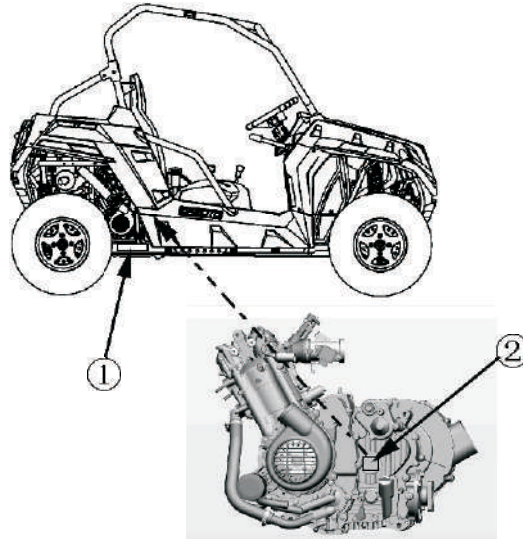

① Vehicle Identification Number: _____

Vehicle model number: _____

② Engine Serial Number: _____

OPERATOR SAFETY

⚠️ WARNING

Failure to heed the warnings contained in this manual can result in serious injury or death. An UTV is not a toy and can be hazardous to operate. This vehicle handles differently from other vehicles, such as motorcycles and cars.

Read this owner's manual. Understand all safety warnings, precautions, and operating procedures before operating an UTV.

A collision or rollover can occur quickly, even during routine maneuvers, like turning, or over obstacles, if you fail to take proper precautions.

AGE RESTRICTIONS

This vehicle is an ADULT VEHICLE ONLY. Operation is prohibited for anyone under the age of 16.

KNOW YOUR VEHICLE

As the operator of the vehicle, you are responsible for your personal safety, the safety of others, and the protection of our environment. Read and understand your owner's manual, which includes valuable information about all aspects of your vehicle, including safe operating procedures.

OPERATOR SAFETY

SAFETY TRAINING

When you purchased your new UTV, your dealer offered a hands-on safety-training course that covers all aspects of vehicle safety. You were also provided with printed materials that explain safe operating procedures. You should review this information on a regular basis. If you purchased a used UTV from a party other than a dealer, you can request this free safety training from any authorized dealer.

Familiarize yourself with all laws and regulations concerning the operation of this vehicle in your area. We strongly advise you to strictly follow the recommended maintenance program outlined in your owner's manual. This preventive maintenance program is designed to ensure that all critical components on your vehicle are thoroughly inspected at specific intervals. The following signal words and symbols appear throughout this manual and on your UTV. Your safety is involved when these words and symbols are used. Become familiar with their meanings before reading the manual.

WARNING

The safety alert symbol below indicates a potential personal injury hazard or death and or damage to the vehicle.

OPERATOR SAFETY

⚠ CAUTION

A caution indicates a situation that may result in damage to the vehicle.

⚠ CAUTION

A note will alert you to important information or instructions.

⚠ WARNING

Serious injury or death can result if you don't follow these instructions and procedures, which are outlined in further detail within your owner's manual.

- Read this manual and all labels carefully, and follow the operating procedures described.
- Never operate an UTV without proper instruction. Take a training course. Beginners should receive training from a certified instructor. Contact an authorized UTV dealer to find out about the training courses nearest you.
- Never allow anyone under 16 years of age to operate this UTV.
- Never carry a passenger under age 12. Make sure any passenger is tall enough to comfortably and safely reach the hand holds and place both feet on the floor.
- Never permit a guest to operate the UTV unless the guest has read this manual and all product labels and has completed a certified safety-training course.
Never operate an UTV without wearing an approved helmet that fits properly. Always wear eye protection (goggles or face shield), gloves, boots, a long- sleeved shirt or jacket, and long pants.
- Never consume alcohol or drugs before or while operating an UTV.

OPERATOR SAFETY

- Never operate at excessive speeds. Travel at speeds appropriate for the terrain, visibility and operating conditions, and your experience.
- Always keep hands and feet inside vehicle.
- Always inspect your UTV before each use to make sure it is in safe operating condition.
- Always follow the inspection and maintenance procedures and schedules outlined in your owner's manual.
- Never allow a passenger to ride in the cargo box. Never carry more than one passenger.
- Always travel slowly and use extra caution when operating on unfamiliar terrain.
- Be alert to changing terrain conditions.
- Never operate on excessively rough, slippery, or loose terrain.
- Always follow proper turning procedures as described in this manual. Practice turning your UTV at low speeds, before attempting to turn at faster speeds. Do not turn at excessive speeds.
- Always have the UTV inspected by an authorized dealer if it's been involved in an accident.
- Never operate on hills too steep for the UTV or for your abilities. Practice on smaller hills before attempting larger hills.
- Always follow proper procedures for climbing hills. Check the terrain carefully before ascending a hill.
- Never climb hills with excessively slippery or loose surfaces. Shift your weight forward.
- Never open the throttle suddenly or make sudden gear changes. Never go over the top of a hill at high speed.

OPERATOR SAFETY

- Always follow proper procedures for going downhill and for braking on hills. Check the terrain carefully before you start down a hill. Shift your weight backward.
- Never go down a hill at high speed.
- Avoid going down a hill at an angle, which would cause the vehicle to lean sharply to one side. Travel straight down the hill when possible.
- Always follow proper procedures for crossing the side of a hill. Avoid hills with excessively slippery or loose surfaces. Shift your weight to the uphill side of the UTV. Never attempt to turn the UTV around on any hill until you have mastered (on level ground) the turning technique outlined in this manual.
- Avoid crossing the side of a steep hill when possible.
- Always use proper procedures if you stall or roll backwards while climbing a hill. To avoid stalling, maintain a steady speed when climbing a hill. If you stall or roll backwards, follow the special procedure for braking described in this manual.
- Always dismount on the uphill side, or to either side if the UTV is pointed straight uphill. Turn the UTV around and remount following the procedure described in this manual.
- Always check for obstacles before operating in a new area. Never attempt to operate over large obstacles, such as rocks or fallen trees. Always follow proper procedures when operating over obstacles as described in this manual.
- Always be careful of skidding or sliding. On slippery surfaces like ice, travel slowly and use extra caution to reduce the chance of skidding or sliding out of control.

OPERATOR SAFETY

- Avoid operating the UTV through deep or fast-flowing water. If it is unavoidable, travel slowly, balance your weight carefully, avoid sudden movements, and maintain a slow and steady forward motion.
- Do not make sudden turns or stops, and do not make sudden throttle changes.
- Wet brakes may have reduced stopping ability. Test your brakes after leaving water. If necessary, apply them lightly several times to allow friction to dry out the pads.
- Always check for obstacles or people behind the UTV before operating in reverse. When it is safe to proceed in reverse, move slowly and avoid turning at sharp angles.
- Always use the size and type of tires specified for your UTV, and always maintain proper tire pressure.
- Never modify an UTV through improper installation or use of accessories.
- Never exceed the stated load capacity for your UTV. Cargo must be properly distributed and securely attached. Reduce speed and follow the instructions in this manual for carrying cargo or towing. Allow a greater distance for braking.
- Always remove the ignition key when the vehicle is not in use to prevent unauthorized use or accidental starting.
- Riders should wear seat belts at all times. Seat belts reduce the severity of injury in the event of sudden stop or accident.
- Never touch running parts, such as wheels, drive shaft, etc.

OPERATOR SAFETY

Always keep both hands on the steering wheel during operation. A passenger should always be seated in the passenger seat with both feet on the floor and both hands firmly grasping securely the hand holds.

This vehicle handles differently than cars, trucks or other off-road vehicles. Turning improperly can result in an overturn. Avoid sharp turns. Never turn while applying heavy throttle. Never make abrupt steering maneuvers. Operate at speeds appropriate for your skills, the conditions, and terrain. Do not do power slides, “donuts”, jumps or other driving stunts.

Always turn off the engine before refueling. Make sure the refueling area is well ventilated and free of any source of flame or sparks. Gasoline is extremely flammable. See page 29 for fuel safety warnings. Remove flammable material containers from the box before filling.

FOR MORE INFORMATION ABOUT UTV SAFETY, PLEASE CONTACT WITH YOUR DEALER.

OPERATOR SAFETY

EQUIPMENT MODIFICATIONS

We are concerned with the safety of our customers and for the public. Therefore, we strongly recommend that consumers do not install on an UTV any equipment that may increase the speed or power of the vehicle, or make any other modifications to the vehicle for these purposes. Any modifications to the original equipment of the vehicle create a substantial safety hazard and increase the risk of body injury. The warranty on your UTV is terminated if any equipment has been added to the vehicle, or if any modifications have been made to the vehicle, that increases its speed or power.

NOTE

The addition of certain accessories, including (but not limited to) mowers, blades, tires, sprayers, or large racks, may change the handling characteristics of the vehicle. Use only approved accessories and familiarizes yourself, with their function, and effect on the vehicle.

OPERATOR SAFETY

⚠️WARNING

POTENTIAL HAZARD

Operating this vehicle without proper instruction.

WHAT CAN HAPPEN

Loss of control and accident resulting in serious injury or death.

HOW TO AVOID THE HAZARD

The risk of an accident is greatly increased if the operator does not know how to operate the vehicle properly in different situations and on different types of terrain.

All operators must read and understand the owner's manual and all warning and instruction labels before operating the vehicle.

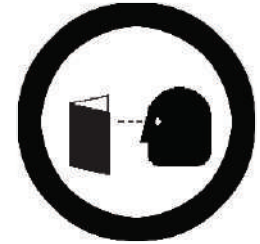

⚠️WARNING

POTENTIAL HAZARD

Turning improperly

WHAT CAN HAPPEN

Loss of control, accident, or overturn resulting in serious injury or death.

HOW TO AVOID THE HAZARD

Avoid sharp turns. Never turn while applying heavy throttle. Never make abrupt steering maneuvers. Operate at speeds appropriate for your skills, the conditions, and the terrain. **DO NOT** do power slides, “donuts”, jumps or other driving stunts. Practice turning at slow speeds before attempting to turn at faster speeds.

OPERATOR SAFETY

⚠️WARNING

POTENTIAL HAZARD

Riding in this vehicle without wearing the seat belt.

WHAT CAN HAPPEN

Serious injury or death in the event of an accident or sudden stop.

HOW TO AVOID THE HAZARD

Always make sure the seat belts are secured for both the operator and passenger before riding.

⚠️WARNING

POTENTIAL HAZARD

Failure to follow the minimum age recommendations for this vehicle.

WHAT CAN HAPPEN

Serious injury or death (the child or others)

HOW TO AVOID THE HAZARD

Operation is prohibited for anyone under 16 years of age or anyone without a valid driver's license. Never operate with a passenger under the age of 12. Make sure any passenger is tall enough to comfortably and safely reach the handholds and place both feet on the floor.



OPERATOR SAFETY

⚠️WARNING

POTENTIAL HAZARD

Riding this vehicle without wearing an approved helmet and eye protection.

WHAT CAN HAPPEN

Head injury, eye injury or death in the event of an accident.

HOW TO AVOID THE HAZARD

Operator and passenger: Always wear an approved helmet that fits properly. Always wear eye protection (goggles or face shield).



⚠️WARNING

POTENTIAL HAZARD

Riding this vehicle after consuming alcohol or drugs.

WHAT CAN HAPPEN

Accident resulting in serious injury or death due to affected judgment, balance and perception and slower reaction time.

HOW TO AVOID THE HAZARD

Never consume alcohol or drugs before or while riding this vehicle.

OPERATOR SAFETY

⚠️WARNING

POTENTIAL HAZARD

Removing hands from the steering wheel or handholds or removing feet from the floor while riding.

WHAT CAN HAPPEN

Loss of control and accident resulting in serious injury or death.

HOW TO AVOID THE HAZARD

The operator should always keep both hands on the steering wheel during operation. A passenger should securely grasp the handholds and plant both feet firmly on the floor.

⚠️WARNING

POTENTIAL HAZARD

Failure to inspect the vehicle before operating, failure to properly maintain the vehicle.

WHAT CAN HAPPEN Accident, equipment damage?

HOW TO AVOID THE HAZARD

Always inspect your vehicle before each use to make sure it's in safe operating condition.

Always follow the inspection and maintenance procedures and schedules described in the owner's manual.



OPERATOR SAFETY

⚠️WARNING

POTENTIAL HAZARD

Using accessories not approved by CFMOTO for use on this vehicle.

WHAT CAN HAPPEN

Loss of control, accident, or overturn resulting in serious injury or death.

HOW TO AVOID THE HAZARD

Never operate with accessories not approved by CFMOTO for use on this vehicle. Non-approved accessories may seriously affect vehicle stability.

⚠️WARNING

POTENTIAL HAZARD

Operating this vehicle on paved surfaces, including sidewalks, paths, parking lots, and driveways.

WHAT CAN HAPPEN

Loss of control and accident resulting in serious injury or death.

HOW TO AVOID THE HAZARD

This vehicle's tires are designed for off-road use only, not for use on pavement. Paved surfaces may seriously affect handling and control of the vehicle, and may cause the vehicle to go out of control.

Avoid operating the vehicle on pavement. If you must operate on a paved surface, travel slowly and do not make sudden turns or stops.



OPERATOR SAFETY

OPERATOR SAFETY

POTENTIAL HAZARD

Operating this vehicle on public streets, roads or highways.

WHAT CAN HAPPEN

Collision with another vehicle.

HOW TO AVOID THE HAZARD

Never operate this vehicle on any public street, road, or highway, including dirt or gravel.

In many areas it's illegal to operate vehicles of this type on public streets, roads, and highways.



⚠️ WARNING

POTENTIAL HAZARD

Improperly operating over obstacles.

WHAT CAN HAPPEN

Loss of control or overturn resulting in serious injury or death or death.

HOW TO AVOID THE HAZARD

Before operating in a new area, check for obstacles.

Avoid operating over large obstacles such as rocks and fallen trees when possible. If unavoidable, use extreme caution and operate slowly.

OPERATOR SAFETY

⚠️WARNING

POTENTIAL HAZARD

Skidding or sliding.

WHAT CAN HAPPEN

Loss of control, accident, or overturn resulting in serious injury or death

HOW TO AVOID THE HAZARD

Always follow proper procedures for operating on slippery surfaces as described in the owner's manual. When operating on slippery surfaces such as ice or loose gravel reduce speed and use extra caution to reduce the chance of skidding or sliding out of control.

Do not operate on excessively slippery surfaces.



⚠️WARNING

POTENTIAL HAZARD

Operating through deep or fast-flowing water.

WHAT CAN HAPPEN

Loss of traction, loss of control, overturn, or accident resulting in serious injury or death.

HOW TO AVOID THE HAZARD

Always follow proper procedures for operating in water as described in the owner's manual.

Never operate in fast-flowing water or in water that exceeds the recommended maximum depth.

OPERATOR SAFETY

⚠️WARNING

POTENTIAL HAZARD

Improperly operating in reverse.

WHAT CAN HAPPEN

Collision with an obstacle or person, resulting in severe injury or death.

HOW TO AVOID THE HAZARD

Always follow proper procedures for operating in reverse as described in the owner's manual.

Before shifting into reverse gear, always check for obstacles or people behind the vehicle. When it is safe to proceed, back slowly.

Avoid making sharp turns in reverse.

⚠️WARNING

POTENTIAL HAZARD

Overloading the vehicle or carrying/towing cargo improperly.

WHAT CAN HAPPEN

Loss of control, accident due to instability and changes in vehicle handling.

HOW TO AVOID THE HAZARD

Always follow the instructions in the owner's manual for carrying cargo or pulling a trailer.



OPERATOR SAFETY

Never exceed the stated load capacity for this vehicle. Cargo should be properly distributed and securely attached. Reduce speed when carrying cargo or pulling a trailer. Allow a greater distance for braking.

▲WARNING

POTENTIAL HAZARD

Operating this vehicle with improper tires or with improper or uneven tire pressure

WHAT CAN HAPPEN

Loss of control, accident or overturn resulting in serious injury or death.

HOW TO AVOID THE HAZARD

Always use the size and type of tires specified for your vehicle. Always maintain proper tire pressure.



OPERATOR SAFETY

⚠️WARNING

POTENTIAL HAZARD

Climbing hills improperly

WHAT CAN HAPPEN

Loss of control or overturn resulting in serious injury or death.

HOW TO AVOID THE HAZARD

Always follow proper procedures for climbing hills as described in the owner's manual.

Always check the terrain carefully before ascending a hill.

Avoid climbing steep hills (15° maximum).

Use extreme caution when operating on hills, and follow proper operating procedures outlined in the owner's manual.

Never climb hills with excessively slippery or loose surfaces. Never open the throttle suddenly.

Never go over the crest of a hill at high speed. An obstacle, a sharp drop, or another vehicle or person could be on the other side of the hill.

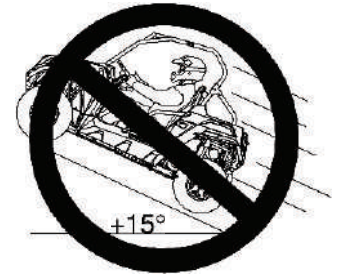

OPERATOR SAFETY

⚠️WARNING

POTENTIAL HAZARE

Traveling downhill improperly.

WHAT CAN HAPPEN

Loss of control or overturn resulting in serious injury or death.

HOW TO AVOID THE HAZARD

Always follow proper procedures for traveling down hills as described in the owner's manual.

Always descend a hill with the transmission in forward gear.

Never descend a hill with the transmission in neutral.

Always check the terrain carefully before descending a hill. Never travel down a hill at high speed.

Avoid traveling down a hill at an angle, which would cause the vehicle to lean sharply to one side.

Travel straight downhill.

⚠️WARNING

POTENTIAL HAZARD

Crossing hills and turning on hills.

WHAT CAN HAPPEN

Loss of control or overturn resulting in serious injury or death.

HOW TO AVOID THE HAZARD

Avoid operating on steep hills (15° maximum).

Avoid crossing the side of a hill.

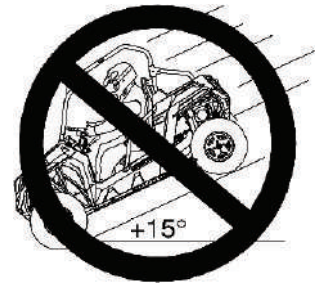

OPERATOR SAFETY

⚠️ WARNING

POTENTIAL HAZARD

Stalling, rolling backwards while climbing a hill.

WHAT CAN HAPPEN

Loss of control or overturn resulting in serious injury or death.

HOW TO AVOID THE HAZARD

Maintain a steady speed when climbing a hill. If you lose all forward speed:

Apply the brakes gradually until the vehicle is fully stopped.

Place the transmission in reverse and slowly allow the vehicle to roll straight downhill while applying light brake pressure to control speed.



⚠️ WARNING

POTENTIAL HAZARD

Operating on excessively rough, slippery or loose terrain.

WHAT CAN HAPPEN

Loss of control, accident or overturn resulting in serious injury or death.

HOW TO AVOID THE HAZARD

Do not operate the UTV on extremely rough, slippery, or loose terrain.



OPERATOR SAFETY

⚠️WARNING

POTENTIAL HAZARD

Operating this vehicle at excessive speeds.

WHAT CAN HAPPEN

Loss of control and accident resulting in serious injury or death.

HOW TO AVOID THE HAZARD

Operate at speeds appropriate for your skills, the conditions, and the terrain.



⚠️WARNING

POTENTIAL HAZARD

Attempting jumps and other stunts.

WHAT CAN HAPPEN

Loss of control, accident, or overturn resulting in serious injury or death

HOW TO AVOID THE HAZARD

Never attempt jumps and other stunts. Avoid exhibition driving.

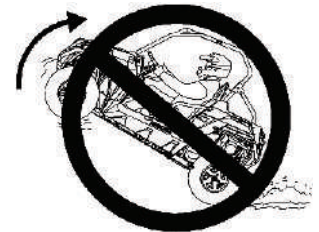

OPERATOR SAFETY

⚠️WARNING

POTENTIAL HAZARD

Operating on frozen bodies of water.

WHAT CAN HAPPEN

Severe injury or death if the vehicle and/or riders fall through the ice.

HOW TO AVOID THE HAZARD

Never operate this vehicle on a frozen body of water.



⚠️WARNING

POTENTIAL HAZARD

Failure to use extra caution when operating this vehicle on unfamiliar terrain.

WHAT CAN HAPPEN

Loss of control or overturn resulting in serious injury or death.

HOW TO AVOID THE HAZARD

Travel slowly and use extra caution when operating on unfamiliar terrain.

Always be alert to changing terrain.

OPERATOR SAFETY

⚠️WARNING

POTENTIAL HAZARD

Carrying a passenger in the cargo box.

WHAT CAN HAPPEN

Serious injury or death due to a fall from the vehicle or contact with moving components.

HOW TO AVOID THE HAZARD

Never allow a passenger to ride in the cargo box.

⚠️WARNING

POTENTIAL HAZARD

Operating with more than one passenger.

WHAT CAN HAPPEN

Loss of control and accident resulting in serious injury or death.

HOW TO AVOID THE HAZARD

Never carry more than one passenger.

Additional passengers can affect the operator's ability to steer and operate the controls.



OPERATOR SAFETY

⚠️WARNING

Operating a damaged vehicle can result in an accident with serious injury or death. After any overturn or accident, have a qualified service dealer inspect the entire vehicle for possible damage, including (but not limited to) brakes, throttle and steering systems.

⚠️WARNING

Exhaust system components are very hot during and after use of the vehicle. Hot components can cause serious burns and fire. Do not touch hot exhaust system components. Always keep combustible materials away from the exhaust system. Use caution when traveling through tall grass, especially dry grass.

⚠️WARNING

Leaving the keys in the ignition can lead to unauthorized use of the vehicle resulting in serious injury or death. Always remove the ignition key when the vehicle is not in use.

OPERATOR SAFETY

⚠️WARNING

- Gasoline is highly flammable and is explosive under certain conditions. Always exercise extreme caution whenever handling gasoline.
- Always stop the engine when refueling.
- Always refuel outdoors or in a well-ventilated area.
- Remove flammable material containers from the box before filling.
- Do not smoke or allow open flames or sparks in or near the refueling area or where gasoline is stored. Never refuel while a person is in the vehicle.
- Do not over fill the tank. Do not fill the tank neck.
- If gasoline spills on your skin or clothing, immediately wash it off with soap and water and change clothing. Never start the engine or let it run in an enclosed area. Gasoline powered engine exhaust fumes are poisonous and can cause loss of consciousness and death in a short time.



OPERATOR SAFETY

SAFETY DECALS AND LOCATIONS

Warning decals have been placed on your vehicle for your protection. Read and follow the instructions of the decals on the vehicle very carefully. If any of the decals depicted on the vehicle in this manual differ from the decals on your vehicle, always read and follow the instructions of decals on your vehicle.

(1) CARGO BOX WARNING (2) TOWING LOAD WARNING

▲WARNING

- Passengers can be thrown off. This can cause serious injury or death.
- Never carry passengers in cargo box.
- Max. load of cargo box : 100kg
- Towing bracket vertical load : 50kg, Towing load : 125kg (including cargo)

(3) TIRE PRESSURE AND OVERLOAD WARNING

Improper tire, tire pressure, or overloading can cause loss of control resulting in SEVERE INJURY OR DEATH.

TIRE PRESSURE: PSI (KPA)

Front tire : 10 (70) Rear tire: 12 (84)

OPERATOR SAFETY

MAXIMUM WEIGHT CAPACITY:

Including driver, passenger, cargo and accessories : 250kg

Reduce speed and allow greater distance for braking when carrying cargo. Overloading or carrying tall, off-center or unsecured loads will increase your risk of loss of control.

Loads should be centered and carried as low as possible in box. For stability on rough or hill terrain, reduce speed and cargo. Be careful if load extends over the side of box.

CAB FRAME, WARNING

▲WARNING

ALWAYS WEAR YOUR SEAT BELT (1)

●Operator and passenger must wears a seat belt.

VEHICLE OVERTURN can cause severe injury or death.

●The cab frame is not designed or intended for rollover protection.

SHIFT CAUTION

To avoid transmission damage, shift only when the vehicle is stationary or at idle.



OPERATOR SAFETY

When vehicle is stopped, place shift in the parked position.

AGE WARNING

Operating this vehicle if you are under the age of 16, increases your chances of severe injury or death. Never operate this vehicle if you are under the age of 16 or without a valid driver's license.

OVERTURN WARNING

Improper operation can cause this vehicle to overturn and lead to serious injury or death.

This vehicle handles differently than cars, trucks, or other off-road vehicles. In order to avoid overturns:

- Avoid sharp turns
- Never turn while applying heavy throttle.
- Never make abrupt steering maneuvers.
- Operate at speeds appropriate to your skills and the conditions of the terrain.
- Don't do power slides, "donut jumps", or other jumping stunts.

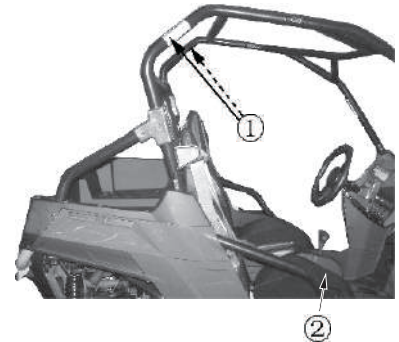

OPERATOR SAFETY

PRE-RIDE WARNING

(1) DRIVING WARNING

Always use approved helmet and protective gear for the operator and passenger. Never drive vehicle while on alcohol and drugs. Improper use of vehicle can result in SEVERE INJURY or DEATH.

NEVER OPERATE :

- Without first reading and understanding the safety guide.
- With more than one passenger.
- On hills steeper than 15 degrees.
- On paved surfaces; pavement may seriously affect handling and control.
- With Non-CFMOTO genuine parts or accessories; they may seriously affect stability.

ALWAYS :

- Keep hands and feet inside vehicle.
- Reduce speed and use extra caution when carrying a passenger.
- Operate slowly in reverse; avoid sharp turns or sudden braking.
- Make sure the passenger reads and understands all safety labels.
- Watch out for branches or other hazardous material that could enter the vehicle.

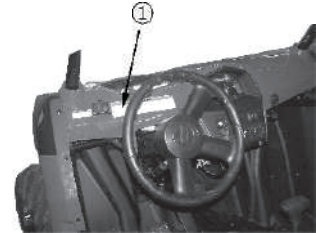

OPERATOR SAFETY

Locate and read Owner's Manual. Follow all instructions and warnings. If the Owner's Manual is missing; contact the CFMOTO dealer for detailed information.

PRE-RIDE WARNING

(1) 4WD OPERATION WARNING

- Must stop or place in idle, when changing from 2WD or 4WD, to avoid damage of transmission parts
- When Diff-lock is locked, it will enhance vehicles maneuverability, please keep speed low and allow enough braking distance to avoid going out of control.

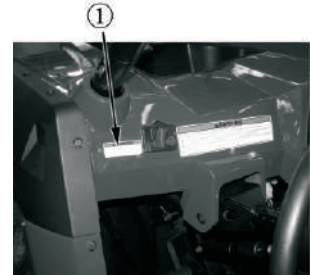

(2) AIR FILTER VENTILATOR WARNING

- Do not cover air filter ventilator, to avoid damage to the engine.
- Keep air smoothly entering the ventilator.



OPERATOR SAFETY

FAILURE TO FOLLOW THE WARNINGS CONTAINED IN THIS MANUAL CAN RESULT IN SEVERE INJURY OR DEATH. YOUR CFMOTO VEHICLE IS NOT A TOY AND CAN BE HAZARDOUS TO OPERATE. THIS VEHICLE HANDLES DIFFERENTLY THAN CARS, TRUCKS, OR OTHER OFF-ROAD VEHICLES. A COLLISION OR ROLLOVER CAN OCCUR QUICKLY EVEN DURING ROUTINE MANEUVERS LIKE TURNING, OR DRIVING ON HILLS OR OVER OBSTACLES IF YOU TAKE IMPROPER PRECAUTIONS.

READ AND UNDERSTAND YOUR OWNER'S MANUAL AND ALL WARNINGS BEFORE OPERATING THE VEHICLE.

ALWAYS HEED THE FOLLOWING INSTRUCTIONS AND PROCEDURES WHICH ARE OUTLINED FURTHER DETAILS WITHIN YOUR OWNER'S MANUAL.

- Read this manual and all labels carefully. Follow the operating procedures as described.
- Never carry a passenger until you have operated this vehicle at least 2 hours and have completed the New Operator's driving procedures outlined on pages 71-73.
- Operation is prohibited for anyone under 16 years of age or anyone without a valid driver's license.
- Never carry a passenger under age 12. Make sure any passenger is tall enough to place both feet on the floor, and reach the handholds comfortably and safely.
- Riders should wear seat belts at all times. Seat belts reduce the severity of injury, in the event of a sudden stop or accident.
- Helmet and eye protection are required for both operator and passenger, at all times.

OPERATOR SAFETY

- Always keep hands and feet inside vehicle.
- Never allow a passenger to ride in the cargo box. Never carry more than one passenger.
- Never permit a guest to operate this vehicle unless the guest has read this manual and all product labels, and has completed the New Operator's driving procedures outlined on pages 71-73.
- To reduce tip over risk, be especially careful when encountering obstacles, slopes, and braking on hills or during turns.
- Never operate with Non-CFMOTO genuine accessories which may seriously affect vehicle's stability, and cause the vehicle to overturn.
- This vehicle handles differently than cars, trucks or other off-road vehicles. Turning improperly can result in an overturn. Avoid sharp turns. Never turn while applying heavy throttle. Never make abrupt steering maneuvers. Operate at speeds appropriate for your skills, the conditions, and terrain. Do not do power slides, "donuts", jumps, or other driving stunts.
- Never operate at excessive speeds. Always travel at speed appropriate for your skills, your passenger's skills, and operation conditions.
this vehicle is for off-road only. Never operate on public roads and always avoid paved surfaces.
- Never use drugs or alcohol before or during driving.
- Always inspect your vehicle each time before driving, to make sure it's in safe operating condition. Always follow the inspection, maintenance procedures, and schedules described in this manual.
- Always keep both hands on the steering wheel during operation. A passenger should always be seated in the passenger seat with both feet on the floor and both hands

OPERATOR SAFETY

firmly and securely grasping the hand holds.

- Always travel slowly and pay extra attention when driving on unfamiliar terrain. Be alert to changing terrain.
- Never operate on excessively rough, slippery, and loose terrain.
- Always follow properly turning procedures described in this manual. Practice turning at low speeds before attempting turns at higher speeds.
- Always have this vehicle checked by an authorized CFMOTO dealer, if it has been involved in an accident.
- Always follow proper procedures for climbing hills, as described in this manual. Check the terrain carefully, before attempt to climb a hill. Never climb hills with excessively slippery or loose surfaces. Never open throttle suddenly or make sudden gear changes. Never go over the top of hill at high speeds.
- Always follow the proper procedures outlined in this manual for traveling downhill and for braking on hills. Check the terrain carefully before descending a hill.
- Never travel downhill at high speeds.
- Avoid going downhill at an angle which would cause the vehicle to lean sharply to one side. Travel straight down the hill where possible.
- Avoid crossing the side of a hill.
- Always check for obstacles before operating in a new area.
- Never attempt to operate over large obstacles such as rocks or fallen trees.
- Always follow the proper procedures outlined in this manual when operating over obstacles. Always be careful of skidding or sliding. On slippery surfaces such as ice; travel slowly and exercise caution to reduce the chance

OPERATOR SAFETY

of skidding or sliding out of control.

- Never operate in fast flowing water or in water that exceeds the recommended maximum depth (see page 79). Wet brakes may have reduced stopping ability. To dry out brake pads, apply the brakes lightly several times while driving slowly.
- Always be sure there are no obstacles or people behind your vehicle when operating in reverse. When it's safe to proceed in reverse, move slowly.
- Avoid making sharp turns in reverse.
- Always use the proper size and type of tires specified for your vehicle.
- Always maintain proper tire pressure.
- Never exceed stated load capacity for this should be vehicle. Cargo should be properly distributed and securely attached. Reduce speed and follow the instructions in this manual for hauling cargo or pulling a trailer. Allow a greater distance for braking.
- Always turn off the engine before refueling. Make sure the refueling area is well ventilated and free of any source of flame or sparks. Gasoline is extremely flammable. See page 29 for fuel safety warnings. Remove flammable material containers from the box before filling.
- Always remove the ignition key when the vehicle is not in use to prevent unauthorized use or accidental starting.

FOR MORE INFORMATION ABOUT SAFETY, PLEASE CONTACT WITH YOUR DISTRIBUTOR.

OPERATOR SAFETY

EQUIPMENT MODIFICATIONS

⚠️WARNING

MODIFICATIONS TO YOUR VEHICLE MAY NEGATIVELY IMPACT VEHICLE STABILITY AND RESULT IN SERIOUS INJURY OR DEATH. FAILURE OF CRITICAL MACHINE COMPONENTS MAY RESULT FROM OPERATION WITH ANY MODIFICATIONS, ESPECIALLY THOSE THAT INCREASE SPEED OR POWER. THIS VEHICLE MAY BECOME LESS STABLE AT SPEEDS HIGHER THAN THOSE FOR WHICH IT IS DESIGNED. LOSS OF CONTROL MAY OCCUR AT HIGHER SPEEDS. YOUR VEHICLE IS DESIGNED TO PROVIDE SAFE OPERATION WHEN USED AS DIRECTED. DO NOT MAKE ANY MODIFICATIONS TO THIS VEHICLE. NEVER OPERATE WITH ACCESSORIES NOT APPROVED BY CFMOTO FOR USE ON THIS VEHICLE. THE OPERATOR MUST CHECK ALL SAFETY COMPONENTS BEFORE EACH RIDE. MAKE SURE YOUR VEHICLE IS IN EXCELLENT OPERATING CONDITION AT ALL TIMES.

EQUIPMENT MODIFICATIONS We are concerned for the safety of our customers and for the general public. Therefore, we design accessories for your vehicle that take into consideration safe vehicle handling and stability. Never operate with accessories not approved by CFMOTO for use on this vehicle. Non-approved accessories may seriously affect vehicle stability and could cause the vehicle to overturn.

Do not install on a CFMOTO vehicle any equipment that may increase the speed or power of the vehicle, or make any other modifications to the vehicle for these purposes. Any modifications to the original equipment of the vehicle create a substantial safety hazard and increase the risk of bodily injury.

OPERATOR SAFETY

The warranty on your vehicle is terminated if any equipment has been added to the vehicle, or if any modifications have been made to the vehicle, that increases its speed or power.

⚠ NOTE

The addition of certain accessories, including (but not limited to) mowers, blades, tires, sprayers, or large racks, may change the handling characteristics of the vehicle. Use only CFMOTO approved accessories, and familiarize yourself with their function and effect on the vehicle.

OPERATOR SAFETY

SAFE RIDING GEAR

Always wear appropriate clothing when riding a CFMOTO vehicle. Wear protective clothing for comfort and to reduce the chance of injury.

OPERATOR SAFETY

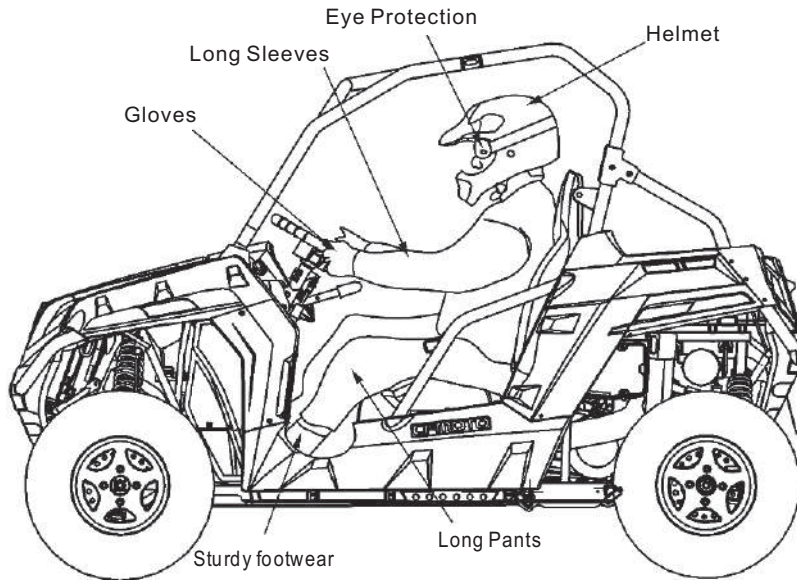

OPERATOR SAFETY

SAFE RIDING GEAR

HELMET

Wearing a helmet can prevent a severe head injury. Whenever riding this CFMOTO vehicle, always wear a helmet that meets or exceeds established safety standards.

Approved helmets in the USA and Canada bear a U.S. Department of Transportation (DOT) label.

Approved helmets in Europe, Asia, and Oceania bear the ECE 22.05 label and the E-Mark label.

EYE PROTECTION

Do not depend on eyeglasses or sunglasses for eye protection. Whenever riding a CFMOTO vehicle, always wear shatterproof goggles or use a shatterproof helmet face shield. CFMOTO recommends wearing approved Personal Protective Equipment (PPE) bearing markings such as VESC or CE. Make sure protective eyewear is kept clean.

Gloves

Wear gloves for comfort and for protection from sun, cold weather and other elements.

Boots

Wear sturdy footwear. Do not ride a CFMOTO vehicle with bare feet.

Clothing

Wear long sleeves and long pants to protect arms and legs.

OPERATOR SAFETY

AGE RESTRICTIONS

This vehicle is an **ADULT VEHICLE ONLY**. Operation is prohibited for anyone under 16 years of age or anyone without a valid driver's license. Never operate with a passenger under the age of 12. Make sure any passenger is tall enough to comfortably and safely reach the handhold and place both feet on the floor.

KNOW YOUR VEHICLE

As the operator of the vehicle, you are responsible for your personal safety, the safety of others (including your passenger), and the protection of our environment. Read and understand your owner's manual, which includes valuable information about all aspects of your vehicle, including safe operating procedures.

We strongly advise you to strictly follow the recommended maintenance program outlined in your owner's manual. This preventive maintenance program is designed to ensure that all critical components on your vehicle are thoroughly inspected at specific intervals.

OPERATOR SAFETY

KNOW YOUR RIDING AREA

Your CFMOTO vehicle is an off-road vehicle. Familiarize yourself with all laws and regulations concerning the operation of this vehicle in your area.

Respect the environment in which you ride your vehicle. Find out where the designated riding areas are by contacting your CFMOTO dealer, a local riding club, or local officials.

Help keep our trails open for recreational vehicle use. Operate with respect for the terrain, avoid littering, and always stay on the designated trails.

TRAIL ETIQUETTE

Always practice good etiquette when riding. Allow a safe distance between your vehicle and other vehicles operating in the same area.

Communicate to oncoming operators by signaling the number of vehicles in your group. When stopping, move your vehicle to the edge of the trail as far as possible to allow others to pass safely.

FEATURES AND CONTROLS

Your vehicle is equipped with cab nets on both sides of the vehicle. Cab nets must be used by both operator and passenger at all times. Promptly replace worn or damaged parts with new ones available at your authorized CFMOTO dealer.

▲NOTE

The vehicle illustrated below is shown without cab nets only to allow component identification.

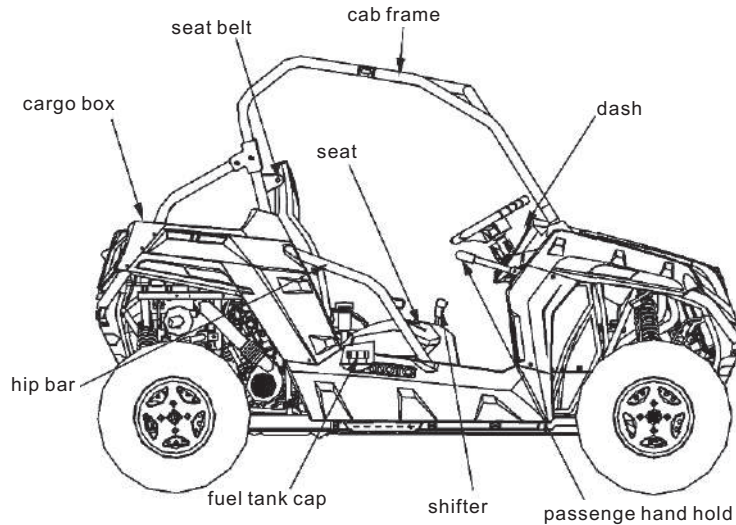

FEATURES AND CONTROLS

COMPONENT LOCATIONS

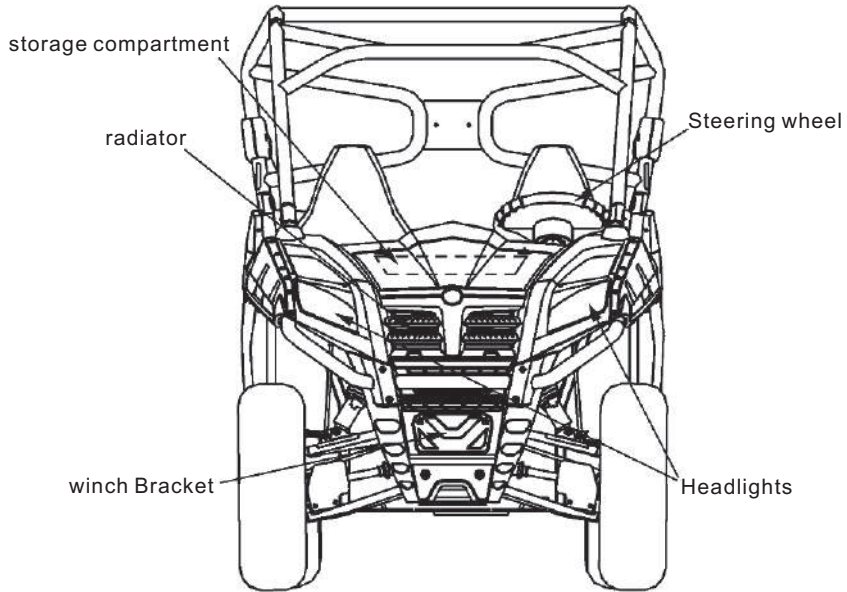

FEATURES AND CONTROLS

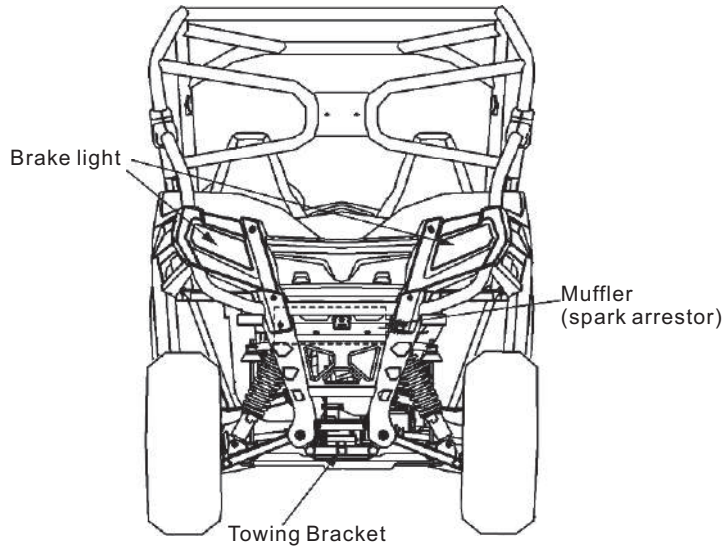

TRAILER RECEIVER HITCH BRACKET

This vehicle is equipped with a receiver hitch bracket for a trailer hitch.

Trailer towing equipment is not supplied with this vehicle.

To avoid injury and possible damage, always heed the warnings and towing capacities outlined on pages 85.

FEATURES AND CONTROLS

REAR SERVICE PANEL

The rear service panel is located behind the seats on the frame of the vehicle. Remove the seats to access the service panel. Remove the service panel to access serviceable engine components and clutches.

SEATS

Before operating the vehicle, always push down on both seat backs to ensure the latches are secure.

Seat Adjustments

Loosen (do not remove) the four screws located on the seat bottom. Slide the seat forward or rearward to the desired position. Tighten the four screws, Torque :(8 Nm). Do not over tighten.

Seat Removal

1. Pull up on the seat latch lever located under the rear edge of the seat.
2. Tilt the seat forward.
3. Lift the seat upward to remove it from the vehicle.

Reverse this procedure to reinstall the seat. Make sure the front edge of the seat is properly installed to the seat retainer bar.

Press down firmly at the rear of the seat to engage the rear latch.

FEATURES AND CONTROLS

STEERING WHEEL

The steering wheel can be tilted upward or downward for rider preference. Lift and hold the steering wheel adjustment lever while moving the steering wheel upward or downward. Release the lever when the steering wheel is at the desired position.

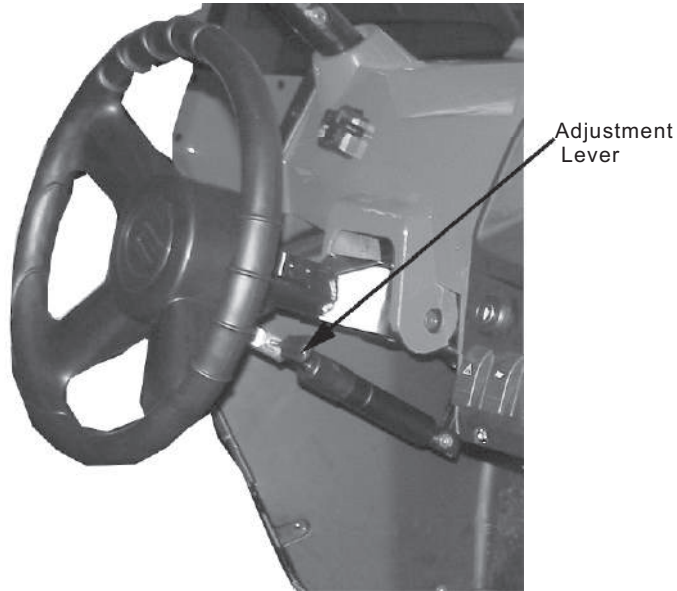

FEATURES AND CONTROLS

FRONT TRUNK

Remove the front panel and check the front trunk.

The cubage of front trunk is 13L.

FRONT PANEL

1. Front trunk, radiator, and secondary water tank under the front panel.
2. Front panel needs to be removed for inspections.
3. Knob on the front panel, unscrew knob to remove the panel
4. Pull out the front panel by holding at the of the top panel
5. Remove the left panel.

FUEL CAP

Fuel cap is near the seat of passenger.

Refuel with 93 Octane or above.

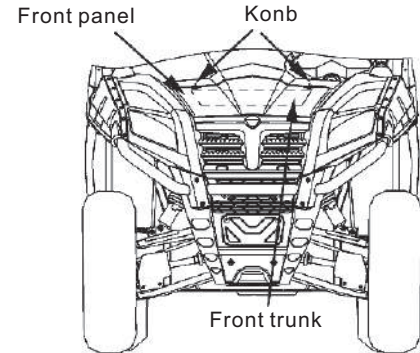
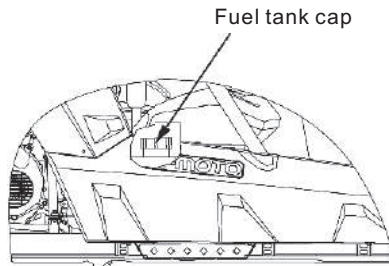

FEATURES AND CONTROLS

SEAT BELTS

This vehicle is equipped with three-point lap and diagonal seat belts for the operator and passenger.

⚠WARNING

Riding in this vehicle without wearing the seat belt can result in serious injury or death, in the event of an accident or sudden stop. Always make sure the seat belts are secured for both the operator and passenger before riding.

To wear the seat belt properly, follow this procedure:

1. Pull the seat belt latch downward and across your chest, toward the buckle at the inner edge of the seat. The belt should fit snugly across your hips and diagonally across your chest. Make sure the belt is not twisted.
2. Push the latch plate into the buckle until it clicks.
3. Release the strap, it will self tighten.

⚠NOTE

Press the red release latch on the buckle to release the seat belt.

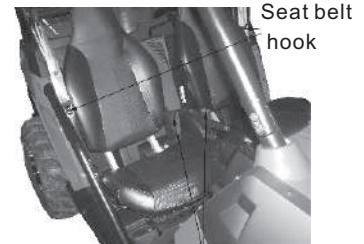

Seat belt hook

FEATURES AND CONTROLS

Inspect all seat belts for proper operation before each use of the vehicle.

1. Push the latch plate into the buckle until it clicks. The latch plate must slide smoothly into the buckle. A click indicates that it's securely latched.
2. Push the red release latch in the middle of the buckle to make sure it releases freely.
3. Pull each seat belt completely out and inspect the full length for any damage, including cuts, wear, fraying, dirt, debris, or stiffness. If any damage is found, have the seat belt system checked and/or replaced by an authorized CFMOTO dealer.

SWITCHES

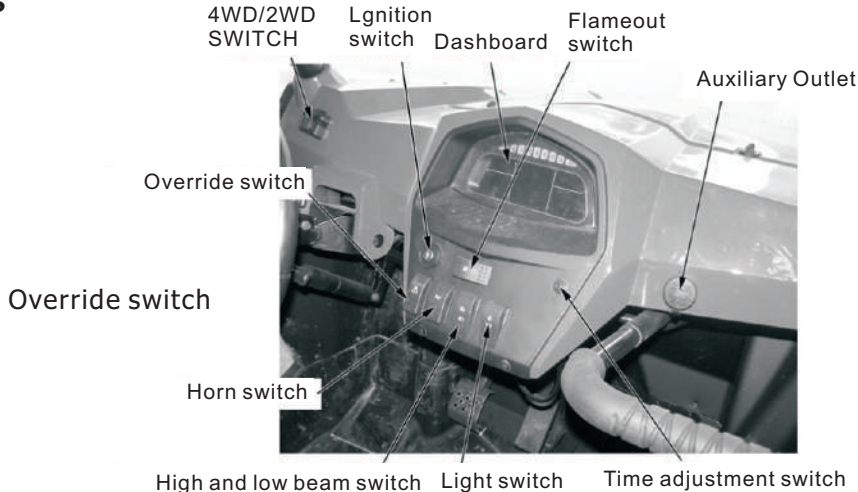

FEATURES AND CONTROLS

TIME ADJUSTMENT SWITCH

Near the dashboard, used for adjusting the hour and minutes by operating the time adjustment switch. Hour by shortly pressed to adjust. Minute by long pressed to adjust.

⚠WARNING

IGNITION SWITCH



Leaving the keys in the ignition can lead to unauthorized use of the vehicle resulting in serious injury or death. Always remove the ignition key when the vehicle is not in use.

The ignition switch is a three-position, key-operated switch. Use the ignition switch to start the engine. See page 68 for starting procedures. The key can be removed from the switch when it is in the OFF position.

OFF	The engine is off. Electrical circuits are off, except accessory as winch motor.
ON	Electrical circuits are on. Electrical equipment can be used.
START	Turn the key to the START position to engage the electric starter. The key returns to the ON position when released.

FEATURES AND CONTROLS

LIGHT SWITCH INDICATORS

Light switch including: “”, “”, “”

 light switch in this position,headlight,and instrument light,front and rear sidelights lighted.

 light switch in this position,instrument light,front, and rear sidelights illuminated.

● light switch in this position all lights are off.

 High Beam light is on when the dash indicator is illuminated.

 Low Beam light is on when the dash indicator is illuminated.

HORN SWITCH

Press the horn switch, the horn will sound.

AWD SWITCH

Speed is limited based on AWD. If you need to more power when attempting to overtake another vehicle, release the speed limited by pressing the AWD switch Resume the speed limited function by loosening the AWD switch. AWD indicator light is illuminated when the switch is pressed.

FEATURES AND CONTROLS

FLAME OUT SWITCH

Press this button to stop the engine ☒

Press this button to restart the engine ↻

AUXILIARY OUTLET

Auxiliary outlet voltage: 12V; Max outlet current: 10A

4WD SWITCH

2WD to 4WD, stop the vehicle, change the switch to 4WD.

When the switch is in 4WD, 4WD indicator light will be on ☐☐

When you want to shift from 4WD to 2WD stop the vehicle. Confirm the rocker switch (1) is in the position (a) press the switch to 2WD.

4WD AND 4WD LOCK SWITCH

“LOCK”/ “4WD” (1)

Lock the front wheel drive on 4WD , confirm 4WD switch in the “4WD”. Stop the vehicle, press the rocker(2) to (b), then if switch to the lock position. When locked the 4WD, 4WD-Lock .

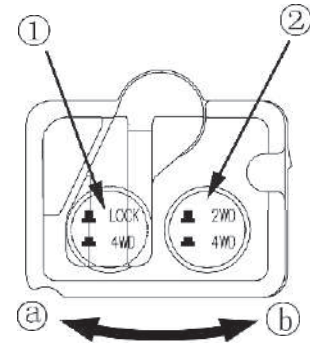

FEATURES AND CONTROLS

indicator light will be on  Open the 4WD-Lock switch, stop the vehicle, and change the switch to “4WD”.

NOTE

When the switch on “LOCK”, indicator light is twinkle until locked 4WD.

When the 4WD-Lock indicator light twinkle , turn left or right for steering wheel, it is better to front wheel for 4WD Locked.

Confirm whether it is in 4WD-Lock(indicator light is blinking) and the engine is not speed.

When the vehicle is in 4WD-LOCK, speed is limited under 35 Km/h(22mph) if you need full power of the engine release the 4WD lock switch.

FEATURES AND CONTROLS

AUTOMATIC TRANSMISSION GEAR SELECTOR

The transmission gear selector (1) is located on the left side of the vehicle.

- L: Low Gear
- H: High Gear
- N: Neutral
- R: Reverse
- P: Parking

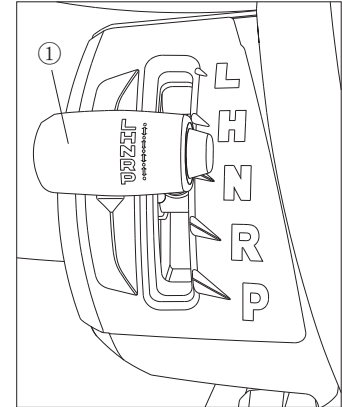

To shift from N to H or R, from L to H, from P to R, depress the button of gear selector. To shift from H to L or N, from R to N or P, it is not necessary to depress this button.

When shifting among N, R, P, you must push the brake pedal.

FEATURES AND CONTROLS

⚠ CAUTION

Shifting gears with the engine speed above idle or while the vehicle is moving could cause transmission damage. To change gears, stop the vehicle, and with the engine idling, move the lever to the desired gear. Push the brake pedal before attempting to shift into reverse or park. Whenever the UTV is left unattended, always place the transmission in the park position. Maintaining shift linkage adjustment is important to assure proper transmission function. See your dealer if you experience any shifting problems.

USING LOW RANGE AND HIGH RANGE:

CONDITION	RANGE TO USE
Operating at speeds less than 7 MPH (11 km/h)	LOW
Operating on rough terrain or over obstacles	LOW
Loading the vehicle onto a trailer	LOW
Towing heavy loads	LOW
Operating at speeds greater than 7 MPH (11 km/h)	HIGH

FEATURES AND CONTROLS

BRAKE PEDAL

Depress the brake pedal to slow or stop the vehicle. Apply the brakes while starting the engine. Check if it feels soft before driving, inspect the brake fluid insure it is between the FULL and LOW limits or if brake fluid is leaking.

THROTTLE PEDAL

Push the pedal down to increase engine speed. Spring pressure returns the pedal to the rest position when released. Always check that the throttle pedal returns normally before starting the engine. Make sure there's adequate throttle pedal free play. (See page 112) for throttle pedal adjustment procedures.

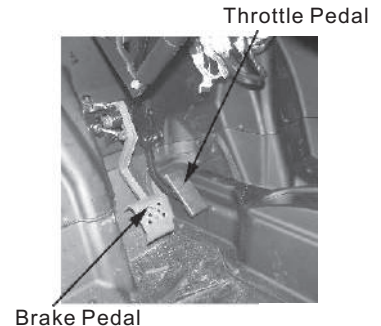

FEATURES AND CONTROLS

INSTRUMENT CLUSTER

COOLING LIQUID TEMPERATURE INDICATOR(1)

If the temperature indicator pointer is in the white Zone C: Temperature is normal.

If the temperature indicator pointer is in the Red Zone H: Stop the engine and let the temperature drop down.

If the temperature frequently overheats inspect the coolant level or check with your dealer.

⚠ CAUTION

If the UTV is overweight, engine could overheat. If this is the cause, reduce the load weight in the scope of mass load weight.

Perating the engine is an overheated condition can cause sever engine damage

SPEEDOMETER(2): Displays speed.

ODOMETER(3): Displays odometer.

FUEL GAUGE(4): Displays the surplus fuel. “F” FUEL TOTAL: 27L

When the pointer is in the red zone, it shows that the surplus fuel is only 4.01, and it needs to be refueled.

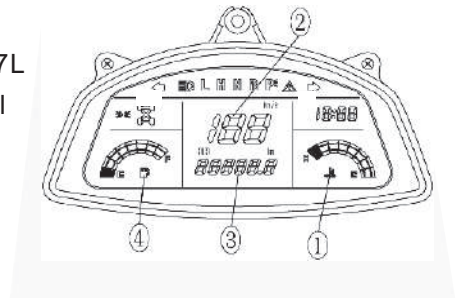

FEATURES AND CONTROLS

Switch 2WD/4WD is in the 4WD position indicator will be illuminated ☐☐

Switch LOCK is in the LOCK-4WD position will be illuminated ✕

4WD indicator will be ON after vehicle has been moved due to the mechanical synchronous sets in the front wheel drive, case.

- LOW GEAR INDICATOR LIGHT (L) (2).
- HIGH GEAR INDICATOR LIGHT (H) (3).
- NEUTRAL INDICATOR LIGHT (N) (4)
- REVERSE INDICATOR LIGHT (R) (5)

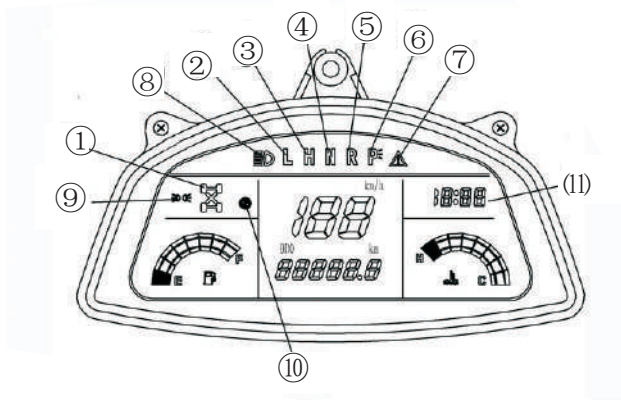

FEATURES AND CONTROLS

PARKING INDICATOR LIGHT “P” (6)
AWD INDICATOR LIGHT (7)
HIGH BEAM INDICATOR LIGHT (8)
LIGHT POSITION SWITCH INDICATOR (9)
MALFUNCTION INDICATOR LAMP (10)
CLOCK (11)

If the instrument clusters fails to illuminate or operate in any fashion check with your dealer for repairs.

OPERATION

BREAK-IN PERIOD

The break- in period for your new UTV is very important, it is not only a simple action for you, which is as important as a proper break- in stated in manual. Careful treatment of a new engine will result in more efficient performance and longer life for the engine. Perform the following procedures carefully.

⚠ CAUTION

Do not load or tow cargo during the first 20 hours of use, do not operate at full throttle. It may damage engine parts or decrease engine life if excessively increase throttle during the first 20 hours of use.

Do not run engine with throttle over 1/2 open during the first 10 hours of use. Do not run engine with throttle over 3/4 open during the first 10 to 20 hours of use.

Operate this UTV in normal condition after break- in period.

Use of any oils other than those recommended may cause serious engine damage. we recommend the use of special oil for 4-stroke engine: SAE 15W-40/SG.

Perform the following procedures before operation:

1. Fill the fuel tank with gasoline.
2. Put UTV on a level surface to check the oil level. Add recommended oil if necessary to maintain the oil level between the minimum and maximum level marks of the dipsticks.
3. Drive slowly at first. Select an open area that allows room to familiarize yourself with vehicle operation and handling.
4. Vary throttle positions. Do not operate at sustained idle.

OPERATION

5. Perform regular checks on fluid levels, controls, and areas outlined on the daily pre-ride inspection checklist. See page 66.
6. Pull only light loads.
7. During the break-in period, change both the oil and oil filter at 20 hours or 750km.

BRAKE SYSTEM BREAK-IN:

Apply only moderate braking force for the first 50 stops. Aggressive or overly forceful braking when the brake system is new could damage brake pads and rotors.

CVT BREAK-IN (CLUTCHES/BELT):

A proper break-in, of the clutches and drive belt will ensure a longer life and better performance. Break-in the clutches and belt by operating at slower speeds during the break-in period as recommended.

Pull only light loads.

Avoid aggressive acceleration and high speed operation during the break-in period.

OPERATION

PRE-RIDE INSPECTION

If a proper inspection is not done before each use, severe injury, or death could result. Always inspect the vehicle before each use to ensure it is in proper operating condition.

PRE-RIDE CHECKLIST		
ITEM	REMARKS	SEE PAGE
Brake system/lever travel	Ensure proper operation	114-116
Brake fluid	Ensure proper level	115
Front suspension Inspect	Lubricate if necessary	117
Rear suspension Inspect	Lubricate if necessary	117
Steering	Ensure free operation	
Tires	Inspect and check pressure	120
Wheels and fasteners	Ensure tightness	122

OPERATION

PRE-RIDE CHECKLIST		
ITEM	REMARKS	SEE PAGE
Frame nuts, bolts, fasteners	Inspect, ensure fastener tightness	
Fuel and oil	Ensure proper levels	95
Coolant level	Ensure proper levels	106
Coolant hoses	Inspect for leaks	
Throttle	Ensure proper operation	112
Gear shifting	Ensure proper operation	
Indicator lights/ switches	Ensure proper operation	63
Air filter	Inspect, clean	110
Air box sediment tube	Drain deposits whenever visible	
Headlamp	Check operation	123
Brake light/ tail lamp	Check operation	125
Riding gear	Wear helmet, gloves, protective clothing	43

OPERATION

STARTING THE ENGINE

Engine exhaust contains poisonous carbon monoxide and can cause loss of consciousness resulting in severe injury or death.

Never run an engine in an enclosed area.

1. Sit in the driver's seat and fasten the seat belt.
2. Place the transmission in PARK.
3. Apply the brakes.

⚠ NOTE Do not press the throttle pedal while starting the engine.

4. Turn the ignition key past the ON/RUN position to START.
5. Engage the starter for a maximum of five seconds. Release the key when the engine starts.
6. If the engine does not start within five seconds, return the ignition switch to the OFF position and wait five seconds. Repeat steps 4 and 5 until the engine starts.
7. Vary the engine RPM slightly with the throttle to aid in warm up until the engine idles smoothly.

STOPPING THE ENGINE

⚠ WARNING

Operating the vehicle immediately after starting could cause engine damage. Allow the engine to warm up for several minutes before operating the vehicle.

1. Release the throttle pedal completely and brake to a complete stop.
2. Place the transmission in PARK.
3. Turn the engine off.

OPERATION

⚠️WARNING

A rolling vehicle can cause property damage and serious injury. Always place the transmission in PARK when stopping the engine.

BRAKING

1. Release the throttle pedal completely.
2. Press on the brake pedal evenly and firmly.

Practice starting and stopping (using the brakes) until you're familiar with the controls.

⚠️NOTE

When the throttle pedal is released completely and engine speed slows to near idle, the vehicle has no engine braking.

⚠️WARNING

Failure to allow for increased braking distance when hauling cargo or towing a trailer may result in accident and injury. Always slow down and allow additional braking distance when towing or hauling cargo.

PARKING THE VEHICLE

⚠️WARNING

Gasoline is extremely flammable and can be explosive under certain conditions. When parking inside a garage or other structure, be sure that the structure is well ventilated and that the vehicle is not close to any source of flame or sparks, including any appliance with pilot lights.

OPERATION

⚠WARNING

A rolling vehicle can cause property damage and serious injury. Always place the transmission in PARK when stopping the engine.

1. Stop the vehicle on a level surface. Place the transmission in PARK.
2. Turn the engine off.
3. Remove the ignition switch key to prevent unauthorized use.

OPERATION

DRIVING YOUR UTV

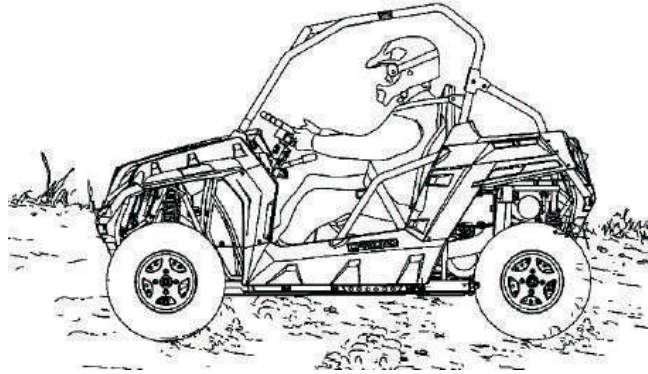

▲WARNING

Operating improperly can cause an accident or overturn which could result in severe injury or death. This vehicle handles differently than cars, trucks or other off-road vehicles. Operators of this vehicle must become familiar with vehicle handling at slow speeds before operating at faster speeds.

1. Do not carry a passenger until you have had at least two hours of driving experience with this vehicle.
2. Do not tow or carry cargo during this period.

OPERATION

3. Select an open area that allows room to familiarize yourself with the vehicle operation and handling.
4. Check your surroundings and determine your path of travel.
5. Keeping both hands on the steering wheel, slowly release the brakes and depress the throttle with your right foot to begin driving.
6. Do not carry a passenger until you have had at least two hours of driving experience with this vehicle.
7. Do not tow or carry cargo during this period.
8. Select an open area that allows room to familiarize yourself with the vehicle operation and handling.
9. Check your surroundings and determine your path of travel.
10. Keeping both hands on the steering wheel, slowly release the brakes and depress the throttle with your right foot to begin driving.
11. Drive slowly at first. On level surfaces, practice starting, stopping, turning, maneuvering, using the throttle, brakes, and driving in reverse. Learn how the vehicle handles when making both left and right turns at a slow speed.
12. Increase speed only after mastering all maneuvers at a slow speed.
13. After you become skilled at making turns and begin to operate at faster speeds, follow these precautions:
 - **Avoid sharp turns.**
 - **Never turn while applying heavy throttle.**
 - **Never make abrupt steering maneuvers.**
 - **Operate at speeds appropriate for your skills, the conditions and the terrain.**
 - **Do NOT do power slides, "donuts", jumps or other driving stunts.**

OPERATION

DRIVING WITH A PASSENGER



OPERATION

Complete the New Operator Driving Procedures outlined on pages 71-73.

Perform the pre-ride inspection. See page 66.

1. Make sure the passenger is at least 12 years of age and is tall enough to comfortably and safely sit in the passenger seat with the seat belt secured, put both feet on the floor and grasp the hand holds.
2. Make sure the passenger is wearing appropriate riding gear, including an approved helmet and eye protection.
4. Allow a passenger to ride only in the passenger seat.
5. Do not carry more than one passenger. Additional passengers can affect the operator's ability to steer and operate the controls.
6. Slow down. Always travel at a speed appropriate for your skills, and operating conditions. Avoid unexpected or aggressive maneuvers that could cause discomfort or injury to a passenger.
7. Vehicle handling may change with a passenger and/or cargo on board. Allow more time and distance for braking.
8. Always follow all operating guidelines as outlined on safety labels in this manual.

DRIVING ON SLIPPERY SURFACES

When driving on slippery surfaces such as wet trails.

OPERATION

loose gravel, or ice, be alert for the possibility of skidding and sliding. Under these conditions, follow these precautions:

1. Slow down when entering slippery areas.
2. Maintain a high level of alertness, reading the trail, and avoiding quick, sharp, turns which can cause skids.
3. Engage all-wheel drive, before wheels begin to lose traction.
4. Correct a skid by turning the steering wheel in the direction of the skid.

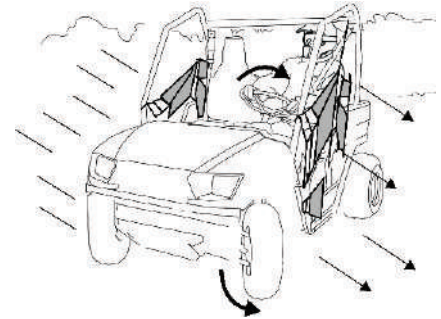

⚠WARNING

Severe damage to the drive train may occur if the AWD is engaged, while the wheels are spinning. Always allow the wheels to stop spinning before engaging AWD.

⚠WARNING

Failure to exercise care when operating on slippery surfaces can result in loss of tire traction, and cause loss of control, accident, and serious injury or death.

Never apply the brakes during a skid.

Do not operate on excessively slippery surfaces.

Always reduce speed and use additional caution when operating on slippery surfaces.

OPERATION

DRIVING UPHILL

Whenever traveling uphill, follow these precautions:

1. Drive straight uphill.
2. Proceed at a steady rate of speed and throttle opening.
3. Avoid unnecessary changes in speed or direction.
4. Avoid steep hills(15° maximum).

▲NOTE If ascending a steeper grade is unavoidable, engage all-wheel drive before ascending.

5. If the vehicle stalls while climbing a hill, apply the brakes. Place the transmission in reverse and slowly allow the vehicle to roll straight downhill while applying light brake pressure to control speed.

▲WARNING

Climbing hills improperly can cause loss of control or vehicle overturn. Always check the terrain carefully, before climbing a hill.

Braking and handling are greatly affected when operating in hilly terrain. Improper operating procedures, could cause loss of control or overturn, and result in serious injury or death. Avoid climbing steep hills (15° maximum).

Use extreme caution when operating on hills, and follow proper operating procedures outlined in the owner's manual.

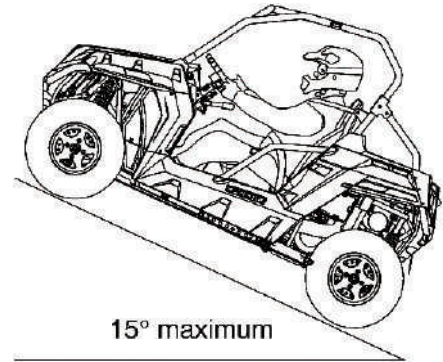

OPERATION

Never climb hills with excessively slippery or loose surfaces.

Never open the throttle suddenly.

Never go over the crest of a hill at high speed. An obstacle, a sharp drop, or another vehicle or person could be on the other side of the hill.

DRIVING ON A SIDEHILL(SIDEHILLING)

Avoid driving across the side of a hill. Control becomes difficult and there is an increased chance of vehicle overturn when driving on a hillside.

If crossing a hill is unavoidable, follow these precautions:

1. Engage all-wheel drive
2. Drive slowly and use extreme caution.
3. If the vehicle begins to overturn, or if it feels as if it may overturn, immediately turn downhill.
4. Avoid obstacles and changes in terrain that may lower or raise one side of the vehicle or cause the vehicle to slide.
5. If the vehicle begins to slide downhill, immediately turn downhill to stop the slide, or stop the vehicle and maneuver slowly and carefully until the vehicle can be driven straight downhill.

OPERATION

⚠️WARNING

Crossing hillsides or turning on hills can result in loss of control or vehicle overturn, resulting in severe injury or death. Avoid crossing the side of a hill. Avoid operating on steep hills (15° maximum).

DRIVING DOWNHILL

Whenever descending a hill, follow these precautions:

1. Slow down.
2. Always descend a hill with the transmission in forward gear. Never descend a hill with the transmission in neutral.
3. Travel straight downhill.
4. Apply the brakes lightly to aid in slowing.

⚠️WARNING

Traveling downhill improperly could cause loss of control or vehicle overturn.

Always check the terrain carefully before descending a hill.

Never descend a hill at high speed. Excessive speed may result in loss of vehicle control and lead to serious injury or death. Always operate slowly when traveling downhill.

Avoid descending a hill at an angle, which would cause the vehicle to lean sharply to one side. Travel straight downhill.

OPERATION

DRIVING IN DEEP WATER

⚠️WARNING

The large tires on your vehicle may cause the vehicle to float in deep or fast flowing water, which could result in loss of control and lead to serious injury or death. Never cross deep or fast-flowing water with your vehicle.

Your vehicle can operate through water with a maximum recommended depth equal to floor level.

Follow these procedures when operating through water:

1. Determine water depth and current before crossing
2. Never operate in water that exceeds the maximum recommended depth.
3. Choose a crossing where both banks have gradual inclines.
4. Proceed slowly, avoiding rocks and obstacles.
5. Wet brakes may have reduced stopping ability.
6. To dry out the pads, apply the brakes lightly several times while driving slowly.

⚠️NOTE

After running your vehicle in water, it's critical that you perform the services outlined in the Periodic Maintenance Chart beginning on page 89. Give special attention to engine oil, transmission oil, demand drive fluid, rear gear case oil, and all grease fittings.

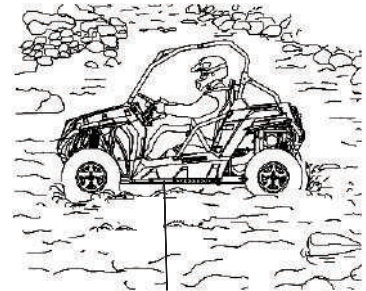

Level of footrest board

OPERATION

Immersion can result in major damage, if the vehicle isn't serviced correctly and promptly. After immersion, always take the vehicle to your dealer for service. Do not start the engine. If it's impossible to bring the vehicle to your dealer before starting the engine, perform the service outlined on page 125, and take the vehicle to the dealership.

DRIVING OVER OBSTACLES

1. Be alert! Look ahead, and learn to read the terrain you're traveling on. Watch for hazards such as logs, rocks, and low hanging branches
2. Before operating in a new area, check for obstacles.
3. Avoid operating over large obstacles, such as rocks, and fallen trees. If unavoidable, use extreme caution and operate slowly.
4. Always have a passenger dismount and move away from the vehicle, before operating over an obstacle that could cause an overturn.

⚠️ WARNING

Severe injury or death can result if your vehicle suddenly meets a hidden obstacle. Not all obstacles are immediately visible. Reduce speed and travel with caution in unfamiliar terrain.

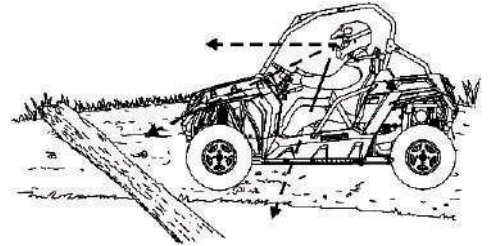

OPERATION

DRIVING IN REVERSE

Follow these guidelines when operating in reverse.

1. Always check for obstacles or people behind vehicle.
2. Apply the throttle lightly; never open the throttle suddenly.
3. Back up slowly.
4. Apply the brakes lightly for stopping.
5. Avoid making sharp turns.

⚠️WARNING

Failure to use caution when operating in reverse can result in serious injury or death. Before shifting into reverse, always check for obstacles or people behind the vehicle. When it's safe to proceed, back up slowly. Avoid making sharp turns.



OPERATION

PARKING ON AN INCLINE

Avoid parking on an incline if possible. If it's unavoidable, follow these precautions.

1. Place the transmission in PARK.
2. Turn off the engine.
3. Block the rear wheels on the downhill side.

⚠WARNING

A rolling vehicle can cause property damage and serious injury. Always place the transmission in PARK, when stopping the engine. Always block the downhill side of the wheels, if leaving the vehicle on a hill, or park the vehicle in a sidehill position instead.

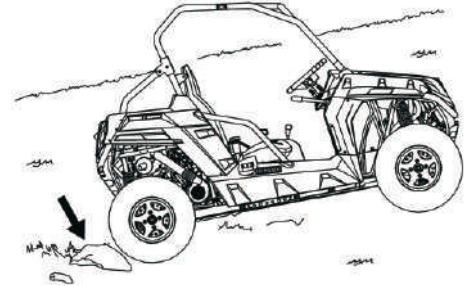

OPERATION

⚠WARNING

Overloading the vehicle, carrying or towing cargo improperly can alter vehicle handling and may cause loss of control or brake instability. Always follow these precautions when hauling cargo: Never exceed the stated load capacity for this vehicle.

REDUCE SPEED AND ALLOW GREATER DISTANCES FOR BRAKING WHEN HAULING CARGO. When operating over rough or hilly terrain, reduce speed and cargo to maintain stable driving conditions. Always operate the vehicle with extreme care when hauling or towing loads. Slow down and drive in the lowest gear available.

OPERATE ONLY WITH STABLE AND SAFELY ARRANGED LOADS. When handling off-centered loads that cannot be centered, securely fasten the load and operate with extra caution. Always attach the tow load to the hitch point designated for your vehicle.

HEAVY LOADS CAN CAUSE BRAKING AND CONTROL PROBLEMS. Use extreme caution when applying brakes with a loaded vehicle. Avoid terrain or situations that may require backing downhill. **USE EXTREME CAUTION** When operating with loads that extend over the rack sides. Stability and maneuverability may be adversely affected, causing the vehicle to overturn

DO NOT TRAVEL FASTER THAN THE RECOMMENDED SPEEDS. Vehicle should never exceed 10 mph (16kph) while towing a load on a level grass surface. Vehicle speed should never exceed 5 mph (8 kph); when towing loads on rough terrain; while cornering; or while ascending or descending a hill.

OPERATION

Driving with passengers in the cargo box can result in severe injury or death. Never allow a passenger to ride in the cargo box. A passenger must always ride in the passenger seat, with the seat belt fastened securely.



HAULING CARGO

Your CFMOTO vehicle has been designed to carry or tow specific capacities. Reduce speed and allow a greater distance for braking when carrying cargo. Loads should be centered and carried as low as possible in the box. For stability on rough or hilly terrain, reduce both speed and cargo. Exercise caution if the cargo load extends over the side of the box. Always read and understand the load distribution warnings listed on warning labels and in this manual. Never exceed the maximum capacities specified for your vehicle.

OPERATION

BELT LIFE

To extend belt life, use low gear when hauling or towing heavy cargo.

TOWING LOADS

Towing improperly can alter vehicle handling and may cause loss of control or brake instability, which can result in serious injury or death. Always follow these precautions when towing:

1. Never load more than 110 lbs. (50kg) tongue weight on the towing bracket.
2. Do not operate the vehicle too fast when towing. Towing a trailer increases braking distance. Do not tow more than the recommended weight for the vehicle.
3. Attach a trailer to the trailer hitch bracket only. Do not attach a trailer to any other location, which could result in loss of control of the vehicle.

MODEL	PULLING LOAD (TRAILER PLUS CARGO)	TONGUE WEIGHT (VERTICAL WEIGHT ON TRAILER HITCH POINT)
CF600-3(Z6)	275.3 lbs(125kg)	110 lbs(50kg)
CF600-6(Z6 EX)	275.3 lbs(125kg)	110 lbs(50kg)

EMISSION CONTROL SYSTEMS

NOISE EMISSION CONTROL SYSTEM

Do not modify the engine, intake or exhaust components, as doing so may affect compliance with U.S.A. EPA noise control requirements (40 CFR 205) and local noise level requirements.

OPERATION ON PUBLIC LANDS IN THE U.S.A.

Your vehicle has a spark arrestor that was tested and qualified to be in accordance with the USDA Forest Service Standard 5100-1C.

Federal law requires that this spark arrestor be installed and functional when the vehicle is operated on public lands.

Operation of off-road vehicles on public lands in the U.S.A. is regulated by 43 CFR 8343. Violations are subject to monetary penalties. Federal regulations can be viewed online at www.gpoaccess.gov/ecfr/.

CRANKCASE EMISSION CONTROL SYSTEM

This engine is equipped with a closed crankcase system.

Blow-by gases are forced back to the combustion chamber by the intake system. All exhaust gases exit through the exhaust system.

EXHAUST EMISSION CONTROL SYSTEM

Exhaust emissions are controlled by engine design. An electronic fuel injection (EFI) system controls fuel delivery. The engine and EFI components are set at the factory for optimal performance and are not adjustable. The emissions label is located on the lower frame behind the driver's seat.

ELECTROMAGNETIC INTERFERENCE

This spark ignition system complies with Canadian ICES-002. This vehicle complies with European directives 97/24/EC and 89/336/EEC.

MAINTENANCE & LUBRICATION

PERIODIC MAINTENANCE CHART

Careful periodic maintenance will help keep your vehicle in the safest, most reliable condition. Inspection, adjustment, and lubrication of important components are explained in the periodic maintenance chart.

Inspect, clean, lubricate, adjust, and replace parts as necessary. When inspection reveals the need for replacement parts, please use genuine parts available from your dealer.

NOTE

Service and adjustments are critical. If you are not familiar with safe service and adjustment procedures, have a qualified dealer perform these operations. Maintenance intervals in the following chart are based upon average riding conditions and an average vehicle speed of approximately 10 miles or 20 Km per hour. Vehicles subjected to severe use must be inspected and serviced more frequently.

MAINTENANCE & LUBRICATION

SEVERE USE DEFINITION

- Frequent immersion in mud, water, or sand.
- Racing or race-style high RPM use.
- Prolonged low speed, heavy load operation.
- Extended idle.
- Short trip cold weather operation.

Pay special attention to the oil level. A rise in oil level during cold weather can indicate contaminants collecting, in the oil sump or crankcase. Change oil immediately if the oil level begins to rise. Monitor the oil level, and if it continues to rise, discontinue the use, and determine the cause or see your dealer.

KEY POINTS OF MAINTENANCE CHART

- ▶ Perform these procedures more often for vehicles subjected to severe use.
- Have an authorized dealer perform these services.

DANGER

Improperly performing the procedures marked with a “■” could result in component failure and lead to serious injury or death. Have an authorized dealer perform these services.

MAINTENANCE & LUBRICATION

ITEM	Maintenance Interval (whichever comes first)			REMARKS
	HOURS	CALENDAR	MILES (km)	
■ Steering	—	Pre-Ride	—	Make adjustments as needed. See Pre-Ride Checklist on page 66
▶ Front Suspension	—	Pre-Ride	—	
▶ Rear Suspension	—	Pre-Ride	—	
Tires	—	Pre-Ride	—	
▶ Brake Fluid	—	Pre-Ride	—	
▶ Brake Level and Lever Travel	—	Pre-Ride	—	
Brake System	—	Pre-Ride	—	
Wheels/Fasteners	—	Pre-Ride	—	
Frame Fasteners	—	Pre-Ride	—	
▶ Engine Oil level	—	Pre-Ride	—	
▶ Air Inlet, Air Filter	—		—	Inspect and clean if necessary
▶ Air box Sediment tuber	—		—	Drain Deposit when visible
Coolant	50H	Daily	1500	Check level daily/Change coolant Every 2 years or 6000km/200H, but initial check Should be done after 20H or 750km.
Headlight /Tail light	—	Daily	—	Check operation; apply dielectric grease if replacing.

MAINTENANCE & LUBRICATION

ITEM		Maintenance Interval whichever comes first			REMARKS
		Hours	Calendar	Miles (km)	
	Air filter, element	50H		1500	Inspect every 1000km or 100 hours. initial cleaning or replacement should be done after 750km or 20H.
	CVT outlet pipe		Weekly		Drain water as needed, check often if operating in wet conditions.
	Brake pad wear	10H	Monthly	100	Inspect periodically
	Battery	20H	Monthly	200	Check terminals; clean; test
▶	Front gear case oil	25H	Monthly	250	Inspect level; change yearly
▶	Rear gear case oil	25H	Monthly	250	Inspect level; change yearly
▶	Transmission oil	25H	Monthly	250	Inspect level; change yearly
▶	Engine oil change (Break-in)	20H		250	Change
▶	General lubrication	50H	3M	500	Lubricate all fittings, pivots, cables, etc.
	Steering knuckle	50H	6M	500	Lubricate
■	Steering handlebar	50H	6M	500	Lubricate
▶	Front suspension	50H	6M	500	Lubricate

MAINTENANCE & LUBRICATION

ITEM		Maintenance Interval whichever comes first			REMARKS
		ours	Calendar	Miles (km)	
	Rear suspension	50H	6M	500	lubricate
	Gearshift	28H	1M	500	Inspect, lubricate, adjust
■	Throttle cable/Switch	50H	6M	500	Inspect, adjust; lubricate; replace if necessary
	Drive belt	50H	6M	1500	Inspect; adjust; replace if necessary. Replace for every 3000km
	Cooling system	50H	6M	500	Inspect coolant strength seasonally; pressure test system yearly
▶	Engine oil change	100H	12M	3000	Perform a break-in oil change at 25 hours/750km
▶	Fuel hose	100H	12M	1000	Inspect routing, condition, Replace highpressure fuel hose every 4 years.
■	Valve clearance	100H	12M	3000	Inspect, Adjust, Initial: 750km or 20H
■	Fuel system	100H	12M	1000	Inspect cap of fuel tank, fuel pump and fuel relay
■	Oil filter	100H	12M	3000	Initial change: 750km or 20H
▶	Radiator	200H	24M	3000	Inspect; clean external surfaces
▶	Cooling hoses	100H	12M	1000	Inspect; Initial: 300km or 10H

MAINTENANCE & LUBRICATION

ITEM	Maintenance Interval (whichever comes first)			REMARKS
	Hours	Calendar	Miles (km)	
Engine mounts	100H	12M	3000	Inspect. Initial: 300km or 10H
Exhaust pipe and muffler	100H	12M	1000	Inspect
Ignition coil	100H	12M	1000	Inspect and replace as needed
ECU	100H	12M	1000	Inspect and replace as needed
Wirings and cables	100H	12M	1000	Inspect for wear, routing, security; apply dielectric grease to connectors subjected to water, mud, etc.
Clutches(drive and driven pulley)	100H	12M	3000	Inspect; clean; replace worn parts
Wheel bearings	100H	12M	1600	Inspect and replace as necessary
Brake fluid	200H	24M	2000	Change every two years
Spark plug	100H	12M	3000	Initial: 750km or 20H. Replace every 6000km
Idle condition				Inspect every component. 1300±100r/min
Toe adjustment				Inspect periodically; adjust when parts are replaced
Auxiliary brake				Inspect daily; adjust as needed
Headlight aim				Adjust as needed

MAINTENANCE & LUBRICATION

RECOMMENDED LUBE

Check and lubricate all components at the intervals outlined in the Periodic Maintenance Chart beginning on page 89. Items not listed in the chart should be lubricated at the General Lubrication interval.

KEY POINTS OF LUBRICATION CHART

► More often under severe use, such as wet or dusty conditions

★ All Season Grease

- Use U-Joint Lube every 500 miles, before long periods of storage, or after pressure washing or submerging.

ITEM	LUBE	METHOD
Engine Oil	SAE15W/40 SG	Use dipstick to check oil level
Brake Fluid	DOT 3 or DOT4	Keep level between Upper and Lower line, see page 115
Front gear case oil	SAE15W/40 SG or SAE80W/90 GL-4	See page 101
Rear gear case oil	SAE15W/40 SG or SAE80W/90 GL-4	See page 101
Ball joint	Grease	

MAINTENANCE & LUBRICATION

LUBRICATION RECOMMENDATIONS

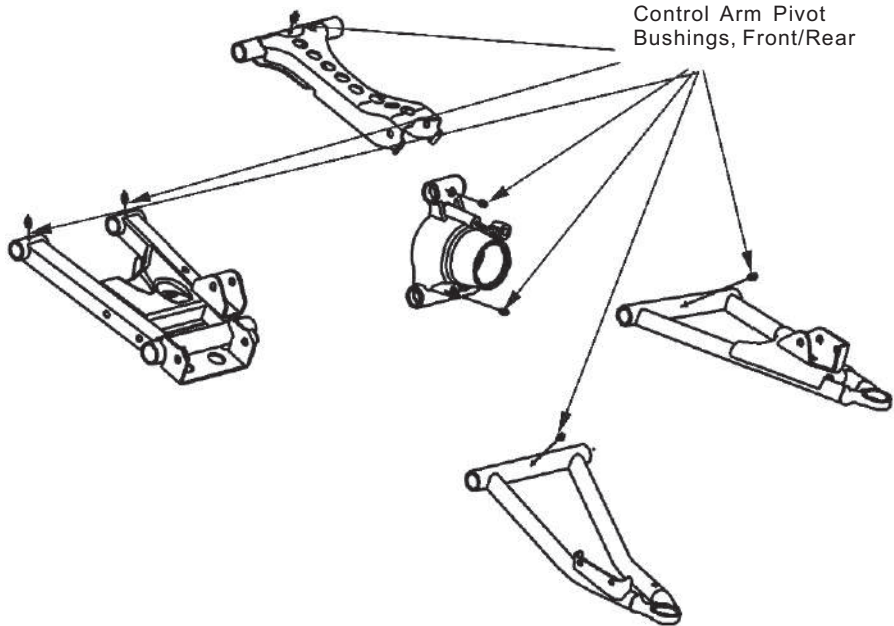

MAINTENANCE & LUBRICATION

ENGINE OIL

Always check and change engine oil at intervals outlined in the Periodic Maintenance Chart beginning on page 89. Always change the oil filter whenever changing oil.

SAE15W/40 SG Oil

We strongly recommend use of **SAE15W/40 SG Oil**, API certified “SG oil”. If **SAE15W/40 SG Oil** is unavailable, choose oil following the right instructions according to the engine ambient temperature.

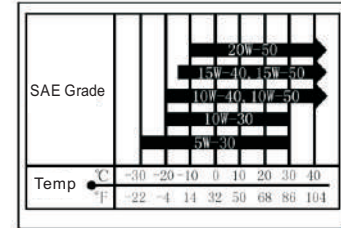

Oil may need to be changed more frequently if SAE15W/40 SG oil is not used. Follow the manufacture’s instructions for ambient temperature operation.

⚠ CAUTION

Mixing brands or using a non-recommended oil may cause serious damage to the engine. We recommend use of **SAE15W/40 SG Oil**, never use substitute or mix oil brands.

⚠ WARNING

Vehicle operation with insufficient, deteriorated, or contaminated engine oil will cause accelerated wear and may result in engine seizure, accident and injury. Always perform the maintenance procedure as outlined in the Periodic Maintenance Chart.

MAINTENANCE & LUBRICATION

ENGINE OIL

Always check and change engine oil at intervals outlined in the Periodic Maintenance Chart, beginning on page 89. Always change the oil filter whenever changing oil.

OIL CHECK

The oil dipstick and fill tube is located on the engine, behind the passenger seat.

1. Position the vehicle on a level surface.
2. Place the transmission in PARK. Apply the brakes.
3. Start the engine. Allow it to idle for 20-30 seconds. Stop the engine.
4. Remove both seats. Remove the rear service panel.
5. Remove the dipstick from the left side. Wipe it dry with a clean cloth.
6. Reinstall the dipstick completely, but do not lock it.

The dipstick must be inserted completely to keep the angle and depth of the stick consistent.

7. Reinstall the dipstick.
8. Seat the lever lock.

Dipstick



MAINTENANCE & LUBRICATION

ENGINE OIL AND FILTER CHANGE

⚠ CAUTION

Hot oil can cause serious skin burns. Do not allow hot oil to come into contact with skin. Always check and change engine oil at intervals outlined in the Periodic Maintenance Chart, beginning on page 89.

1. Always change the oil filter whenever changing oil.
2. The engine drain plug is located on the bottom of the crankcase.
3. Position the vehicle on a level surface.
4. Place the transmission in PARK. Apply the brakes.
5. Start the engine. Allow it to idle for 2-3 minutes. Stop the engine.
6. Clean the area around the drain plug.
7. Place a drain pan beneath engine crankcase and remove the drain plug.
8. Allow the oil to drain completely.
9. Reinstall the sealing washer on the drain plug.

⚠ NOTE

The sealing surface on drain plug and crankcase should be clean, and free of burrs, nicks or scratches.

10. Drain plug torque: 22ft.lbs (30Nm)

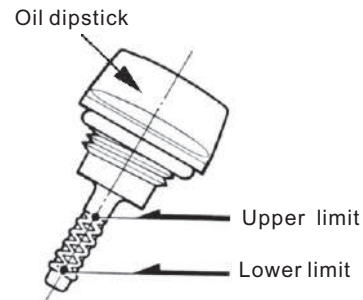

MAINTENANCE & LUBRICATION

OIL AND FILTER CHANGE(CONT.)

11. Using a cap-style oil filter wrench, turn the filter counter-clockwise to remove it.
12. Using a clean dry cloth, clean the filter, sealing surface on the crankcase.
13. Lubricate the o-ring on the new filter with a film of fresh engine oil. Check to make sure the o-ring is in good condition.
14. Install the new filter and turn by hand until the filter gasket contacts the sealing surface, then turn an additional 1/2 turns with special wrench.
15. Remove the dipstick and fill with 2.5L recommended oil.
16. Place the transmission in PARK. Apply the brakes
17. Start the engine. Allow it to idle for 2 minutes.
18. Stop the engine. Inspect for leaks.
19. Re-check the oil level on the dipstick and add oil as necessary to bring the level to the upper mark on the dipstick.
20. Dispose of used filter and oil properly.

GEAR CASES

DEMAND DRIVE UNIT (FRONT GEAR CASE)

Always check and change engine oil at intervals outlined in the Periodic Maintenance Chart beginning on page 89. Refer to the Gear Case Specifications Chart on page 101 for recommended lubricants, capacities, and torque specifications.

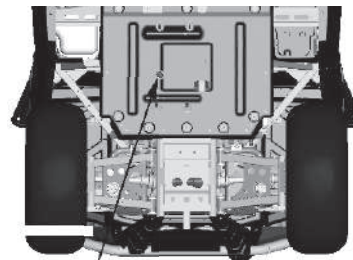

Engine oil Drain plug

MAINTENANCE & LUBRICATION

FLUID CHECK

The fill plug is located on the bottom right side of the demand drive unit. Maintain the fluid level even with the bottom thread of the fill plughole.

1. Position the vehicle on a level surface.
2. Remove the fill plug .Check the fluid level.
3. Add the recommended fluid as needed.
4. Reinstall the fill plug. Torque specifications.

FLUID CHANGE

The drain plug is located on the bottom of the gear case.

1. Remove the fill plug.
 2. Place a drain pan under the drain plug.
 3. Remove the drain plug. Allow the fluid to drain completely.
 4. Clean the drain plug.
 5. Reinstall the drain plug with new o-ring. Torque to specification.
 6. Add the recommended fluid. Maintain the fluid level even with the bottom thread of the fill plug hole.
 7. Reinstall the fill plug with new o-ring. Torque to specification.
 8. Check for leaks. Discard used fluid properly.
 9. Remove the dipstick and check the level.
- Maintain the oil level within the upper and lower limit.

DO NOT OVERFILL.

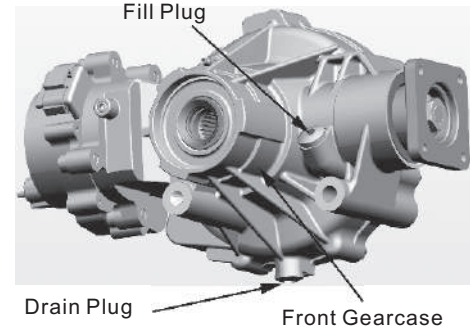

MAINTENANCE & LUBRICATION

REAR GEAR CASE

Always check and change engine oil at intervals outlined in the Periodic Maintenance Chart beginning on page 89. Refer to the Gearcase Specifications Chart on page 101 for recommended lubricants, capacities, and torque specifications.

FLUID CHECK

The fill plug is located on the right side of the rear gear case. Maintain fluid level even with the bottom thread of the fill plughole.

1. Position the vehicle on a level surface.
2. Remove the fill plug. Check the fluid level.
3. Add the recommended fluid as needed.
4. Reinstall the fill plug. Torque to specification.

FLUID CHANGE

The drain plug is located on the bottom right side of the rear gear case.

1. Remove the fill plug.
2. Place a drain pan under the drain plug. Remove drain plug.
3. Allow the fluid to drain completely.
4. Clean the drain plug. Torque to specification.
5. Add the recommended fluid. Maintain the fluid level even with the bottom thread of the fill plughole.
6. Reinstall the fill plug. Torque to specification.
7. Check for leaks. Discard used fluid properly.

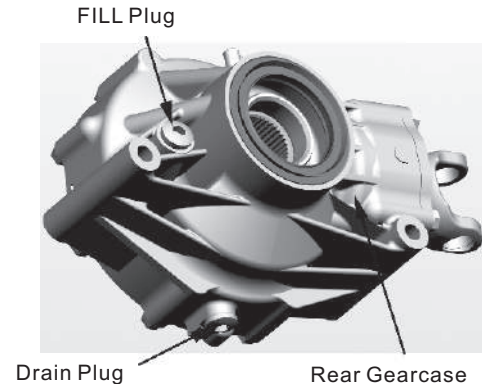

MAINTENANCE & LUBRICATION

GEARCASE SPECIFICATION CHART

Use of other fluids may result in improper operation of components.

Gearcase	Lubricant	Capacity	Fill Plug Torque	Drain Plug/Level Check Plug Torque
Transfer Case (196S-C)	SAE15W/40 SG	preliminary: 2800ml change: 2500ml		30 Nm
Demand Drive Unit (Front Gearcase)	SAE15W/40 SG or SAE80W/90 GL-4	330ml(preliminary), 280ml(change)	25Nm	25Nm
Rear Gearcase	SAE15W/40 SG or SAE80W/90 GL-4	300ml(preliminary), 250ml(change)	25Nm	25Nm

MAINTENANCE & LUBRICATION

SPARK PLUGS

⚠ CAUTION

Using non-recommended spark plugs can result in serious engine damage.

Always use CFMOTO-recommended spark plugs.

Refer to the specification sections beginning on page 149.

SPARK PLUG CAP/TORQUE

Model	Electrode Gap	New Plug Torque	Used Plug Torque
DPR7EA-9(NGK)	0.8-0.9mm	18Nm	18Nm

Spark plug condition is indicative of engine operation.

The spark plug firing end condition should be read after the engine is warmed-up and the vehicle is driven at higher speeds.

Immediately check the spark plug for correct color. See page 103.

⚠ WARNING

A hot exhaust system and engine can cause serious burns.

Wear protective gloves when removing a spark plug for inspection.

MAINTENANCE & LUBRICATION

SPARK PLUG CONDITION

NORMAL PLUG

The normal insulator tip is gray, tan, or light brown. There will be few combustion deposits. The electrodes are not burned or eroded. This indicates the proper type and heat range for the engine and the service.

▲NOTE

The tip should not be white. A white insulator tip indicates overheating, caused by use of an improper spark plug or incorrect EFI operation.

WET FOULED PLUG

The wet fouled insulator tip is black. A damp oil film covers the firing end. There may be a carbon layer over the entire nose. Generally, the electrodes are not worn.

General causes of fouling are excessive oil, use of non-recommended engine oil or incorrect EFI operation.

1. Remove both seats.
2. Remove the rear service panel.
3. Remove the spark plug cap.
4. Using the spark plug wrench provided in the tool kit, remove the plug by rotating it counterclockwise.
5. Reverse the procedure for spark plug installation.
Torque to specification. See page 102.

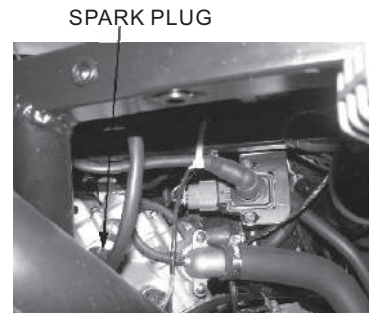

MAINTENANCE & LUBRICATION

COOLING SYSTEM

The engine coolant level is controlled or maintained by the recovery system. The recovery system components are the overflow bottle, radiator filler neck, radiator pressure cap and connecting hose. As coolant operating temperature increases, the expanding (heated) excess coolant is forced out of the radiator, past the pressure cap, and into the overflow bottle.

As engine coolant temperature decreases, the contracting (cooled) coolant is drawn back up from the tank, past the pressure cap, and into the radiator.

ADDING OR CHANGING COOLANT

To ensure that the coolant maintains its ability to protect the engine, we recommend that the system be completely drained every two years and a fresh mixture of antifreeze and water added.

We recommend the use of 60/40 anti-freeze/coolant or a 50/50 mixture of high quality aluminum compatible antifreeze/coolant and distilled water.

Premium 60/40 is already premixed and ready to use.

Do not dilute with water.

NOTE

Always follow the manufacturer's mixing recommendations for the freeze protection required in your area.

Any time the cooling system has been drained for maintenance or repair, replace the coolant. If the recovery bottle has run dry, the level in the radiator should be inspected. Add coolant as needed.

MAINTENANCE & LUBRICATION

COOLING SYSTEM

RADIATOR AND COOLING FAN

Always check and clean the screen, and radiator fins, at the intervals outlined in the Periodic Maintenance Chart beginning on page 89.

Do not obstruct or deflect airflow through the radiator by installing unauthorized accessories in front of the radiator or behind the cooling fan.

Interference with the radiator airflow can lead to overheating and consequent engine damage.

CAUTION

Washing the vehicle with a high-pressure hose could damage the radiator fins and impair the radiator's effectiveness.

Using a high-pressure system is not recommended.

MAINTENANCE & LUBRICATION

COOLANT LEVEL

Always check and change the coolant at the intervals outlined in the Periodic Maintenance Chart beginning on page 89.

Maintain the coolant level between the minimum and maximum marks on the bottle (when the fluid is cool).

1. Position the vehicle on a level surface.
2. Remove the hood.
3. View the coolant level in the overflow bottle.

If the coolant level is below the safe operating range, remove the cap and use a funnel to add coolant through the opening. Reinstall the cap.

⚠ NOTE

If coolant must be added often, or if the overflow bottle runs completely dry, there may be a leak in the system.

Have the cooling system inspected by your dealer.

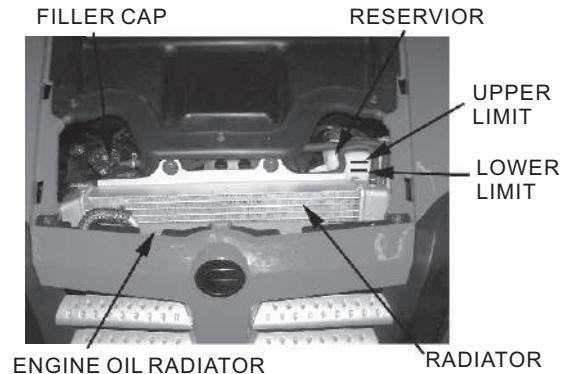

MAINTENANCE & LUBRICATION

RADIATOR COOLANT LEVEL

Always check and clean the screen and radiator fins at the intervals outlined in the Periodic Maintenance Chart beginning on page 89.

Do not obstruct or deflect airflow through the radiator by installing aftermarket accessories in front of the radiator or behind the cooling fan.

Interference with the radiator airflow can lead to overheating and consequentially, engine damage.

⚠WARNING

Escaping steam can cause severe burns.

Never remove the pressure cap while the engine is warm or hot.

Always allow the engine to cool before removing the pressure cap.

1. Remove the hood.
2. Slowly remove the radiator cap.
3. View the coolant level through the opening.
4. Use a funnel and slowly add coolant as needed.

⚠NOTE

This procedure is required only if the cooling system has been drained for maintenance and/or repair. But if the overflow bottle has run dry, the level in the radiator should also be inspected.

⚠NOTE

Use of a non-standard pressure cap will not allow the recovery system to function properly.

See your dealer for the correct replacement part.

MAINTENANCE & LUBRICATION

CONTINUOUSLY VARIABLE TRANSMISSION (CVT) SYSTEM

Belt slip is responsible for creating excessive heat that destroys belts, wears clutch components, and causes outer clutch covers to fail.

Switch to low range while operating at slower speeds to extend the life of the CVT components (belt, cover, etc.).

▲WARNING

Failure to comply with the instructions in this warning can result in severe injury or death.

Do not modify any component of the CVT system.

Doing so may reduce its strength so that a failure may occur at a high speed.

The CVT system has been precision balanced.

Any modifications will cause the system to be out of balance; creating vibrations and additional loads on components.

The CVT system rotates at high speeds, creating large amounts of force on clutch components.

Extensive engineering and testing has been conducted to ensure the safety of this product.

However, as the owner, you have the following responsibilities to make sure this system remains safe:

Always follow all recommended maintenance procedures.

See your dealer as outlined in the owner's manual.

This CVT system is intended for use on CFMOTO products only.

Do not install it in any other product.

Always make sure the CVT housing is securely in place during operation.

MAINTENANCE & LUBRICATION

CVT DRYING

There may be some instances when water is accidentally ingested into the CVT system. Use the following instructions to dry it out before operating.

1. Remove the seats.
2. Loosen the lower screws that secure the clutch cover.
3. Allow the water to drain.
4. Tighten the screws.
5. Place the transmission in PARK.
Apply the brakes.
6. Start the engine.
7. Vary the throttle for 10-15 seconds to expel the moisture and air-dry the belt and clutches.
Do not hold the throttle wide open for more than 10 seconds.
8. Allow the engine RPM to settle to idle speed.
Apply the brakes.
Shift the transmission to the lowest available range.
9. Test for belt slippage.
If the belt slips, repeat the process.
10. Take the vehicle to your dealer for service as soon as possible.

MAINTENANCE & LUBRICATION

AIR FILTER

Always change the air filter at the intervals outlined in the Periodic Maintenance Chart beginning on page 89.

Methods to clean or replace air filter element(see picture 2)

1. Loosen fix clip (3), remove air filter element cap (2);
2. Loosen screw (4), take down air filter element assembly (5);
3. Take out air filter element (6);
4. Clean filter element (6) dust and oil stains with cleaner, dry out, soak filter element (6) in engine oil, dry it properly; replace the filter element if it damaged; reinstall filter element (6) and fix it into filter case (1);
5. Tighten screw 4 in turn, coat filter element cover (2), clamping clip (3).

⚠WARNING

Do not clean the air filter element with gas or low flash point solvents.

If you replace the air filter with a aftermarket filter be sure the filter is the proper replacement, the owner will be responsible for the engine damage caused by improper filter; also the owner is responsible for the filter cleaning, maintenance etc.

⚠ATTENTION

Cleaning the air filter elements: inner dirt collector every 100 hours. Shorten this cleaning when the vehicle is used in dusty and high moisture conditions. When the filter element are dirty or improperly installed may cause reduced engine life.

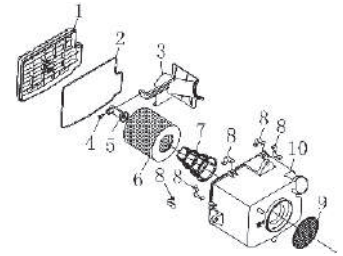

MAINTENANCE & LUBRICATION

SPARK ARRESTOR

⚠WARNING

Failure to heed the following warnings while servicing the spark arrestor could result in serious injury or death.

Do not perform clean out immediately after the engine has been run, as the exhaust system becomes very- hot. Serious burns could result from contact with the exhaust components.

Allow components to cool sufficiently before proceeding.

Wear eye protection and gloves.

Never run the engine in an enclosed area.

Exhaust contains poisonous carbon monoxide gas that can cause loss of consciousness or death in a very short time.

Periodically clean the spark arrestor to remove accumulated carbon.

1. Remove the retaining screw and remove the arrestor from the end of the muffler.
2. Use non-synthetic brushes to clean the arrestor screen. A synthetic brush may melt if components are warm.

⚠NOTE

If necessary, blow debris from the screen with compressed air.

3. Inspect the screen for wear and damage.
4. Replace a worn or damaged screen.
5. Reinstall the arrestor. Torque screws 3 to: 6-8ft.lbs (8-10Nm)

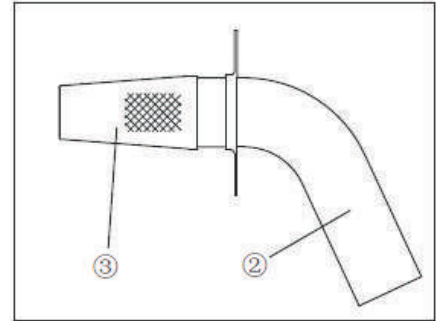

MAINTENANCE & LUBRICATION

THROTTLE

⚠WARNING

Failure to check or maintain proper operation of the throttle system can result in an accident and lead to serious injury or death if the throttle pedal sticks during operation. Never start or operate this vehicle if it has a sticking or improperly operating throttle pedal. Immediately contact your dealer for service if throttle problems arise. Always check the pedal free movement and return before starting the engine and occasionally during operation.

THROTTLE FREE PLAY

If the throttle pedal has excessive play due to cable stretch or maladjustment, it will cause a delay in throttle response, especially at low engine speed. The throttle may also not open fully.

If the throttle pedal has no free play, the throttle may be hard to control, and the idle speed may be erratic. Check the throttle pedal free play at the intervals outlined in the Periodic Maintenance Chart, beginning on page 89.

Adjust the free play if necessary.

THROTTLE FREE PLAY INSPECTION

1. Place the transmission in PARK.
2. Apply the brakes. Start the engine.
3. Allow it to warm up thoroughly.
4. Measure the distance the throttle pedal moves before the engine begins to pick up speed.

Free play should be 1/16 to 1/8 inches (1.6-3.2mm)

THROTTLE PEDAL



MAINTENANCE & LUBRICATION

THROTTLE BODY/IDLE RPM

Idle RPM is preset by the manufacturer. If the engine idle speed is not satisfactory, please see your dealer for adjustment.

THROTTLE FREE PLAY ADJUSTMENT

1. Remove both seats. Remove the rear service panel.
2. Locate the throttle cable adjuster.
3. Squeeze the end of the rubber boot and slide it far enough to expose the end of the inline cable adjuster.
4. Loosen the adjuster lock nut.
5. Rotate the boot to turn the adjuster until 1/16" to 1/8" (1.6-3.2mm) of free play is achieved at the throttle pedal. See page 112.

▲ NOTE

While adjusting, lightly flip the throttle pedal up and down.

6. Tighten the lock nut.
7. Squeeze the end of the rubber boot and slide it over the cable adjuster to its original position.

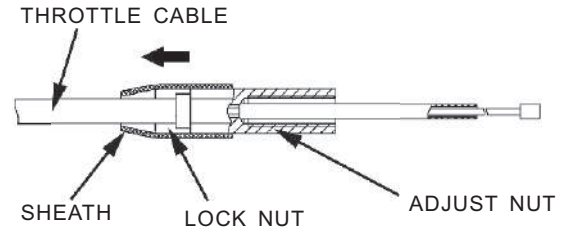

MAINTENANCE & LUBRICATION

BRAKES

The front and rear brakes are hydraulic disc type brakes activated by the brake pedal.

Always check brake pedal travel and the brake fluid, reservoir level, before each use of the vehicle. When applied, the brake pedal should feel firm. Any sponginess would indicate a possible fluid leak or low brake fluid level, which must be corrected before riding.

See page 115, for brake fluid information.

If you discover any irregularities in brake system operation, including excessive pedal travel, contact your dealer for proper diagnosis and repairs.

⚠WARNING

Operating the vehicle with a spongy brake pedal can result in loss of braking, which could cause an accident resulting in severe injury or death. Never operate the vehicle with a spongy-feeling brake pedal.

MAINTENANCE & LUBRICATION

BRAKE FLUID

Inspect the level of the brake fluid before each operation. If the fluid level is low, add DOT 4 brake fluid only. Change the brake fluid every two years and any time the fluid becomes contaminated, the fluid level is below the minimum, or if the type and brand of the fluid in the reservoir are unknown. Access the brake fluid reservoir through the left front wheel well.

1. Position the vehicle on a level surface.
2. Place the transmission in PARK.
3. View the brake fluid level in the reservoir. The level should be between the maximum and minimum level lines.
4. If the fluid level is lower than the lower level line, add brake fluid to the upper line.
5. Apply the brake forcefully for a few seconds and check for fluid leakage around the fittings.

⚠WARNING

After opening a bottle of brake fluid, always discard any unused portion. Never store or use a partial bottle.

Brake fluid is hygroscopic, meaning it rapidly absorbs moisture from the air. The moisture causes the boiling temperature of the brake fluid to drop, which can lead to early brake fade and the possibility of accident or severe injury.

MAINTENANCE & LUBRICATION

BRAKE INSPECTION

1. Check the brake system for fluid leaks.
2. Check the brake pedal for excessive travel or a spongy feel.
3. Check the friction pads for wear, damage, and looseness.
4. Inspect the brake pad wear surface for excessive wear.
5. Change pads when worn to 3/64" (1 mm).

STEERING WHEEL INSPECTION

Check the steering wheel for specified free play and smooth operation at the intervals outlined in the Periodic Maintenance Chart beginning on page 89.

1. Position the vehicle on level ground.
2. Lightly turn the steering wheel left and right.
3. There should be 0.8 "-1.0" (20-25mm) of free play.
4. If there is excessive free play or strange noises, or the steering feels rough or "catchy", have the steering system inspected by an authorized CFMOTO dealer.

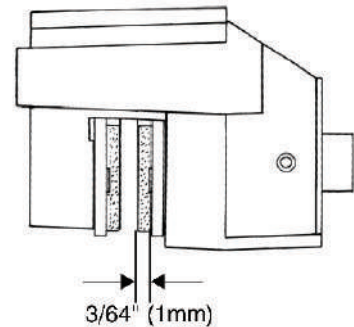

MAINTENANCE & LUBRICATION

SUSPENSION ADJUSTMENT

The front and rear suspensions are preload adjustable, with five settings on each axle.

The suspensions are set on the lowest (softest) setting at the factory. This setting is appropriate for nearly all riding conditions. Since the vehicle is equipped with full skid plates, suspension adjustment is not necessary. If desired, the suspension may be adjusted to maintain vehicle clearance height when carrying loads. Please see your CFMOTO dealer for the tool required to make suspension adjustments. Elevate the vehicle slightly for easier adjustment. Always heed the following rules if you make adjustments to this suspension. Always return the suspension to the lowest (softest) setting after the load is removed from the vehicle. The increased suspension height will negatively impact vehicle stability when operating without a load. Always apply the same adjustment setting to all four wheels. Never operate the vehicle on the highest (stiffest) or second highest preload settings without a total combined payload in the vehicle of 450 lbs (204 kg) or more. Payload includes the driver, passenger, CFMOTO approved accessories and cargo. Never exceed the stated load capacity for this vehicle.

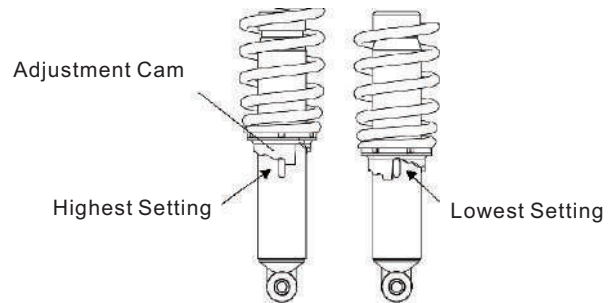

OPTIONAL SHOCK ABSORBER ADJUSTMENT (FRONT ADJUSTMENT PROCEDURES)

Spring adjustment:

Loosen lock nut (2). Turn adjust nut (3) to proper hardness, and then tighten lock nut (2).

DAMPING RESTORE ADJUSTMENT

Turn adjuster (4) to SLOW side until to end and counter shifts, then turn to FAST side until suitable to your comfort.

Damping press adjustment :

Turn adjuster (1) to HARD side and counter shifts, and then turn to SOFT side until suitable to your comfort.

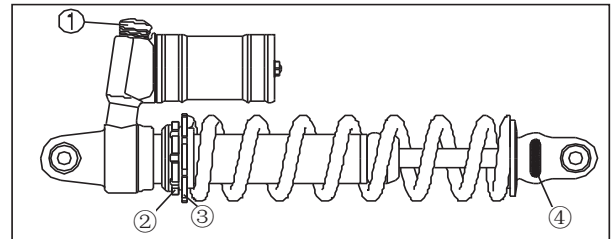

▲ ATTENTION

After adjustment, keep left and right shock absorber balance.

OPTIONAL 2 SHOCK ABSORBER ADJUSTMENT (REAR ADJUSTMENT PROCEDURES)

Spring adjustment :

Loosen lock nut (3). Turn adjust nut (2) to proper hardness, then tighten lock nut (3).

Damping restore adjustment :

Turn adjuster (1) to SLOW side until to end and counter shifts. Then turn to FAST side until suitable to your comfort. Damping press is not possible to adjust.

⚠ ATTENTION

After adjustment, keep left and right shock absorber balance.

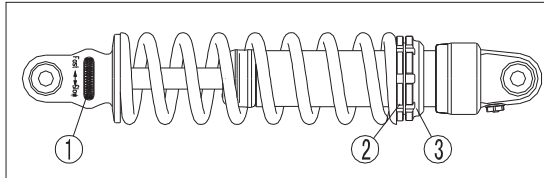

MAINTENANCE & LUBRICATION

TIRES

Operating your vehicle with worn tires will increase the possibility of skidding, loss of control and an accident, which could result in serious injury or death. Always replace tires when the tread depth measures 1/8" (3 mm) or less. Improper tire inflation or the use of non-standard size or type of tires may adversely affect vehicle handling, which could result in vehicle damage or personal injury. Always maintain proper tire pressure. When replacing tires, always use original equipment size and type.

TIRE TREAD DEPTH

Always replace tires when tread depth is worn to 1/8" (3 mm) or less.

Axle and Wheel Nut Torque Specifications

Inspect the following items occasionally for tightness, and if they've been loosened for maintenance service.

Wheel Type	Nut Type	Location	Nut Torque
Rim (Aluminum)	Nut	Front and Rear	75Nm
Rim (Steel)	Nut	Front and Rear	75Nm
Any	Wheel Seat Support Retaining Nut	Front and Rear	120Nm

NOTE

Do not lubricate the stud or the lug nut.

MAINTENANCE & LUBRICATION



Cast Aluminum



75Nm



Steel



75Nm

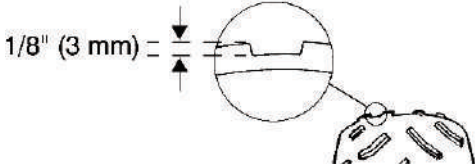

MAINTENANCE & LUBRICATION

TIRES

Improperly installed wheels can adversely affect tire wear and vehicle handling, which can result in serious injury or death. Always ensure that all nuts are torqued to specification. Do not service axle nuts that have a cotter pin installed. See your dealer.

WHEEL REMOVAL

1. Position the vehicle on a level surface.
2. Place the transmission in PARK. Stop the engine.
3. Loosen the wheel nuts slightly.
4. Elevate the side of the vehicle by placing a suitable stand under the frame.
5. Remove the wheel nuts and washers.6.Remove the wheel.

WHEEL INSTALLATION

1. Place the transmission in PARK.
2. Place the wheel in the correct position on the wheel hub. Be sure the valve stem is toward the outside and rotation arrows on the tire point toward forward rotation.
- 3 Attach the wheel nuts and washers and finger tighten.
4. Carefully lower the vehicle to the ground.
5. Torque the wheel nuts to specification.

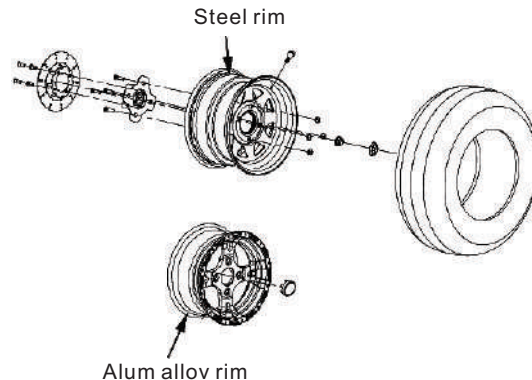

MAINTENANCE & LUBRICATION

LIGHTS

When servicing a halogen lamp, don't touch the lamp with bare fingers. Oil from your skin leaves a residue, causing a hot spot that will shorten the life of the lamp.

⚠WARNING

Poor lighting while driving can result in severe injury or death. Headlight and taillight lenses become dirty during normal operation. Wash the headlights frequently to maintain lighting quality. Hot components can cause serious burns to skin. Do not service the headlamps until they've cooled sufficiently.

HEADLIGHT LAMP REPLACEMENT

1. Unplug the headlamp from the wiring harness. Be sure to pull on the connector, not on the wiring.
2. Turn the lamp counter- clockwise to remove it.
3. Install the new lamp 1.

⚠NOTE

Make sure the tab on the lamp locates properly in the housing.

4. Reinstall the harness assembly into the head light assembly.

Headlamp rear cover



Bolt

Dust cover

Tab

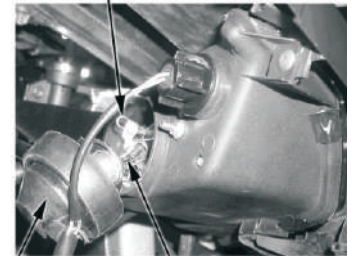

Lamp

MAINTENANCE & LUBRICATION

HEADLIGHT BEAM ADJUSTMENT

1. Place the vehicle on a level surface with the headlight approximately 25 ft. (7.6 m) from a wall. Place the transmission in PARK.
2. Measure the distance from the floor to the center of the headlight and make a mark on the wall at the same height.
3. Apply the brakes. Start the engine. Turn on the headlights.
4. Observe the headlight aim. The most intense part of the headlight beam should be aimed 8" (20 cm) below the mark placed on the wall in step 2.

⚠ NOTE

Include the weight of a rider on the seat while performing this step.

5. If adjustment is necessary, turn the headlight adjustment screw to adjust the beam.
6. Repeat steps 4-5 until the beam is properly adjusted.

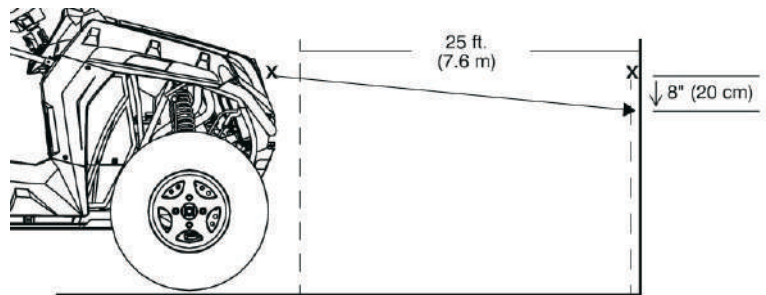

MAINTENANCE & LUBRICATION

BRAKE LIGHTS

When the brake pedal is depressed, the brake light comes on. Check the brake light before each ride.

1. Turn the ignition switch to the ON position.
2. Apply the brakes. The brake light should come on after about 10 mm (0.4 in.) of pedal travel. If the light doesn't come on, check the bulb.

VEHICLE IMMERSION

CAUTION

If your vehicle becomes immersed, major engine damage can result if the machine is not thoroughly inspected. Take the vehicle to your dealer before starting the engine.

If it's impossible to take your vehicle to a dealer before starting it, follow the steps outlined below.

Move the vehicle to dry land.

1. Check the air box. If water is present, dry the air box and replace the filter with a new filter. Thoroughly dry the air pre-filter. See page 110.
2. Remove the spark plug.
3. Turn the engine over several times.
4. Dry the spark plugs and reinstall them, or install new plugs.

NOTE

Attempt to start the engine. If necessary, repeat the drying procedure.

5. Take the vehicle to your dealer for service as soon as possible, whether you succeed in starting it or not.

NOTE

If water has been ingested into the CVT follow the procedure on page 109 for drying.

MAINTENANCE & LUBRICATION

BATTERY

Your vehicle may have either a sealed battery, which requires little maintenance, or a conventional battery. A sealed battery can be identified by its flat covers on the top of the battery. A conventional battery has six-filler caps on the top of the battery. Always keep battery terminals and connections free of corrosion. If cleaning is necessary, remove the corrosion with a stiff wire brush. Wash with a solution of one-tablespoon baking soda and one-cup water. Rinse well with tap water and dry off with clean shop towels. Coat the terminals with dielectric grease or petroleum jelly. Be careful not to allow cleaning solution or tap water into a conventional battery.

⚠WARNING

Battery electrolyte is poisonous. It contains sulfuric acid. Serious burns can result from contact with skin, eyes or clothing.

⚠ANTIDOTE

External: Flush with water.

Internal: Drink large quantities of water or milk. Follow with milk of magnesia, beaten egg, or vegetable oil. Call physician immediately.

Eyes: Flush with water for 15 minutes and get prompt medical attention.

⚠WARNING

Batteries produce explosive gases. Keep sparks, flame, cigarettes, etc. away. Ventilate when charging or using in an enclosed space. Always shield eyes when working near batteries. **KEEP OUT OF REACH OF CHILDREN.**

MAINTENANCE & LUBRICATION

BATTERY

Improperly connecting or disconnecting battery cables can result in an explosion and cause serious injury or death. When removing the battery always disconnect the negative (black) cable first. When reinstalling the battery, always connect the negative (black) cable last.

BATTERY REMOVAL

1. Remove the driver's seat.
2. On conventional batteries, remove the battery vent tube.
3. Disconnect the black (negative) battery cable first.
4. Disconnect the red (positive) battery cable last.
5. Lift the battery out of the vehicle. Be careful not to tip a conventional battery sideways, which could spill electrolyte.

MAINTENANCE & LUBRICATION

BATTERY INSTALLATION

Using a new battery that has not been fully charged can damage the battery and result in a shorter life. It can also hinder vehicle performance.

Follow the battery charging instructions on page 130, before installing the battery.

1. Ensure that the battery is fully charged.
2. Place the battery in the battery holder.
3. On conventional batteries, install the battery vent tube (sealed batteries do not have a vent tube).

▲NOTE The vent tube must be free of obstructions and securely installed.

Route the tube away from the frame and vehicle body to prevent contact with electrolyte.

▲WARNING

Battery gases could accumulate in an improperly installed vent tube and cause an explosion, resulting in serious injury or death. Always ensure that the vent tube is free of obstructions and is securely installed as recommended.

4. Coat the terminals with dielectric grease or petroleum jelly.
5. Connect and tighten the red (positive) cable first.
6. Connect and tighten the black (negative) cable last.
7. Verify that cables are properly routed.
8. Reinstall the driver's seat.

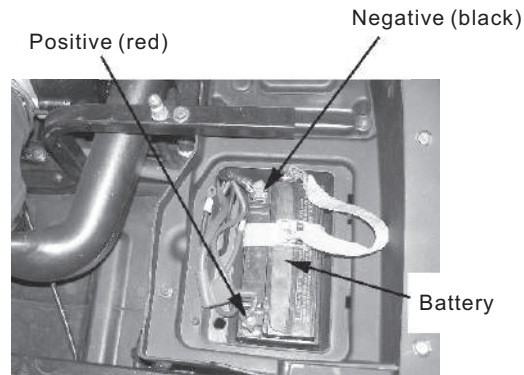

MAINTENANCE & LUBRICATION

BATTERY STORAGE

Whenever the vehicle is not used for a period of three months or more remove the battery from the vehicle, ensure that it's fully charged, and store it out of the sun in a cool, dry place. Check battery voltage each month during storage and recharge as needed to maintain a full charge.

▲NOTE

Battery charge can be maintained by using a CFMOTO Battery Tender charger or by charging about once a month to make up for normal self-discharge. Battery Tender can be left connected during the storage period, and will automatically charge the battery if the voltage drops below a pre-determined point.

BATTERY FLUID

A poorly maintained battery will deteriorate rapidly. Check the battery fluid level often.
Battery volume: 12V 30Ah

MAINTENANCE & LUBRICATION

BATTERY CHARGING (CONVENTIONAL BATTERY)

1. Remove the battery from the vehicle to prevent damage from leaking or spilled electrolyte during charging. See page 127.
2. Charge the battery with a charging output no larger than 1/10 of the battery's amp/hr rating.
3. Charge as needed to raise the specific gravity to 1.270 or greater.
4. Reinstall the battery. See page 128.

BATTERY CHARGING (SEALED BATTERY)

The following battery charging instructions apply only to the installation of a sealed battery.

Read all instructions before proceeding with the installation of this battery.

The sealed battery is already filled with electrolyte and has been sealed and fully charged at the factory. Never pry the sealing strip off or add any other fluid to this battery. The single most important thing about maintaining a sealed battery is to keep it fully charged. Since the battery is sealed and the sealing strip cannot be removed, you must use a voltmeter, or multimeter to measure DC voltage.

⚠WARNING

An overheated battery may explode, causing severe injury or death. Always watch charging times carefully. Stop charging if the battery becomes very warm to the touch. Allow it to cool before resuming charging.

For a refresh charge, follow all instructions carefully.

1. Check the battery voltage with a voltmeter or multimeter. A fully charged battery will register 12.8 V or higher.
2. If the voltage is less than 12.8 volts, recharge the battery at 1.2 amps or less until battery voltage is 12.8 or greater.

MAINTENANCE & LUBRICATION

⚠ NOTE When using an automatic charger, refer to the charger manufacturer's instructions for recharging. When using a constant current charger, use the guidelines on the next page for recharging.

BATTERY CHARGING (SEALED BATTERY)

⚠ NOTE Always verify battery condition, before and 1-2 hours after, the end of charging.

State of Charge	Voltage	Action	Charge Time
100%	12.8-13.0V	None	None required
75%-100%	12.5-12.8V	May need slight charge, if no charge given, check in 3 months	3-6 hours
50%-75%	12.0-12.5V	Needs charge	5-11hours
25%-50%	11.5-12.0V	Needs charge	At least 13 hours, verify state of charge

CLEANING AND STORAGE

WASHING THE VEHICLE

Keeping your vehicle clean will not only improve its appearance but it can also extend the life of various components.

⚠ CAUTION

High water pressure may damage components. CFMOTO recommends washing the vehicle by hand or with a garden hose, using mild soap. Certain products, including insect repellents and chemicals, will damage plastic surfaces.

Do not allow these types of products to contact the vehicle.

1. The best and safest way to clean your vehicle is with a garden hose and a pail of mild soap and water.
2. Use a professional-type washing cloth, cleaning the upper body first and the lower parts last.
3. Rinse with clean water frequently.
4. Dry surfaces with a chamois to prevent water spots.

WASHING TIPS

- Avoid the use of harsh cleaners, which can scratch the finish.
- Do not use a power washer to clean the vehicle.
- Do not use medium to heavy-duty compounds on the finish.
- Always use clean cloths and pads for cleaning and polishing. Old or reused cloths and pads may contain dirt particles that will scratch the finish.

CLEANING AND STORAGE

WASHING THE VEHICLE

If a high-pressure water system is used for cleaning (not recommended), exercise extreme caution. The water may damage components and could remove paint and decals. Avoid directing the water stream at the following items:

- Wheel bearings
- Radiator
- Transmission seals
- Brakes
- Cab and body panels
- Labels and decals
- Electrical components and wiring

NOTE

If warning and safety labels are damaged, contact your CFMOTO dealer for free replacement. Grease all zerk fittings immediately after washing. Allow the engine run for a while to evaporate any water that may have entered the engine or exhaust system.

POLISHING THE VEHICLE

CFMOTO recommends the use of common household aerosol furniture polish for polishing the finish on your CFMOTO vehicle. Follow the instructions on the container.

POLISHING TIPS

- * Avoid the use of automotive products, some of which can scratch the finish of your vehicle.
- * Always use clean cloths and pads for cleaning and polishing. Old or reused cloths and pads may contain dirt particles that will scratch the finish.

CLEANING AND STORAGE

CHROME WHEEL CARE(IF EQUIPPED)

Proper maintenance will protect chrome wheels from corrosion, preserve wheel life, and ensure a “like new” appearance for many years.

▲NOTE

Chrome wheels exposed to road salt(or salt in the air; in coastal areas) are more susceptible to corrosion if not properly cleaned. Clean chrome wheels more often if they're exposed to salt or other corrosive elements.

1. Wash chrome wheels frequently.
2. Use a mild detergent. Never use abrasive cleaners on plated or painted surfaces.
2. Rinse well with clear water. Soap, detergents, salt, dirt, mud and other elements can cause corrosion.
3. Polish the clean chrome wheels periodically. Use an automotive grade chrome polish.
4. Routinely and liberally apply a weather resistant wax to each polished chrome wheel.

Choose a product suitable for chrome finishes.

Read and follow the product labels and instructions.

REMOVING CORROSION

If light rust is found on the chrome finish, use steel wool (#0000-OTT grade) to remove it.

Gently rub the affected areas with the steel wool until the corrosion has been removed.

Clean and polish the wheel as outlined above.

CLEANING AND STORAGE

STORAGE TIPS

⚠ CAUTION

Starting the engine during the storage period will disturb the protective film created by fogging, and damage could occur.

Never start the engine during the storage period.

CLEAN THE EXTERIOR

Make any necessary repairs and clean the vehicle as recommended.

STABILIZE THE FUEL

1. Fill the fuel tank.
2. Add CFMOTO Carbon Clean Fuel Treatment or CFMOTO Fuel Stabilizer. Follow the instructions on the container for the recommended amount.

⚠ NOTE

Carbon Clean Fuel Treatment removes water fuel systems, stabilizes fuel and removes carbon deposits from pistons, rings, valves and exhaust systems.

3. Allow the engine to run for 15-20 minutes to allow the stabilizer to disperse through the entire fuel delivery system.

OIL AND FILTER

Change the oil and filter. See page 97.

AIR FILTER / AIR BOX

Inspect and clean or replace the pre-filter and air filter. See page 110. Clean the air box. Drain the sediment tube.

CLEANING AND STORAGE

FLUID LEVELS

Inspect the fluid levels.

Add or change fluids as recommended in the Periodic Maintenance Chart beginning on page 89.

- * Demand drive fluid (front gear case)
- * Rear gear case fluid
- * Transmission fluid
- * Brake fluid (change every two years and any time the fluid looks dark or contaminated.)
- * Coolant (test strength/fill)

CLEANING AND STORAGE

INSPECT AND LUBRICATE

Inspect all cables and lubricate all areas of the vehicle as recommended in the Periodic Maintenance Chart beginning on page 89.

FOG THE ENGINE

1. Treat the fuel system with CFMOTO Carbon Clean, Follow the instructions on the container. Start the engine. Allow it to idle for several minutes so the Carbon Clean reaches the injectors. Stop the engine.
2. Remove the spark plugs and add 2-3 tablespoons of Premium 4 Synthetic 0W40 engine oil. To access the plug holes, use a section of clear 1/4" hose and a small plastic squeeze bottle filled with the premeasured amount of oil.

NOTE

Do this carefully. If you miss the plug holes, oil will drain the spark plug cavities into the hole at the front of the cylinder head, and appear to be an oil leak.

3. Reinstall the spark plugs; torque to specification.
4. Apply dielectric grease to the inside of each spark plug cap. Do not reinstall the caps onto the plugs at this step.
5. Turn the engine over several times. Oil will be forced in and around the piston rings and ring lands, coating the cylinder with a protective film of fresh oil.
6. If CFMOTO fuel system additive is not used, fuel tank, fuel lines, and injectors should be completely drained of gasoline.
7. Reinstall the spark plug caps to the spark plugs.

CLEANING AND STORAGE

BATTERY MAINTENANCE

See pages 129 for storage and charging procedures.

STORAGE AREA/COVERS

Be sure the storage area is well ventilated.

⚠ NOTE

Do not use plastic or coated materials. They do not allow enough ventilation to prevent condensation, and may promote corrosion and oxidation.

CLEANING AND STORAGE

REMOVAL FROM STORAGE

1. Check the battery electrolyte level and charge the battery if necessary.
2. Install it in the vehicle. Make sure the battery vent hose is routed properly and that it's not pinched or restricted in any way.
3. Make sure the spark plug is tight.
4. Fill the fuel tank with fuel.
5. Check all the points listed in the Daily Pre-Ride Inspection section on page 66.

▲NOTE

Tightness of the bolts, nuts and other fasteners should be checked by an authorized CFMOTO dealer.

6. Lubricate at the intervals outlined in the Periodic Maintenance Chart beginning on page 91.

▲WARNING

Engine exhaust contains poisonous carbon monoxide and can cause loss of consciousness or death. Never run an engine in an enclosed area.

TRANSPORTING THE VEHICLE

Follow these procedures when transporting the vehicle.

1. Place the transmission in PARK. Stop the engine.
2. Remove the key to prevent loss during transporting.
3. Secure the fuel cap and seats.
4. Always tie the frame of the CFMOTO vehicle to the transporting unit securely with suitable straps or rope. Do not attach tie straps to the front control arm bolt pockets.

TROUBLESHOOTING

DRIVE BELT AND COVER PROBLEMS

POSSIBLE CAUSE	SOLUTION
Driving the UTV onto a pickup or tall trailer in high range.	Shift transmission to low range during loading of the UTV to prevent belt burning.
Starting out going up a steep incline.	When starting out on an incline, use low range or dismount the UTV (after first applying the park brake) and perform the K-turn .
Driving at low RPM or low ground speed(at approximately 5–10 km/h).	Drive at a higher speed or use low range more frequently. The use of low range is highly recommended for cooler CVT operating temperatures and longer component life.
Insufficient warm-up of UTV exposed to low ambient temperatures.	Warm the engine before driving, the belt will become more flexible and prevent belt burning.
Slow and easy clutch engagement.	Use the throttle quickly and effectively for efficient engagement.
Towing/pushing at lowRPM/low ground speed.	Use low range only.
Utility use/plowing snow, dirt, etc.	Use low range only.

TROUBLESHOOTING

POSSIBLE CAUSE	SOLUTION
Stuck in mud or snow.	Shift the transmission to low range, and carefully use fast, aggressive throttle application to engage clutch. WARNING: Excessive throttle may cause loss of control and vehicle overturn.
Climbing over large objects from a stopped position.	Shift the transmission to low range, and carefully use fast, brief, aggressive throttle application to engage clutch. Excessive throttle may cause loss of control and vehicle overturn.
Belt slippage from water or snow ingestion into the CVT system.	Remove the CVT cover, drain the water from CVT.
Clutch malfunction.	Contact your dealer for inspection of clutch components.

TROUBLESHOOTING

ENGINE DOESN'T TURN OVER

POSSIBLE CAUSE	SOLUTION
Poor engine performance.	Check for fouled plugs or foreign material in gas tank, fuel lines, or throttle. Contact your dealer for service.
Tripped circuit breaker	Reset the breaker
Low battery voltage	Recharge battery to 12.5 VDC
Loose battery connections	Check all connections and tighten
Loose solenoid connections	Check all connections and tighten

ENGINE PINGS OR KNOCKS

POSSIBLE CAUSE	SOLUTION
Poor quality or low octane fuel	Replace with recommended fuel
Incorrect ignition timing	See your dealer
correct spark plug gap or heat range	Set gap to specs or replace plugs

ENGINE STOPS OR LOSES POWER

POSSIBLE CAUSE	SOLUTION
Overheated engine	Clean radiator screen and core if equipped Clean engine exterior See your dealer

TROUBLESHOOTING

ENGINE TURNS OVER, FAILS TO START

POSSIBLE CAUSE	SOLUTION
Out of Fuel	Refuel
Clogged fuel valve or filter	Inspect and clean or replace
Water is present in fuel	Drain the fuel system and refuel
Fuel valve is out of use	Replace
Old or non-recommended fuel	Replace with new fuel
Fouled or defective spark plug(s)	Inspect plug(s), replace if necessary
No spark to spark plug	Inspect plug (s) , verify stop switch is on
Crankcase filled with water or fuel	Immediately see your dealer
Clogged fuel injector	Clean or replace new fuel injector
Low battery voltage	Recharge battery to 12.5 VDC
Mechanical failure	See your dealer

TROUBLESHOOTING

ENGINE BACKFIRES

POSSIBLE CAUSE	SOLUTION
Weak spark from spark plugs	Inspect, clean and/or replace spark plugs
Incorrect spark plug gap or heat range	Set gap to specs or replace plugs
Old or non-recommended fuel	Replace with new fuel
Incorrectly installed spark plug wires	See your dealer
Incorrect ignition timing	See your dealer
Mechanical failure	See your dealer

ENGINE RUNS IRREGULARLY, STALLS OR MISFIRES

POSSIBLE CAUSE	SOLUTION
Fouled or defective spark plugs	Inspect, clean and/or replace spark plugs
Worn or defective spark plug wires	See your dealer
Incorrect spark plug gap or heat range	Set gap to specs or replace plugs
Loose ignition connections	Check all connections and tighten
Water present in fuel	Replace with new fuel
Low battery voltage	Recharge battery to 12.5 VDC

TROUBLESHOOTING

ENGINE RUNS IRREGULARLY, STALLS OR MISFIRES

POSSIBLE CAUSE	SOLUTION
Kinked or plugged fuel vent line	Inspect and replace
Incorrect fuel	Replace with recommended fuel
Clogged air filter	Inspect and clean or replace
Reverse speed limiter malfunction	See your dealer
Electronic throttle control malfunction	See your dealer
Other mechanical failure	See your dealer
Possible Lean or Rich Fuel Mixture	See your dealer
Low or contaminated fuel	Add or change fuel, clean the fuel system
Low octane fuel	Replace with recommended fuel
Clogged fuel filter	Replace filter
Incorrect jetting	See your dealer
Fuel is very high octane	Replace with lower octane fuel

TROUBLESHOOTING

ENGINE STOPS OR LOSES POWER

POSSIBLE CAUSE	SOLUTION
Out of fuel	refuel
Kinked or plugged fuel vent line	Inspect and replace
Water present in fuel	Replace with new fuel
Fouled or defective spark plugs	Inspect, clean and/or replace spark plugs
Worn or defective spark plug wires	See your dealer
Incorrect spark plug gap or heat range	Set gap to specs or replace plugs
Loose ignition connections	Check all connections and tighten
Low battery voltage	Recharge battery to 12.5 VDC
Clogged air filter	Inspect and clean or replace
Reverse speed limiter malfunction	See your dealer
Electronic throttle control malfunction	See your dealer
Other mechanical failure	See your dealer

TROUBLESHOOTING

PCODE LIST

PCODE uses 4-digit flashing :

For Example "0650" "0" flashes 10 times, "6" flashes 6 times, "5" flashes 5 times, "0" flashes 10 times.

NO	PCODE	FAIURE ANALYSIS
13	P0131	02S 1 Circuit Low Voltage
14	P0132	02S 1 Circuit High Voltage
15	P0032	02S 1 Heater Circuit High Votage
16	P0031	02S 1 Heater Circuit Low Voltage
17	P0201	Injector 1 Circuit Malfunction
18	P0202	Injector 2 Circuit Malfuntion
19	P0230	FPR Coil Circuit Low Voltage or Open
20	P0232	FPR Coil Circuit High Voltage
21	P0336	CKP Sensor Noisy Signal
22	P0337	CKP Sensor No signal
23	P0351	Cylinder 1 Ignition Coil Malfunction
24	P0352	Cylinder 2 Ignition Coil Malfunction
29	P0505	Idle Speed Control Error

TROUBLESHOOTING

NO	PCODE	FAIURE ANALYSIS
30	P0562	System Voltage Low(Battery)
31	P0563	System Voltage High(Battery)
32	P0650	MIL Circuit Malfunction
33	P0693	Tachometer (RPM) Circuit Low Voltage
36	P0694	Tachometer (RPM) Circuit High Voltage
37	P0317	02S 2 Circuit Low Voltage
38	P0318	02S 2 Circuit High Voltage
39	P0038	02S Heater 2 Circuit High Voltage
51	P0037	02S Heater 2 Circuit Low Voltage
52	P0500	VSS No Sibnal
60	P0850	Park Neutral Switch Error
61	P0445	CCP short to high
62	P0444	CCP short to low/open

SPECIFICATIONS

ITEM	CF600-3(Z6)	CF600-6(Z6 EX)
Gross Vehicle Weight LBS (kg)	1,326 lbs (495kg)(With full engine oil and fuel)	1,326 lbs (495kg)(With full engine oil and fuel)
Fuel Capacity Gal (lit)	7.1 Gal (27L)	7.1 Gal (27L)
Engine Oil Capacity Qt (ml)	2.5 qt (2800ml) (first time) 2.6 qt (2500ml) (replace)	2.5 qt (2800ml) (first time) 2.6 qt (2500ml) (replace)
Coolant Capacity Qt (ml)	2.8 qt (2720ml)	2.8 qt (2720ml)
Rear Gearcase Oil Capacity Qt (ml)	.6 pt (300ml) (first time) .5 pt (250ml) (replace)	.6 pt (300ml) (first time) .5 pt (250ml) (replace)
Transfer Case Oil Capacity	330ml (first time), 280ml (replace)	330ml (first time), 280ml (replace)
L loadable Weight Capacity LBS (kg)	267 lbs (100kg)	267 lbs (100kg)
Maximum Weight Capacity (Payload) LBS (kg)	669 lbs (250kg) (riders/cargo/accessories)	669 lbs (250kg) (riders/cargo/accessories)
Receiver Hitch Tongue Capacity LBS (kg)	133 lbs (50kg)	133 lbs (50kg)
Receiver Hitch Towing Capacity LBS (kg)	334 lbs (125kg) (including trailer and cargo)	334 lbs (125kg) (including trailer and cargo)
Overall Length in (mm)	103 in (2630mm)	103 in (2630mm)
Overall Width in (mm)	51.9 in (1320mm)	Choose 12 in. tire: 1565mm Choose 14 in. tire: 1590mm
Overall Height in (mm)	70.8 in (1800mm)	73.1 in (1860mm)
Wheelbase in (mm)	77.1 (1960mm)	77.1 (1960mm)
Minimum turning radius ft (m)	16. ft (5.0m)	16. ft (5.0m)
Ground Clearance in (mm)	9.4 in (240mm)	9.4 in (240mm)

SPECIFICATIONS

ITEM	CF600-3(Z6)	CF600-6(Z6 EX)
ENGINE NO.	196S-C	196S-C
ENGINE TYPE	Single cylinder, 4 valve 4 stroke with counterbalance	Single cylinder, 4 valve 4 stroke with counterbalance
Displacement	593ml	593ml
Bore x Stroke	96mm×82mm	96mm×82mm
Alternator Output	300W, 5000 r/min	300W, 5000 r/min
Compression Ratio	10.0:1	10.0:1
Starting System	Electric	Electric
Fuel System	EFI (Electronic fuel injection)	EFI (Electronic fuel injection)
Ignition System	ECU	ECU
Spark Plug / Gap	NGK:DPR7EA-9/0.8-0.9	NGK:DPR7EA-9/0.8-0.9
Front Suspension	Independent double arm	Independent double arm
Rear Suspension	Independent double arm	Independent double arm
Lubrication System	Compression Wet Sump	Compression Wet Sump
Engine Oil	SAE15W/40 SG	SAE15W/40 SG
Driving System Type	Front/Rear gear output	Front/Rear gear output
Shift Type	Dual Range/L-H-N-R	Dual Range/L-H-N-R
Gear Reduction - Low	5.857	5.857

SPECIFICATIONS

ITEM	CF600-3(Z6)	CF600-6(Z6 EX)
Gear Reduction – Reverse	3.828	3.828
Gear Reduction - High	3.514	3.514
Drive Ratio - Front	3.667(33/9)	3.667(33/9)
Drive Ratio - Final	3.667(33/9)	3.667(33/9)
Tire Size - Front	25×8-12 77J	25×8-12 77J
	205/80-12 77J	205/80-12 77J
Tire Size - Rear	25×10-12 85J	25×10-12 85J
	255/65-12 85J	255/65-12 85J
Tire Pressure - Front	70kPa	70kPa
Tire Pressure - Rear	84kPa	84kPa
Brakes, Front/ Rear	Foot Activated, 4-wheel hydraulic disc	Foot Activated, 4-wheel hydraulic disc
Front trunk Loadable	10kg	10kg
Headlight	35W/35W×2	35W/35W×2
Brake light	21W/5W×2	21W/5W×2
Rear position light	5W×2	5W×2
Front position light	5W×2	5W×2
Dashboard	LCD Dashboard	LCD Dashboard
Auxiliary DC Outlet	12V Maximal current: 10A	12V Maximal current: 10A

Wiring diagram

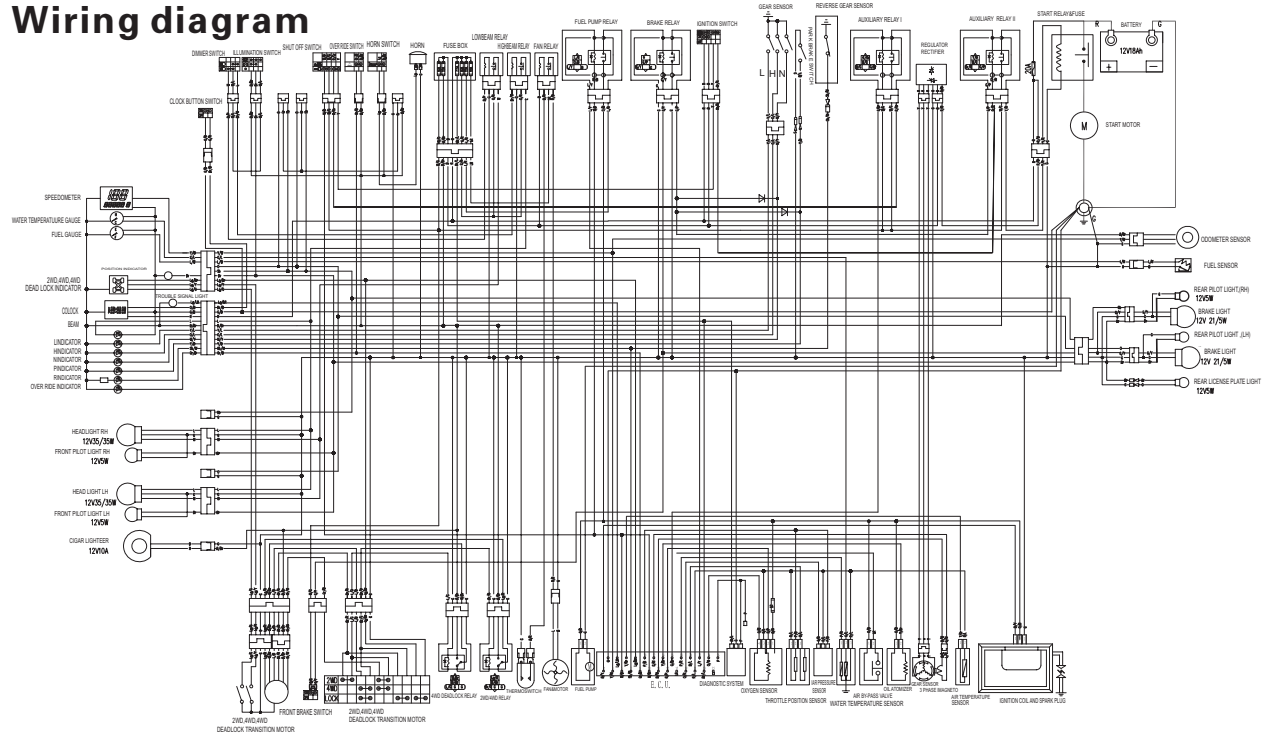

CODE	R	R/W	B	B/W	B/Y	B/Br	B/L	B/R	G	G/R	G/Y	G/B	G/W	G/L	L	L/R	L/B	L/W	L/G	O	O/B	O/W	O/L	W	W/Y	W/L	W/B	W/G	W/B	Lg/LR
COLOR	RED	WHITE	BLACK	BLACK/WHITE	BLACK/YELLOW	BLACK/BROWN	BLACK/BLUE	BLACK/RED	GREEN	GREEN/RED	GREEN/YELLOW	GREEN/BLACK	GREEN/WHITE	GREEN/BLUE	BLUE	BLUE/RED	BLUE/BLACK	BLUE/WHITE	BLUE/GREEN	ORANGE	ORANGE/BLACK	ORANGE/WHITE	ORANGE/BLUE	WHITE	WHITE/YELLOW	WHITE/BLUE	WHITE/BROWN	WHITE/GREEN	WHITE/BLACK	LIGHT GREEN/PINK
COLOR	Y	Y/W	Y/R	Y/B	Y/L	Gr	Gr/R	Gr/W	Gr/B	Br	Br/R	Br/L	Br/W	Br/B	Lg	Lg/R	Lg/G	Lg/Y	Lg/Br	Lg/B	Sb	Sb/W								P
COLOR	YELLOW	YELLOW/WHITE	YELLOW/RED	YELLOW/BLACK	YELLOW/BLUE	GREY	GREY/RED	GREY/WHITE	GREY/BLACK	BROWN	BROWN/RED	BROWN/BLUE	BROWN/GREEN	BROWN/WHITE	BROWN/BLACK	LIGHT GREEN	LIGHT GREEN/RED	LIGHT GREEN/GREEN	LIGHT GREEN/YELLOW	LIGHT GREEN/BROWN	LIGHT GREEN/BLUE	LIGHT BLUE/WHITE								PURPLE

TABLE OF CONTENTS

CFMOTO WARRANTY COVERAGE.....	2
TERMS & CONDITIONS.....	2
CFMOTO EMISSIONS LIMITED WARRANTY.....	7
DEALER INSPECTION REGISTRATION.....	9
CHANGE OF OWNERSHIP REGISTRATION.....	11

WARRANTY ACTIVATION:

- Dealer & Customer Information
- Dealer Checklist
- Customer Checklist



CFMOTO WARRANTY COVERAGE

Dear Customer,

Thank you for purchasing a CFMOTO ATV, UTV, SSV, Motorcycle, or Scooter. If any component on your vehicle is found to be defective in materials or workmanship within the terms and conditions of this Limited Warranty, the defective component will be repaired or replaced (at the option of CFMOTO) without charge for parts and/or labor at any authorized dealer located within the United States. The CFMOTO Limited Warranty is subject to the following terms and conditions:

TERMS & CONDITIONS

- 1. **WARRANTY DURATION.** The duration of the Warranty period is one (1) year from the date of the new vehicle purchase from an authorized CFMOTO POWERSPORTS, Inc., Dealer. The warranty coverage is invoked from the purchase and use of CFMOTO vehicles only within the continental United States. During the warranty period, CFMOTO POWERSPORTS, Inc. will cover parts and labor costs incurred by an authorized CFMOTO POWERSPORTS, Inc., Dealer arising from a defect in material and/or workmanship of a CFMOTO vehicle. Any vehicles used for commercial purposes will have their warranty period reduced to six (6) months. If CFMOTO POWERSPORTS, Inc., covers a full engine replacement or a complete vehicle replacement under this warranty, the warranty period does not get extended and remains the same as the original purchase date of the vehicle at issue.
- 2. **WARRANTY LIMITATIONS.** CFMOTO POWERSPORTS, Inc., provides warranty coverage for one (1) year on all parts and labor for all of its new CFMOTO Motorcycles, Scooters, ATVs, UTVs, and SSVs. However, the following coverage, exceptions, and limitations apply to all CFMOTO vehicles:
- 3. **EXCLUSIONS FROM WARRANTY COVERAGE.** Any Damage resulting from the following acts or circum-

- a. **A 30-DAY WARRANTY** coverage period applies to all new CFMOTO vehicles in relation to the vehicles':
- Battery
 - Spark Plugs
 - Air Filters
 - Oil and Fuel Filters
- b. **A 90-DAY WARRANTY** coverage period applies to all new CFMOTO vehicles in relation to the vehicles':
- Drive Belts
 - Gear Shift, CVT, and Wet Clutches
 - Throttle, Brake, and Clutch Cables
 - Front/Rear Rims
 - Front/Rear Tires
 - Front/Rear Brake Pads or Shoes
 - Front/Rear Brake Discs or Drums
 - Wheel or Steering Stem Bearings and Seals
 - Rubber Parts/Engine Mounts/Grips/Boots
 - Brake or Clutch Levers
 - Floor Boards or Pegs
 - ATV/UTV/SSV Winch
 - Light Bulbs/Fuses
 - Body Plastics and Cosmetic Defects

stances is not covered by the CFMOTO POWERSPORTS, Inc., Limited Warranty:

- Fire
- Collision
- Theft
- Unavoidable natural disasters
- Improper storage or transportation
- Failure or negligence in the performance of periodic vehicle maintenance
- Improper or negligent use or operation
- Unauthorized repair or adjustment
- Unauthorized modifications or performance upgrades
- Use of vehicle as a rental vehicle
- Use of vehicle in competitive or racing events

4. VEHICLE CARE AND MAINTENANCE. The vehicle's owner must properly use, maintain, and care for the vehicle as outlined in the CFMOTO POWERSPORTS, Inc., Owner's Manual. Any warranty repairs must be performed exclusively by CFMOTO POWERSPORTS, Inc., authorized Dealers. Any warranty work performed by anyone other than an authorized CFMOTO Dealer will not be covered under the CFMOTO POWERSPORTS, Inc., Limited Warranty policy.

5. TRANSFER OR CONTINUATION OF WARRANTY. This warranty is transferable only under the following conditions:

- Transfer information must be provided to an authorized CFMOTO POWERSPORTS, Inc., dealer, who will then forward the information to CFMOTO POWERSPORTS, Inc.;
- The complete model and serial number as shown on the original warranty document must be provided;
- The name and address of the existing and new owners must be provided;
- The original delivery date of the vehicle must be provided;
- The new owner must indicate in writing that he/she has received and read the vehicle's Owner's Manual and the CFMOTO POWERSPORTS, Inc. Warranty Policy.

6. **WARRANTY REGISTRATION.** The Dealer must register the vehicle online and provide the completed registration form to CFMOTO POWERSPORTS, Inc., within seven (7) days of completing the sale of the vehicle. Please note that NO warranty claims will be processed unless the product warranty online registration form is completed and the form is received by CFMOTO POWERSPORTS, Inc., from the Dealer.
7. **CUSTOMER ASSISTANCE.** Any questions regarding your CFMOTO vehicle or related products should be directed to an authorized CFMOTO dealer. However, if a dealer is not available to answer customer concerns, or address a technical issue with a CFMOTO vehicle or product, CFMOTO POWERSPORTS, Inc., customer representatives can be contacted directly at (763) 398-2690 or by e-mail at info@cfmoto-us.com.
8. **DEALER RESPONSIBILITIES.** A CFMOTO authorized Dealer must perform warranty coverage repairs at no charge to the customer, even if they are not the dealer that sold the CFMOTO vehicle to the customer and must use CFMOTO OEM parts for all warranty repairs. All vehicles sold by the dealer must be inspected and tested by the dealer to ensure proper performance and operation prior to delivery to the customer. No vehicles may be delivered to a customer without first passing a dealer inspection and an operational test.
9. **COMMERCIAL USE.** The duration of the warranty for commercial use shall be limited to a period of six (6) months instead of one year for recreational use. All other conditions and limitations shall apply.
10. **TIRES PROVIDED AS ORIGINAL EQUIPMENT.** Other than provided herein, vehicle tires supplied as original equipment are warranted separately by the individual tire manufacturer or its representatives.
11. **DISCLAIMER.** NO EXPRESS WARRANTY IS PROVIDED BY CFMOTO POWERSPORTS, INC. WITH RESPECT TO CFMOTO VEHICLES EXCEPT AS SPECIFICALLY SET FORTH HEREIN. ANY IMPLIED WARRANTY, WARRANTY OF MERCHANTABILITY, WARRANTY OF FITNESS FOR A PARTICULAR PURPOSE, AND ALL IMPLIED WARRANTIES ARISING FROM A COURSE OF DEALING, USAGE OF TRADE, BY STATUTE OR OTHERWISE, ARE HEREBY STRICTLY LIMITED TO THE TERMS OF THIS

WRITTEN LIMITED WARRANTY.

12. INTEGRATION. This limited warranty supersedes any and all oral, express, or written warranties, statements, or undertakings that may previously have been made, and contains the entire agreement of the parties with respect to the warranty of CFMOTO vehicles. Any and all warranties not contained in this Agreement are specifically excluded. This warranty extends to each original (and subsequent) owner of any CFMOTO ATV, UTV, SSV, Motorcycle, or Scooter for the term of the original warranty period. This limited warranty shall be the sole and exclusive remedy available to the customer with respect to the covered CFMOTO vehicle. In the event of any alleged breach of any warranty or any legal action brought by the customer based on alleged negligence or other conduct by CFMOTO POWERSPORTS, Inc., or its related parties, the customer's sole and exclusive remedy will be repair or replacement of defective components as stated above, unless otherwise provided by law. Some states do not allow limitations on how long an implied warranty lasts, so the above limitations may not apply if they are deemed inconsistent with the controlling state law.

CFMOTO EMISSIONS LIMITED WARRANTY

This emissions limited warranty is in addition to the CFMOTO standard limited warranty for your vehicle and is likewise subject to the terms and conditions set forth above. CFMOTO Powersports Inc., warrants that at the time of sale, your USEPA and CARB certified vehicle is designed, built and equipped so it conforms to applicable U.S. Environmental Protection Agency emission regulations. CFMOTO Powersports Inc., also warrants that your USEPA certified vehicle is free from defects in materials and workmanship that may keep it from meeting U.S. Environmental Protection Agency emission regulations.

The emissions limited warranty period initiates from the date of the new vehicle purchase from an authorized CFMOTO POWERSPORTS, Inc., Dealer and continues for a period of thirty-six (36) calendar months from the date of purchase. This emissions limited warranty covers components whose failure increases the vehicle's regulated pollutant, including components listed in 40 CFR part 1068, Appendix I, and it covers components of systems whose only purpose is to control emissions. The emission-related warranty covers these components even if another company produces the component. Your emission-related warranty does not cover components whose failure would not increase an engine's emissions of any regulated pollutant. Where a warrantable condition exists, a CFMOTO authorized Dealer will repair your vehicle at no cost to you, including diagnosis, parts, and labor.

TAMPERING WITH THE NOISE CONTROL SYSTEM IS PROHIBITED

Owners are warned that Federal law prohibits:

- The removal or rendering inoperative by any person other than for the purpose of maintenance, repair, or replacement of any device or element of design incorporated into any new CFMOTO vehicle for the purpose of noise control, prior to its sale or delivery to the customer, or while it is in use by the customer

after purchase;

- The use of the vehicle after such devices or elements of design have been removed or rendered inoperative by any person is prohibited.

Acts which are likely to constitute tampering are:

- Removal of or tampering with the mufflers, baffles, or header pipes, or any other component which conduct exhaust gases.
- Removal of, or puncturing of, any part of the air intake system.
- Replacement of any parts of the exhaust or air intake system with any parts other than OEM parts specified by CFMOTO.

WARNING: CFMOTO vehicles should be checked for part repair or replacement if the vehicle noise increases significantly through use by the customer. Failure to do so may subject the owner of the vehicle to penalties or fines under state and local ordinances.

USA

INSPECTION REGISTRATION CARD	SERVICING MUST BE CARRIED OUT ACCORDING TO THE SCHEDULE DEFINED IN THE PRODUCTS USE AND MAINTENANCE BOOKLET					
INSPECTION NUMBER	1	2	3	4	5	6
Date						
Km/Miles						
Stamp and Signature of the Dealer						

<p align="center">INSPECTION REGISTRATION CARD</p>	<p align="center">SERVICING MUST BE CARRIED OUT ACCORDING TO THE SCHEDULE DEFINED IN THE PRODUCTS USE AND MAINTENANCE BOOKLET</p>					
<p>INSPECTION NUMBER</p>	7	8	9	10	11	12
<p>Date</p>						
<p>Km/Miles</p>						
<p>Stamp and Signature of the Dealer</p>						



CHANGE OF OWNERSHIP

If you sell the product, any valid remainder of the warranty can be transferred to the new Owner.
Please record the details of the exchange below and inform an Authorized **CFMOTO Dealer**.

REGISTRATION OF CHANGE OF OWNERSHIP	2nd OWNER	3rd OWNER	4th OWNER
OWNER'S NAME			
ADDRESS			
TOWN/CITY			
STATE-ZIP			
TELEPHONE			
E-MAIL			
DATE OF PURCHASE			
ODOMETER READING			
NEW OWNER SIGNATURE			

IMPORTANT:

If the details contained in the Change of Ownership Application form do not include the required details or are inaccurate, we reserve the right to investigate the actual ownership of the product and its service history and possibly refuse the application if the requirements for transfer have not been fulfilled.

Recommended Periodic Maintenance Chart (4 - Wheeler)

ITEM		MAINTENANCE INTERVAL (WHICHEVER COMES FIRST)			REMARKS
		HOUR	CALENDAR	MILES	
■	Steering	—	Pre-Ride	—	Make adjustments as needed. See Pre-Ride Checklist in Owner's Manual
▶	Front Suspension	—	Pre-Ride	—	
▶	Rear Suspension	—	Pre-Ride	—	
	Tires	—	Pre-Ride	—	
▶	Brake Fluid	—	Pre-Ride	—	
▶	Brake Level and Lever Travel	—	Pre-Ride	—	
	Brake System	—	Pre-Ride	—	
	Wheels/fasteners	—	Pre-Ride	—	
	Frame Fasteners	—	Pre-Ride	—	
▶	Engine Oil level	—	Pre-Ride	—	
▶	Air Inlet, Air Filter				Inspect and clean if necessary
▶	Air box Sediment Tube				Drain deposits when visible
	Coolant	50 H	Daily	1500	Check level daily / change coolant Every 2 years or 6000km/200H, but initial check should be done after 20 H or 750 km.

	Headlight / tail light		Daily		Check operation; apply dielectric grease if replacing
	Air filter element	50 H	—	1500	Inspect. Clean every 1000 km or 100 hours. Replace initial replacement should be done after 750 km or 20 H.
	CVT outlet pipe		Weekly		Drain water as needed, check often if operating in wet conditions
	Brake pad wear	10 H	Monthly	100	Inspect periodically
	Battery	20 H	Monthly	200	Check terminals; clean; test
▶	Front gear case oil	25 H	Monthly	250	Inspect level; change yearly
▶	Rear gear case oil	25 H	Monthly	250	Inspect level; change yearly
▶	Transmission oil	25 H	Monthly	250	Inspect level; change yearly
▶	Engine oil change (Break-in)	20 H		250	Change
▶	General lubrication	50 H	3 M	500	Lubricate all fittings, pivots, cables, etc.
	Steering knuckle	50 H	6 M	500	lubricate
■	Steering handlebar	50 H	6 M	500	lubricate
▶	Front suspension	50 H	6 M	500	lubricate
	Rear suspension	50 H	6 M	500	lubricate
	Gearshift	28 H	1 M	500	Inspect, lubricate, adjust

■	Throttle cable/Switch	50 H	6 M	500	Inspect; adjust; lubricate; replace if necessary
■	Drive belt, CVT	50 H	6 M	1500	Inspect; adjust; replace if necessary. Replace for every 3000 km
	Cooling system	50 H	6 M	500	Inspect coolant strength seasonally; pressure test system yearly
▶	Engine oil change	100 H	Year	3000	Perform a break-in oil change at 25 hours/750 km
▶	Fuel hose	100 H	Year	1000	Inspect routing, condition, Replace high pressure fuel hose every 4 years
■	Valve clearance	100 H	Year	3000	Inspect, Adjust, Initial: 750 km, or 20 H
■	Fuel system	100 H	Year	1000	Inspect cap of fuel tank, fuel pump and fuel relay.
■	Oil filter	100 H	Year	3000	Initial change: 750 km or 20 H
▶	Radiator	200 H	24 M	3000	Inspect; clean external surfaces
▶	Cooling hoses	100 H	Year	1000	Inspect. Initial: 300 km or 10 H
▶	Engine mounts	100 H	Year	3000	Inspect. Initial: 300 km or 10 H
	Exhaust pipe and muffler	100 H	Year	1000	Inspect
	Ignition coil	100 H	Year	1000	Inspect and replace as needed
■	ECU	100 H	Year	1000	Inspect and replace as needed

	Wirings and cables	100 H	Year	1000	Inspect for wear, routing, security; apply dielectric grease to connectors subjected to water, mud, etc.
■	Clutches(drive and driven pulley)	100 H	Year	3000	Inspect; clean; replace worn parts
	Wheel bearings	100 H	Year	1600	Inspect and replace as necessary
	Brake fluid	100 H	Year	2000	Change every two years
	Spark plug	100 H	Year	3000	Initial: 750 km or 20 H. Replace every 6000 km
	Idle condition				Inspect every component. 1300 ± 100 r/min
■	Toe adjustment				Inspect periodically; adjust when parts are replaced
	Auxiliary brake				Inspect daily; adjust as needed
■	Headlight aim				Adjust as needed

(typical) (For specific vehicle information, refer to the owners manual)

- ▶ Perform these procedures more often for vehicles subjected to severe use.
- Have an authorized dealer perform these services.



IMPORT BY: CFMOTO POWERSPORTS, INC.

3555 Holly Lane N, Suit #30, Plymouth, MN 55447, USA

Toll free: (888) 8-CFMOTO (823-6686) Tel: (1) 763 398 2690 Fax: (1) 763 398 2695 Website: www.cfmoto-us.com

US1202