

ZFORCE SERIES

2017-2018

ZFORCE 550EX

ZFORCE 800EX

ZFORCE 1000

ZFORCE 500TRAIL

ZFORCE 800TRAIL

READ THIS MANUAL CAREFULLY

It contains important safety information.

This ROV should not be ridden by anyone under 16 years of age. Passenger under 12 are prohibited.



 **CFMOTO**
EXPERIENCE MORE TOGETHER

Table of Contents
TABLE OF CONTENTS

TABLE OF CONTENTS.....	1
Foreword.....	1
Welcome.....	1
EVAP System (Evaporative Emission Control System)	2
Catalytic Converter	2
Signal Words	3
Introduction	7
Vehicle Identification Numbers	8
ZFORCE 1000 Specifications.....	9
ZFORCE 800 EX Specifications	16
ZFORCE 800 Trail Specifications.....	23
ZFORCE 500 EX Specifications	30
ZFORCE 500 Trail Specifications.....	37
Operator Safety	44
General Safety Precautions.....	44
Owner Responsibilities	47
Safety Labels, Locations and Warnings	52
Potential Hazard Warnings.....	57

Table of Contents

Controls and Features	77
Primary Controls	77
Secondary Controls	80
Vehicle Features.....	86
Operating Your Vehicle	97
Break-In Period.....	97
Pre-Ride Inspection	99
Throttle.....	100
Foot Brake	100
Starting the Engine	101
Shifting the Transmission	102
Safe Operation - Driving Safely	105
Responsibilities of the operator	105
Practice Exercises	109
Operating Your Vehicle	112
Hauling and Towing Loads	117
Maintenance	122
Severe Use Definition	123
General Recommended Lubrication.....	123

Table of Contents

Periodic Maintenance Schedule and Icon Key	125
Inspection and Service Record.....	132
Maintenance Procedures.....	134
Cleaning and Storage	173
Washing the vehicle.....	173
Waxing the vehicle.....	173
Perform repairs	174
Check the tires	174
Oil and filter.....	174
Air filter/ Air box	174
Check fluid levels.....	175
Stabilize the fuel	175
Battery storage	175
Lubricate	175
'Fog' the engine	176
Storage area and covering	177
Transporting the vehicle	177
Vehicle Issue Diagnosis	178
Engine doesn't turn over.....	178

Table of Contents

Engine pings or knocks	178
Engine stops or loses power	179
Engine turns over, Fails to start.....	179
Engine backfires	181
Engine runs irregularly, stalls or misfires.....	181
EFI Malfunction Indicator Light	183
EPS Malfunction Indicator Light	184
Electronic Power Steering (EPS) fault diagnosis and solution	186
Change of Ownership	187
CFMOTO Limited Warranty	188
WARRANTY TERMS & CONDITIONS	188
U.S.A. EPA and CARB Emissions Control Limited Warranty.....	193
Noise Control System and Tampering.....	197

FOREWORD

Foreword

Welcome

Thank you for purchasing a CFMOTO vehicle, and welcome to our world-wide family of CFMOTO enthusiasts. Be sure to visit us online at www.cfmoto-usa.com for the latest news, new product introductions, upcoming events, career opportunities, and more.

CFMOTO develops, manufactures, markets and delivers the world's most reliable and cost-effective all-terrain vehicles, motorcycles and scooters, utility vehicles, boat and power sports engines. Founded in 1989 and teaming up with more than 1200 companions, CFMOTO has developed 98 vehicle models and 51 engine models, which are distributed in over 70 countries and regions. CFMOTO is edging into the advanced ranks in the world in the power sports industry, and aims to supply superior products to dealers and fans globally.

For safe and enjoyable operation of your vehicle, be sure to follow the instructions and recommendations in this owner's manual. Your manual contains instructions for minor maintenance. Information about major repairs is outlined in the CFMOTO Service Manual. Your CFMOTO dealer knows your vehicle best and is interested in your total satisfaction. Be sure to return to your dealership for all of your service needs during, and after, the warranty period.

FOREWORD

WARNING

The engine exhaust from this product contains chemicals known to the State of California to cause cancer, birth defects or other reproductive harm.

EVAP System (Evaporative Emission Control System)

Do not modify the EVAP system. Modification is a violation of EPA regulations. Ensure that all the hoses are not clogged or kinked, otherwise it could damage the fuel pump or distort the fuel tank.

Catalytic Converter

CAUTION - Please respect the following instructions to protect your catalytic converter:

- Use only unleaded gasoline. Even if the gasoline contains a little lead, it could damage the reactive metals contained in the catalytic converter and disable it.
- Never add rust preventive oil and engine oil into muffler, otherwise it could disable the catalytic converter.

NOTE:

Some features described within this manual may not apply to models sold in the U.S. All descriptions and directions given are from the operator's perspective when seated in the vehicle.

FOREWORD

Signal Words

A signal word calls attention to a safety message or messages, a property damage message or messages, and designates a degree or level of hazard seriousness. The standard signal words in this manual are WARNING, CAUTION and NOTE or NOTICE.

The following signal words and symbols appear throughout this manual and on your vehicle. Your safety is involved when these words and symbols are used. Become familiar with their meanings before reading the manual:

WARNING

This safety alert and icon indicates a potential hazard that may result in serious injury or death.

CAUTION

This safety alert and icon indicates a potential hazard that may result in minor or moderate personal injury and/or damage to the vehicle.

CAUTION

This safety alert without an icon indicates a situation that may result in damage to the vehicle.

NOTE or NOTICE

A note or notice will alert you to important information or instructions

FOREWORD



NEVER:

- Operate without proper training or instruction.
- Operate on public roads. A collision can occur with another vehicle.
- Operate on paved roads. Pavement may seriously affect handling and control.
- Operate at speeds too fast for your skill, conditions, or the terrain.
- Carry multiple passengers, SSVs are designed for a single passenger only.
- Use ALCOHOL or DRUGS before or while driving this vehicle.

ALWAYS:

- Avoid paved surfaces, which may adversely affect the handling and control.
- Use proper driving techniques to avoid vehicle overturn on hills, rough terrain, and when turning.
- Wear eye protection, helmet and protective clothing.

FOREWORD
READ THE OWNER'S MANUAL

FOLLOW ALL INSTRUCTIONS AND WARNINGS

 WARNING

Read, understand, and follow all of the instructions and safety precautions in this manual and on all product labels. Failure to follow the safety precautions could result in serious injury or death.

 WARNING

The engine exhaust gas from this product contains CO, which is deadly gas and could cause headaches, giddy, or lose consciousness, even death.

INTRODUCTION

Introduction

Thank you for purchasing a CFMOTO vehicle, and welcome to our worldwide family of CFMOTO owners. We proudly produce an exciting line of utility and recreational products:

- All-Terrain Vehicles (ATV).
- Utility (UTV) and Side-by-Side (SSV) Vehicles (farm, patrol, forest protecting and hunting).
- Motorcycles and Scooters.

CFMOTO, a company which specializes in production of liquid-cooled engines, is the top-level supplier in China. Compared to same displacement air-cooled engines, engine cooling is more effective, oil temperature is more stable, the engine is more powerful with lower fuel consumption, and has a longer working life.

For safe and enjoyable operation of your vehicle, be sure to follow the instructions and recommendations in this owner's manual. Your manual contains instructions for minor maintenance. Information about major repairs are outlined in the CFMOTO service manual, and should be performed only by a CFMOTO service dealer and technician. Your CFMOTO dealer knows your vehicle best and is interested in your total satisfaction. Be sure to return to your dealership for all of your service.

Due to constant improvements in the design and quality of production components, some minor discrepancies may result between the actual vehicle and the information presented in this publication. Depictions and/or procedures in this publication are intended for reference use only. The most current version of this manual can be found online at www.cfmotousa.com

SPECIFICATIONS

ZFORCE 1000 Specifications

Item	ZFORCE 1000 Specification
	CF1000US-2
Overall Length	112.9 in. (2870 mm)
Overall Width	59.4 in (1510 mm)
Overall Height	72.6 in. (1845 mm)
Wheel Base	80.3 in. (2040 mm)
Minimum ground clearance	12.2 in. (310 mm)
Min. turning radius	374 in. (9500 mm)
Basic weight:	1344 lb. (610 kg)
Rear cargo box weight capacity	220.3 lb. (100 kg)
Maximum vehicle load allowed	694 lb.(315 kg)
Recommended towing capacities: Tongue weight Trailer and Cargo weight	110 lb. (50 kg) 550 lb. (250 kg)
Engine model and type	2V91Y
Type	V-twin, Liquid-cooled/4-stroke, 8 valves, SOHC

SPECIFICATIONS

Item	ZFORCE 1000 Specification
	CF1000US-2
Bore x Stroke	3.5 x 2.42 in (91 x 74 mm) x 2
Displacement	962.6 cc
Compression ratio	10.6:1
Starting type	Electric start
Lubrication type	Splash /pressure feed
Engine coolant: Type Capacity Mix Ratio	Commercially available – Safe for aluminum engines 3.1 qt. (3.0 L) 50% coolant / 50% distilled water
Engine oil: Type Engine oil volume: Capacity change / oil filter	SAE15W-40/SG – JASO certified for wet clutch (10W-40 acceptable alternative/cold weather) 3.06 qt. (2.5L)
Transmission oil: Type Periodic oil change	SAE75W/90 GL-5 (0.6L)

SPECIFICATIONS

Item	ZFORCE 1000 Specification
	CF1000US-2
Rear differential oil: Type Volume Periodic oil change Capacity	SAE75W/90 GL-5 8.4 oz. (250ml) 10.1 oz. (300ml)
Front differential oil: Type Volume Periodic oil change Capacity	SAE75W/90 GL-5 9.4 oz. (280ml) 11.1 oz. (330ml)
Air filter	Paper filter element with foam pre-filter
Fuel type Fuel tank capacity Fuel reserve amount at fuel gauge 'flash' (approximate)	89 Octane minimum unleaded gasoline 7.1 gallons (27 L) 0.9 gallons. (3.5 L)
Throttle Body type:	OJY0-173000

SPECIFICATIONS

Item		ZFORCE 1000 Specification	
		CF1000US-2	
Spark plug: type Spark plug gap		DCPR8E (NGK) .035~.045 in. (0.8~0.9 mm)	
Transmission	Transmission		CVT + Gear shift
	Gear shift/order		Manual / L – H – N – R – P
	CVT ratio		0.70~2.88
	Gear ratio	Low Gear	43/17=2.529
		High Gear	32/28=1.143
Reverse		29/13=2.231	
Chassis Frame	Steel tube		
Tires: Type Front Rear		Tubeless AT 27×9.0-14 60L or AT 27×9.0-14 61L AT 27×11.0-14 66L or AT 27×11.0-14 70L	

SPECIFICATIONS

Item	ZFORCE 1000 Specification
	CF1000US-2
Tire pressure:	
Front	10.1 psi (70 kPa)
Rear	14.5 psi (100 kPa)
Brake system:	Front axles: Double-disc / Rear axles: Double-disc
Foot brake Type / Operation	Foot Operated
	Four wheel disc
Parking brake Type / Operation	Operated by hand
	Rear discs only
Brake Fluid Type	DOT 4
Suspension:	
Front suspension	Double A-arm independent
Rear suspension	Double A-arm independent

SPECIFICATIONS

Item	ZFORCE 1000 Specification
	CF1000US-2
Shock absorber: Front shock absorber Rear shock absorber	Coil spring/Gas and Oil dampened Coil spring/Gas and Oil dampened
Wheel travel: Front wheel travel Rear wheel travel	6.3 in. (160 mm) 7.8 in. (200 mm)
Electrical system: Ignition Charging Battery	Electronic Rectified A/C 460 Watt @ 5000 rpm 12Vdc / 30 Amp Hr

SPECIFICATIONS

Item	ZFORCE 1000 Specification
	CF1000US-2
Light system: Head lamp, low beam Head lamp, high beam Front position light Tail light/Brake light License plate light	H3 12V 55Wx2 H7 12V 55Wx2 LED LED Incandescent - 5Wx1
Dashboard	LED and LCD -- Non-serviceable
Fuses	Main – 40 Amp x 1 EPS – 30 Amp x 1 Auxiliary - 10 Amp x 2 Auxiliary – 15 Amp x 3 ECU – 5 Amp x 1

SPECIFICATIONS

ZFORCE 800 EX Specifications

Item	ZFORCE 800 EX Specification
	CF800
Overall Length	112.9 in. (2870 mm)
Overall Width	59.4 in (1510 mm)
Overall Height	72.0 in. (1830 mm)
Wheel Base	80.3 in. (2040 mm)
Minimum ground clearance	12.2 in. (310 mm)
Min. turning radius	374 in. (9500 mm)
Basic weight:	1267 lb. (575 kg)
Rear cargo box weight capacity	330 lb. (150 kg)
Maximum vehicle load allowed	694 lb.(315 kg)
Recommended towing capacities: Tongue weight Trailer and Cargo weight	110 lb. (50 kg) 550 lb. (250 kg)
Engine model and type	2V91W
Type	V-twin, Liquid-cooled/4-stroke, 8 valves, SOHC

SPECIFICATIONS

Item	ZFORCE 800 EX Specification
	CF800
Bore x Stroke	3.5 x 2.42 in (91 x 61.5 mm) x 2
Displacement	800 cc
Compression ratio	10.3:1
Starting type	Electric start
Lubrication type	Splash /pressure feed
Engine coolant: Type Capacity Mix Ratio	Commercially available – Safe for aluminum engines 3.1 qt. (3.0 L) 50% coolant / 50% distilled water
Engine oil: Type Engine oil volume: Capacity change / oil filter	SAE15W-40/SG – JASO certified for wet clutch (10W-40 acceptable alternative/cold weather) 3.06 qt. (2.9L)

SPECIFICATIONS

Item	ZFORCE 800 EX Specification
	CF800
Rear differential oil: Type Volume Periodic oil change Capacity	SAE80W/90 GL-4 8.4 oz. (250ml) 10.1 oz. (300ml)
Front differential oil: Type Volume Periodic oil change Capacity	SAE80W/90 GL-4 9.4 oz. (280ml) 11.1 oz. (330ml)
Air filter	Paper filter element with foam pre-filter
Fuel type Fuel tank capacity Fuel reserve amount at fuel gauge 'flash' (approximate)	89 Octane minimum unleaded gasoline 6.9 gallons (26 L) 0.9 gallons. (3.5 L)
Throttle Body type:	0800-173000-1000

SPECIFICATIONS

Item		ZFORCE 800 EX Specification	
		CF800	
Spark plug: type Spark plug gap		DCPR8E (NGK) .035~.045 in. (0.8~0.9 mm)	
Transmission	Transmission		CVT + Gear shift
	Gear shift/order		Manual / L – H – N – R – P
	CVT ratio		0.70~2.88
	Gear ratio	Low Gear	43/17=2.529
		High Gear	32/28=1.143
Reverse		29/13=2.231	
Chassis Frame	Steel tube		
Tires: Type Front Rear		Tubeless AT 26×9.0-14 64K or AT 26×9.0-12 65K AT 26×11.0-14 71K or AT 26×11.0-12 72K	

SPECIFICATIONS

Item	ZFORCE 800 EX Specification
	CF800
Tire pressure:	
Front	10.1 psi (70 kPa)
Rear	14.5 psi (100 kPa)
Brake system:	Front axles: Double-disc / Rear axles: Double-disc
Foot brake Type / Operation	Foot Operated
	Four wheel disc
Parking brake Type / Operation	Operated by hand
	Rear discs only
Brake Fluid Type	DOT 4
Suspension:	
Front suspension	Double A-arm independent
Rear suspension	Double A-arm independent

SPECIFICATIONS

Item	ZFORCE 800 EX Specification
	CF800
Shock absorber: Front shock absorber Rear shock absorber	Coil spring/Gas and Oil dampened Coil spring/Gas and Oil dampened
Wheel travel: Front wheel travel Rear wheel travel	6.3 in. (160 mm) 7.8 in. (200 mm)
Electrical system: Ignition Charging Battery	Electronic Rectified A/C 460 Watt @ 5000 rpm 12Vdc / 30 Amp Hr

SPECIFICATIONS

Item	ZFORCE 800 EX Specification
	CF800
Light system: Head lamp, low beam Head lamp, high beam Front position light Tail light/Brake light License plate light	H3 12V 55Wx2 H7 12V 55Wx2 LED LED Incandescent - 5Wx1
Dashboard	LED and LCD -- Non-serviceable
Fuses	Main – 40 Amp x 1 EPS – 30 Amp x 1 Auxiliary - 10 Amp x 2 Auxiliary – 15 Amp x 3 ECU – 5 Amp x 1

SPECIFICATIONS

ZFORCE 800 Trail Specifications

Item	ZFORCE 800 Trail Specification
	CF800US-A
Overall Length	112.9 in. (2870 mm)
Overall Width	50.0 in (1270 mm)
Overall Height	70.5 in. (1790 mm)
Wheel Base	80.3 in. (2040 mm)
Minimum ground clearance	12.2 in. (310 mm)
Min. turning radius	374 in. (9500 mm)
Basic dry weight:	1267 lb. (575kg)
Rear cargo box weight capacity	330 lb. (150 kg)
Maximum vehicle load allowed	694 lb.(315 kg)
Recommended towing capacities: Tongue weight Trailer and Cargo weight	110 lb. (50 kg) 550 lb. (250 kg)
Engine model and type	2V91W
Type	V-twin, Liquid-cooled/4-stroke, 8 valves, SOHC

SPECIFICATIONS

Item	ZFORCE 800 Trail Specification
	CF800US-A
Bore x Stroke	3.5 x 2.42 in (91 x 61.5 mm) x 2
Displacement	800 cc
Compression ratio	10.3:1
Starting type	Electric start
Lubrication type	Splash /pressure feed
Engine coolant: Type Capacity Mix Ratio	Commercially available – Safe for aluminum engines 3.1 qt. (3.0 L) 50% coolant / 50% distilled water
Engine oil: Type Engine oil volume: Capacity change / oil filter	SAE15W-40/SG – JASO certified for wet clutch (10W-40 acceptable alternative/cold weather) 3.06 qt. (2.9L)

SPECIFICATIONS

Item	ZFORCE 800 Trail Specification
	CF800US-A
Rear differential oil: Type Volume Periodic oil change Capacity	SAE80W/90 GL-4 8.4 oz. (250ml) 10.1 oz. (300ml)
Front differential oil: Type Volume Periodic oil change Capacity	SAE80W/90 GL-4 9.4 oz. (280ml) 11.1 oz. (330ml)
Air filter	Paper filter element with foam pre-filter
Fuel type Fuel tank capacity Fuel reserve amount at fuel gauge 'flash' (approximate)	89 Octane minimum unleaded gasoline 7.1 gallons (27 L) 0.9 gallons. (3.5 L)
Throttle Body type:	0800-173000-1000

SPECIFICATIONS

Item		ZFORCE 800 Trail Specification	
		CF800US-A	
Spark plug: type Spark plug gap		DCPR8E (NGK) .035~.045 in. (0.8~0.9 mm)	
Transmission	Transmission		CVT + Gear shift
	Gear shift/order		Manual / L – H – N – R – P
	CVT ratio		0.70~2.88
	Gear ratio	Low Gear	43/17=2.529
		High Gear	32/28=1.143
Reverse		29/13=2.231	
Chassis Frame		Steel tube	
Tires: Type Front Rear		Tubeless AT 26x9.0-14 AT 26x11.0-14	

SPECIFICATIONS

Item	ZFORCE 800 Trail Specification
	CF800US-A
Tire pressure: Front Rear	10.1 psi (70 kPa) 14.5 psi (100 kPa)
Brake system:	Front axles: Double-disc / Rear axles: Double-disc
Foot brake Type / Operation	Foot Operated
Parking brake Type / Operation	Four wheel disc Operated by hand Rear discs only
Brake Fluid Type	DOT 4
Suspension: Front suspension Rear suspension	Double A-arm independent Double A-arm independent

SPECIFICATIONS

Item	ZFORCE 800 Trail Specification
	CF800US-A
Shock absorber: Front shock absorber Rear shock absorber	Coil spring/Gas and Oil dampened Coil spring/Gas and Oil dampened
Wheel travel: Front wheel travel Rear wheel travel	6.3 in. (160 mm) 7.8 in. (200 mm)
Electrical system: Ignition Charging Battery	Electronic Rectified A/C 460 Watt @ 5000 rpm 12Vdc / 30 Amp Hr

SPECIFICATIONS

Item	ZFORCE 800 Trail Specification
	CF800US-A
Light system: Head lamp, low beam Head lamp, high beam Front position light Tail light/Brake light License plate light	H3 12V 55Wx2 H7 12V 55Wx2 LED LED Incandescent - 5Wx1
Dashboard	LED and LCD -- Non-serviceable
Fuses	Main – 40 Amp x 1 EPS – 30 Amp x 1 Auxiliary - 10 Amp x 2 Auxiliary – 15 Amp x 3 ECU – 5 Amp x 1

SPECIFICATIONS

ZFORCE 500 EX Specifications

Item	ZFORCE 500 EX Specification
	CF500US-EX
Overall Length	112.9 in. (2870 mm)
Overall Width	59.4 in (1510 mm)
Overall Height	70.5 in. (1790 mm)
Wheel Base	80.3 in. (2040 mm)
Minimum ground clearance	11.3 in. (287 mm)
Min. turning radius	374 in. (9500 mm)
Basic weight:	1272 lb. (577 kg)
Rear cargo box weight capacity	220.3 lb. (100 kg)
Maximum vehicle load allowed	573.2 lb.(260 kg)
Recommended towing capacities: Tongue weight Trailer and Cargo weight	110 lb. (50 kg) 334 lb. (125 kg)
Engine model and type	191R
Type	Liquid-cooled/4-stroke, 4 valves, SOHC

SPECIFICATIONS

Item	ZFORCE 500 EX Specification
	CF500US-EX
Bore x Stroke	3.5 x 3.0 in (91 x 76.2 mm)
Displacement	495 cc
Compression ratio	10.3:1
Starting type	Electric start
Lubrication type	Splash /pressure feed
Engine coolant: Type Capacity Mix Ratio	Commercially available – Safe for aluminum engines 3.1 qt. (3.0 L) 50% coolant / 50% distilled water
Engine oil: Type Engine oil volume: Capacity change / oil filter	SAE15W-40/SG (10W-40 acceptable alternative/cold weather) 2.95 qt. (2.8L)

SPECIFICATIONS

Item	ZFORCE 500 EX Specification
	CF500US-EX
Rear differential oil: Type Volume: Periodic oil change Capacity	SAE80W/90 GL-4 8.4 oz. (250ml) 10.1 oz. (300ml)
Front differential oil: Type Volume: Periodic oil change Capacity	SAE80W/90 GL-4 9.4 oz. (280ml) 11.1 oz. (330ml)
Air filter	Paper filter element with foam pre-filter
Fuel type Fuel tank capacity Fuel reserve amount at fuel gauge 'flash' (approximate)	89 Octane minimum unleaded gasoline 7.1 gallons (27 L) 0.9 gallons. (3.5 L)
Throttle Body type:	0GRB-173000-30000

SPECIFICATIONS

Item		ZFORCE 500 EX Specification	
		CF500US-EX	
Spark plug: type Spark plug gap		DCPR8E (NGK) .035~.045 in. (0.8~0.9 mm)	
Transmission	Transmission		CVT + Gear shift
	Gear shift/order		Manual / L – H – N – R – P
	CVT ratio		0.67~3.02
	Gear ratio	Low Gear	38/15=2.533
		High Gear	27/20=1.350
Reverse		29/14=2.071	
Chassis Frame	Steel tube		
Tires: Type Front Rear		Tubeless AT 26x9.0-14 or AT 26x9.0-12 or AT 25x8.0-12 AT 26x11.0-14 or AT 26x11.0-12 or AT 25x11.0-12	

SPECIFICATIONS

Item	ZFORCE 500 EX Specification
	CF500US-EX
Tire pressure: Front Rear	10.1 psi (70 kPa) 14.5 psi (100 kPa)
Brake system:	Front axles: Double-disc / Rear axles: Double-disc
Foot brake Type / Operation	Foot Operated
Parking brake Type / Operation	Four wheel disc Operated by hand Rear discs only
Brake Fluid Type	DOT 4
Suspension: Front suspension Rear suspension	Double A-arm independent Double A-arm independent

SPECIFICATIONS

Item	ZFORCE 500 EX Specification
	CF500US-EX
Shock absorber: Front shock absorber Rear shock absorber	Coil spring/Gas and Oil dampened Coil spring/Gas and Oil dampened
Wheel travel: Front wheel travel Rear wheel travel	6.3 in. (160 mm) 7.8 in. (200 mm)
Electrical system: Ignition Charging Battery	Electronic Rectified A/C 460 Watt @ 5000 rpm 12Vdc / 30 Amp Hr

SPECIFICATIONS

Item	ZFORCE 500 EX Specification
	CF500US-EX
Light system: Head lamp, low beam Head lamp, high beam Front position light Tail light/Brake light License plate light	H3 12V 55Wx2 H7 12V 55Wx2 LED LED Incandescent - 5Wx1
Dashboard	LED and LCD -- Non-serviceable
Fuses	Main – 40 Amp x 1 Auxiliary - 10 Amp x 2 Auxiliary – 15 Amp x 3 ECU – 5 Amp x 1 EPS – 30 Amp x 1 (if equipped)

SPECIFICATIONS

ZFORCE 500 Trail Specifications

Item	ZFORCE 500 Trail Specification
	CF500US
Overall Length	112.9 in. (2870 mm)
Overall Width	50.0 in (1270 mm)
Overall Height	70.5 in. (1790 mm)
Wheel Base	80.3 in. (2040 mm)
Minimum ground clearance	11.3 in. (287 mm)
Min. turning radius	374 in. (9500 mm)
Basic weight:	1272 lb. (577 kg)
Rear cargo box weight capacity	220.3 lb. (100 kg)
Maximum vehicle load allowed	573.2 lb.(260 kg)
Recommended towing capacities: Tongue weight Trailer and Cargo weight	110 lb. (50 kg) 334 lb. (125 kg)
Engine model and type	191R
Type	Liquid-cooled/4-stroke, 4 valves, SOHC

SPECIFICATIONS

Item	ZFORCE 500 Trail Specification
	CF500US
Bore x Stroke	3.5 x 3.0 in (91 x 76.2 mm)
Displacement	495 cc
Compression ratio	10.3:1
Starting type	Electric start
Lubrication type	Splash /pressure feed
Engine coolant: Type Capacity Mix Ratio	Commercially available – Safe for aluminum engines 3.1 qt. (3.0 L) 50% coolant / 50% distilled water
Engine oil: Type Engine oil volume: Capacity change / oil filter	SAE15W-40/SG (10W-40 acceptable alternative/cold weather) 2.95 qt. (2.8L)

SPECIFICATIONS

Item	ZFORCE 500 Trail Specification
	CF500US
Rear differential oil: Type Volume: Periodic oil change Capacity	SAE80W/90 GL-4 8.4 oz. (250ml) 10.1 oz. (300ml)
Front differential oil: Type Volume: Periodic oil change Capacity	SAE80W/90 GL-4 9.4 oz. (280ml) 11.1 oz. (330ml)
Air filter	Paper filter element with foam pre-filter
Fuel type Fuel tank capacity Fuel reserve amount at fuel gauge 'flash' (approximate)	89 Octane minimum unleaded gasoline 7.1 gallons (25 L) 0.9 gallons. (3.5 L)
Throttle Body type:	0GRB-173000-30000

SPECIFICATIONS

Item		ZFORCE 500 Trail Specification	
		CF500US	
Spark plug: type Spark plug gap		DCPR8E (NGK) .035~.045 in. (0.8~0.9 mm)	
Transmission	Transmission		CVT + Gear shift
	Gear shift/order		Manual / L – H – N – R – P
	CVT ratio		0.67~3.02
	Gear ratio	Low Gear	38/15=2.533
		High Gear	27/20=1.350
Reverse		29/14=2.071	
Chassis Frame	Steel tube		
Tires: Type Front Rear		Tubeless AT 26x9.0-14 AT 26x11.0-14	

SPECIFICATIONS

Item	ZFORCE 500 Trail Specification
	CF500US
Tire pressure: Front Rear	10.1 psi (70 kPa) 14.5 psi (100 kPa)
Brake system:	Front axles: Double-disc / Rear axles: Double-disc
Foot brake Type / Operation	Foot Operated
Parking brake Type / Operation	Four wheel disc Operated by hand Rear discs only
Brake Fluid Type	DOT 4
Suspension: Front suspension Rear suspension	Double A-arm independent Double A-arm independent

SPECIFICATIONS

Item	ZFORCE 500 Trail Specification
	CF500US
Shock absorber: Front shock absorber Rear shock absorber	Coil spring/Gas and Oil dampened Coil spring/Gas and Oil dampened
Wheel travel: Front wheel travel Rear wheel travel	6.3 in. (160 mm) 7.8 in. (200 mm)
Electrical system: Ignition Charging Battery	Electronic Rectified A/C 460 Watt @ 5000 rpm 12Vdc / 30 Amp Hr

SPECIFICATIONS

Item	ZFORCE 500 Trail Specification
	CF500US
Light system: Head lamp, low beam Head lamp, high beam Front position light Tail light/Brake light License plate light	H3 12V 55Wx2 H7 12V 55Wx2 LED LED Incandescent - 5Wx1
Dashboard	LED and LCD -- Non-serviceable
Fuses	Main – 40 Amp x 1 Auxiliary - 10 Amp x 2 Auxiliary – 15 Amp x 3 ECU – 5 Amp x 1 EPS – 30 Amp x 1 (if equipped)

SAFETY

Operator Safety

General Safety Precautions

⚠️WARNING

Failure to respect the warnings contained in this manual can result in serious injury or death. This vehicle is not a toy and can be hazardous to operate. This vehicle handles differently from other vehicles, such as cars. A collision or rollover can occur quickly, even during routine maneuvers like turning or driving over obstacles, if you fail to take proper precautions.

Read this owner's manual. Understand all safety warnings, precautions and operating procedures before operating this vehicle.

Age Restrictions

This vehicle is an ADULT VEHICLE ONLY. Operation is prohibited for anyone under the age of 16. No passengers under age 12 are allowed on CFMOTO vehicles designed to carry a passenger.

Know Your Vehicle

As the operator of the vehicle, you are responsible for your personal safety, the safety of others, and the protection of the environment. Read and understand your owner's manual, which includes valuable information about all aspects of your vehicle, including safe operating procedures.

SAFETY

Equipment Modifications

CFMOTO is concerned with the safety of our customers and for the general public. Therefore, we strongly recommend that consumers do not install on a vehicle, any equipment that may increase the speed or power of the vehicle, or make any other modifications to the vehicle for these purposes. Any modifications to the original equipment of the vehicle create a substantial safety hazard and increase the risk of body injury. The warranty on your vehicle is terminated if any unapproved accessory equipment has been added to the vehicle, or if any modifications have been made to the vehicle that increase its speed or power.

NOTE:

The addition of certain accessory equipment which may change the handling and performance characteristics of the vehicle include, but are not limited to; mowers, plow blades, oversize tires, sprayers, large racks, lift kits and trailers. Use only approved accessories, and familiarize yourself with their function and effect on the vehicle.

SAFETY

Avoid Carbon Monoxide Poisoning

All engine exhaust contains carbon monoxide, a deadly gas. Breathing carbon monoxide can cause headaches, dizziness, drowsiness, nausea, confusion and eventually death.

Carbon monoxide is a colorless, odorless, tasteless gas that may be present even if you do not see or smell any engine exhaust. Deadly levels of carbon monoxide can collect rapidly, and you can quickly be overcome and unable to save yourself. Also, deadly levels of carbon monoxide can linger for hours or days in enclosed or poorly ventilated areas.

To prevent serious injury or death from carbon monoxide:

- Never run the vehicle in poorly ventilated or partially enclosed areas.
- Never run the vehicle outdoor where engine exhaust can be drawn into a building through openings such as windows and doors.

Avoid Gasoline Fires and Other Hazards

Gasoline is extremely flammable and highly explosive. Fuel vapors can spread and be ignited by a spark or flame many feet away from the engine. To reduce the risk of fire or explosion, follow these instructions:

- Strictly adhere to proper fueling procedures
- Use only an approved gasoline container to store fuel.
- Never fill the gasoline container in the vehicle cargo box or on the vehicle. An electrical static discharge may ignite the fuel.
- Never start or operate the engine if the fuel cap is not properly installed. Gasoline is poisonous and can cause injury or death.
- Never siphon gasoline by mouth.

SAFETY

- If you swallow gasoline, get any in your eye(s), or inhale gasoline vapor, see a doctor immediately.
- If gasoline spills on you, wash with soap and water and change your clothes.

Avoid Burns from Hot Parts

The exhaust system and engine become hot during operation. Avoid contact during and shortly after operation to avoid burns.

Owner Responsibilities

Be Qualified and Responsible

Read this Owner's Manual and the warning decals on this vehicle carefully. Take a safety training course on open areas if available. Practice at low speeds. Higher speeds require greater experience, knowledge and suitable riding conditions. Become completely familiar with the operational controls and the general operation of the vehicle.

This vehicle is an ADULT VEHICLE ONLY. Operation is prohibited for anyone under 16 years of age. Operators must be tall enough to be properly seated back against the backrest with the seat belt fastened, to hold the steering wheel with both hands and still be able to reach the full stroke of brake and throttle pedals with the right foot, and able to firmly plant their left foot on the footrest.

Operators may be required to have a proper driver's license in accordance with local laws.

SAFETY

Carrying a Passenger

- Only carry one passenger. The passenger must be properly seated in the passenger seat.
- The passenger must be at least 12 years old and tall enough to always be properly seated against the backrest with the seat belt fastened, holding both handholds, and feet firmly planted; right foot on the footrest and the left foot on the vehicle floor.
- Never carry a passenger who has used drugs or alcohol, or is tired or ill. These slow reaction time and impair judgment.
- Instruct the passenger to read the vehicle's safety labels.
- Never carry a passenger if you judge their ability or judgement is insufficient to concentrate on the terrain conditions and adapt accordingly. More specifically for side-by-side vehicles, the passenger must also pay constant attention to the terrain ahead and be able to brace for bumps.

Riding Carefully

- This vehicle is not a toy and can be hazardous to operate. This vehicle handles differently from other vehicles such as motorcycles or cars. A collision or rollover can occur quickly, during abrupt maneuvers such as sharp turns, acceleration or deceleration, and driving on hills or over obstacles if you fail to take proper precautions.
- Never operate at excessive speeds. Always operate at a speed that is proper for the terrain, visibility, and operating conditions, and your experience.
- Never attempt jumps, side slides, donuts, or any other stunts.
- Never attempt rapid acceleration or deceleration when performing a sharp turn. This may result in a rollover.
- Never attempt skidding or sliding. If vehicle starts to skid or slide, counter steer in the direction of skidding or sliding. On extremely slippery surfaces, such as ice, go slowly and be very cautious in order to reduce the chance of skidding out of control.

SAFETY

- Always be sure there are no obstacles or people behind the vehicle when reversing. Pay attention to blind spots. When it is safe to proceed in reverse, go slowly.
- Never exceed the stated load limits for this vehicle. Cargo must be properly secured. Reduce speed, allow for greater braking distance and follow other instructions in this manual.
- Ensure that cargo is well distributed in the cargo box. Otherwise, it could change the center-of-gravity and may result in rollover.

Roll Over Protection System (ROPS)

- The ROPS on this vehicle meets the performance requirements of ISO 3471:2008. The ROPS can limit intrusions of outside objects and reduce your risk of injury in rollovers.
- Always follow all safe operating practices outlined in this manual to avoid vehicle rollover.
- Do not put your hands and/or feet outside of the vehicle when driving. The ROPS will not protect you from injury in all rollovers.
- Always have your authorized CFMOTO dealer thoroughly inspect the ROPS if it ever becomes damaged in any way. Occupant Restraint System
- This vehicle is designed to carry one driver and one passenger, both wearing proper protective gear.
- The driver and passenger must latch the side doors and wear the seat belts at all times when riding.

Terrain Conditions

- Avoid sharp turns, abrupt acceleration and sudden braking when passing public roads.
- Always go slowly and be extra careful when operating on unfamiliar terrain. Always be alert to changing terrain conditions when operating this vehicle. Take the time to learn how the vehicle performs in different environments.
- Never operate on excessively rough, slippery or loose terrain until you have learned and practiced the skills necessary to control this vehicle on such terrain. Always be especially cautious on these kinds of terrain.

SAFETY

- Never operate this vehicle on hills too steep for the vehicle or your abilities. Practice on small inclines.
- Always follow proper procedures for climbing or going down hills. Never go over the top of any hill at high speed.
- Never attempt steep hills or side hilling when pulling a trailer.
- Always check for obstacles before operating in a new area. Always follow proper procedures when operating over obstacles or fallen trees.
- Never operate this vehicle in deep water or fast flowing water. Remember that wet brakes may have reduced stopping ability. Test your brakes after leaving water. If necessary, apply them several times while driving slowly to let friction dry out the brakes.
- Always ensure to properly park the vehicle on the flattest terrain section available. Put the shift lever in PARK, stop the engine, and remove the key before leaving the vehicle.
- Never assume that the vehicle will go everywhere safely. Sudden changes in terrain caused by holes, depressions, banks, softer or harder ground, or other irregularities may cause the vehicle to topple or become unstable. To avoid this, slow down and always observe the terrain ahead. If the vehicle begins to topple or rollover, the best advice is to immediately steer in the direction of the rollover.
- Never attempt to prevent a rollover with your arms or legs. Always keep limbs inside the ROPS cage.

SAFETY

Safe Riding Gear

Always wear clothing suited to the type of riding. Operating this vehicle requires special protective clothing for comfort and to reduce the chance of injury:

1. A helmet is the most important piece of protective gear for safe riding. An approved helmet can prevent a severe head injury.
2. Eye protection. A pair of goggles or a helmet face shield offers the best protection for your eyes. They should be kept clean and be a shatterproof design. Do not depend on sunglasses for proper eye protection.
3. Off-road style gloves with knuckle pads are the best for comfort and protection.
4. The best footwear is a pair of strong over-the-calf boots with heels, like moto-cross boots.
5. Always wear long pants and long sleeve shirts to protect arms and legs. Riding pants and a jersey that have kneepads and shoulder pads provide the best protection.

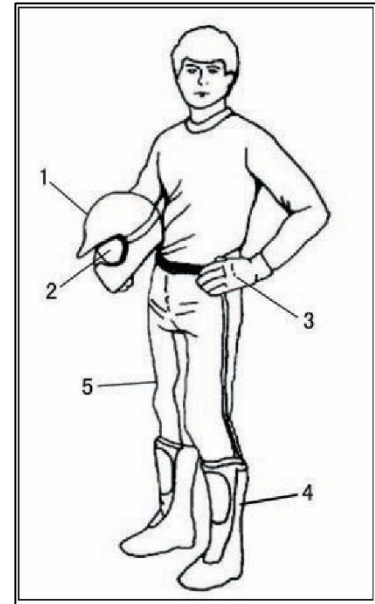

SAFETY

Safety Labels, Locations and Warnings

Warning labels have been placed on the vehicle for your protection. Read and follow the instructions on each decal carefully. If a decal becomes illegible or comes off, contact your dealer to purchase a replacement. Read and follow the safety warnings in this manual.

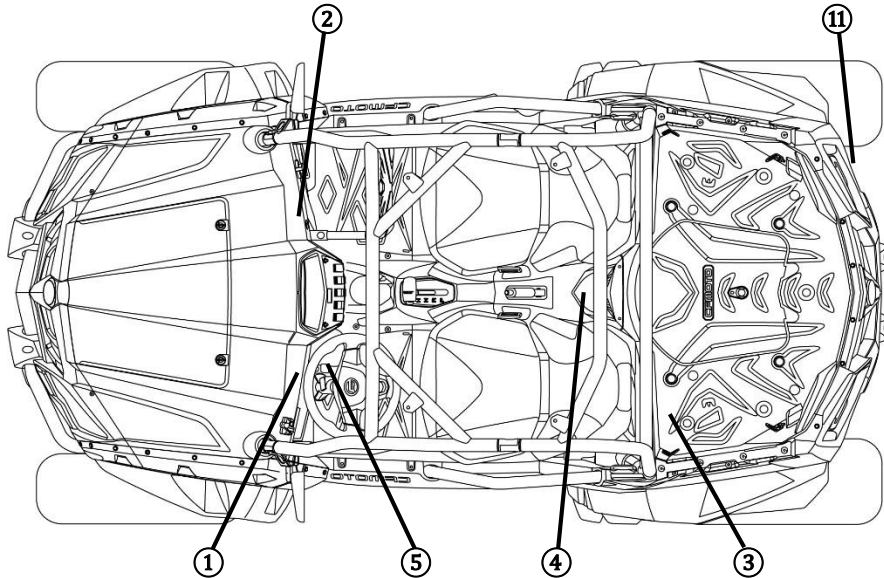

SAFETY

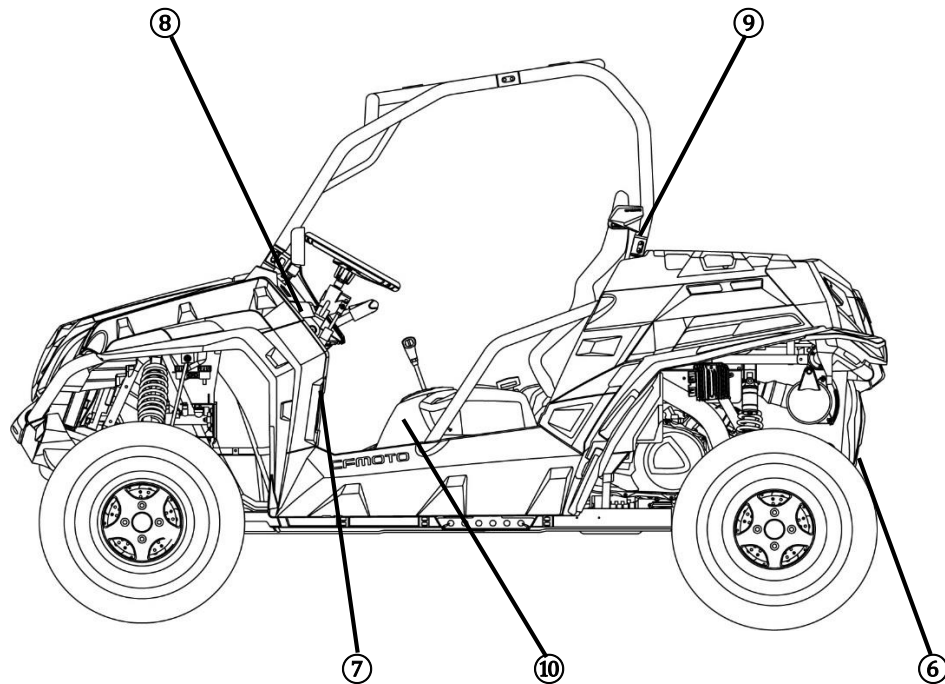

SAFETY

①

ZFORCE 1000

⚠ WARNING

Improper Use of Off-Highway Vehicles Can Cause Severe Injury or Death

This off-highway utility vehicle will handle and maneuver differently from an ordinary passenger car or other vehicle.

- Vehicle capacity: 1 operator and 1 passenger. Passenger must be able to reach and hold the handgrip inside enclosure.
- This vehicle is recommended only for operators 16 and older with a valid motor vehicle license. Adults must supervise use by minors. Check state laws for minimum age requirements.
- Gross Vehicle Weight Rating: 2039 lbs (925 kg) maximum including operator, passenger, accessories and cargo.
- Passenger and cargo can affect vehicle handling.

Be Sure Riders Pay Attention and Plan Ahead

If you think or feel the vehicle may tip or roll, reduce your risk to injury:

- Keep a firm grip on the steering wheel or handholds and brace yourself.
- Do not put any part of your body outside of the vehicle for any reason.

Be Prepared

- Fasten seat belts.
- Wear an approved helmet and protective gear.
- Always secure cab nets.
- Each rider must be able to sit with back against seat, feet flat on floor, and hands on steering wheel or handholds. Stay completely inside the vehicle.

Locate and Read Owner's Manual
Follow All Instruction and Warnings



8BY2-19003
US172

②

⚠ WARNING

Improper Use of Off-Highway Vehicles Can Cause Severe Injury or Death

Drive Responsibly

- Avoid loss of control and rollovers:
- Avoid abrupt maneuvers, sideways sliding, skidding or fishtailing, and never do donuts.
- Slow down before entering a turn.
- Avoid hard acceleration when turning, even from a stop.
- Plan for hills, rough terrain, ruts, and other changes in traction and terrain. Avoid paved surfaces.
- Avoid side hilling (riding across slopes).

Rollovers have caused severe injuries and death, even on flat, open areas.



Require Proper Use of Your Vehicle

Do your part to prevent injuries:

- Do not allow careless or reckless driving.
- Make sure operators are 16 or older with a valid driver's license.
- Do not let people drive or ride after using alcohol or drugs.
- Do not allow operation on public roads-collisions with cars and trucks can occur.
- Do not exceed seating capacity: 1 passenger.



Locate and Read Owner's Manual
Follow All Instruction and Warnings

ZFORCE 800

⚠ WARNING

Improper Use of Off-Highway Vehicles Can Cause Severe Injury or Death

This off-highway utility vehicle will handle and maneuver differently from an ordinary passenger car or other vehicle.

- Vehicle capacity: 1 operator and 1 passenger. Passenger must be able to reach and hold the handgrip inside enclosure.
- This vehicle is recommended only for operators 16 and older with a valid motor vehicle license. Adults must supervise use by minors. Check state laws for minimum age requirements.
- Gross Vehicle Weight Rating: 1940 lbs (880 kg) maximum including operator, passenger, accessories and cargo.
- Passenger and cargo can affect vehicle handling.

Be Sure Riders Pay Attention and Plan Ahead

If you think or feel the vehicle may tip or roll, reduce your risk to injury:

- Keep a firm grip on the steering wheel or handholds and brace yourself.
- Do not put any part of your body outside of the vehicle for any reason.

Be Prepared

- Fasten seat belts.
- Wear an approved helmet and protective gear.
- Always secure cab nets.
- Each rider must be able to sit with back against seat, feet flat on floor, and hands on steering wheel or handholds. Stay completely inside the vehicle.

Locate and Read Owner's Manual
Follow All Instruction and Warnings



7000-190201
US1363

③

⚠ WARNING

Severe INJURY or DEATH can result if you ignore the following:

- Maximum Load in Cargo Bed: 100kg (220lbs).
- Never carry passengers in cargo bed.
- Cargo can affect handling and stability. Read Owner's Manual before loading or towing.
- When loading with cargo or towing a trailer: Reduce speed and allow more room to stop. Avoid hills and rough terrain.
- Be sure cargo is secured - a loose load could change handling unexpectedly.
- Keep weight in the cargo bed centered, and as low and far forward as possible. Top-heavy loads increase the risk of overturn.



7000-190204 US1303

ZFORCE 500

⚠ WARNING

Improper Use of Off-Highway Vehicles Can Cause Severe Injury or Death

This off-highway utility vehicle will handle and maneuver differently from an ordinary passenger car or other vehicle.

- Vehicle capacity: 1 operator and 1 passenger. Passenger must be able to reach and hold the handgrip inside enclosure.
- This vehicle is recommended only for operators 16 and older with a valid motor vehicle license. Adults must supervise use by minors. Check state laws for minimum age requirements.
- Gross Vehicle Weight Rating: 1912 lbs (870 kg) maximum including operator, passenger, accessories and cargo.
- Passenger and cargo can affect vehicle handling.

Be Sure Riders Pay Attention and Plan Ahead

If you think or feel the vehicle may tip or roll, reduce your risk to injury:

- Keep a firm grip on the steering wheel or handholds and brace yourself.
- Do not put any part of your body outside of the vehicle for any reason.

Be Prepared

- Fasten seat belts.
- Wear an approved helmet and protective gear.
- Always secure cab nets.
- Each rider must be able to sit with back against seat, feet flat on floor, and hands on steering wheel or handholds. Stay completely inside the vehicle.

Locate and Read Owner's Manual
Follow All Instruction and Warnings



8BR0-190202
US1163

SAFETY

④



⑤



⑥



⑦



⑧

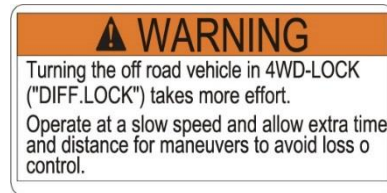

SAFETY

⑨ ZFORCE 1000



ZFORCE 800



ZFORCE 500



⑩ ZFORCE 1000/800

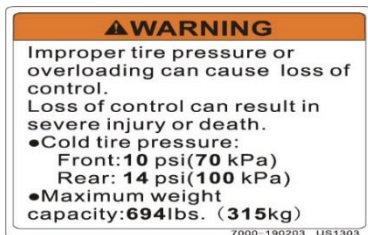

ZFORCE 500

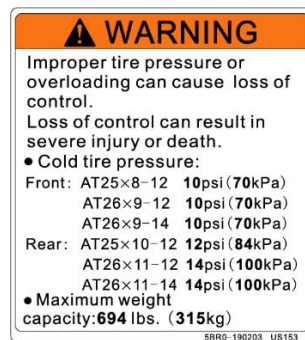

⑪



SAFETY

Potential Hazard Warnings

⚠️ WARNING

POTENTIAL HAZARD:

Operating this vehicle without proper instruction.

WHAT CAN HAPPEN:

The risk of an accident is greatly increased if the operator does not know how to operate the vehicle properly in different situations and on different types of terrain.

HOW TO AVOID THE HAZARD:

Beginning and inexperienced operators should complete a safety training course if offered by dealer. Operators should regularly practice the skills learned in the course and the operating techniques described in the owner's manual.

SAFETY

⚠️ WARNING

POTENTIAL HAZARD:

Failure to follow the age recommendations for this vehicle.

WHAT CAN HAPPEN:

Severe injury and/or death could occur if a child under the minimum age recommendation operates this vehicle.

Even though a child may be within the recommended age group for operating, he/she may not have the skills, abilities, or judgment needed to operate safely and could be susceptible to accident or injury.

HOW TO AVOID THE HAZARD:

Operation is prohibited for anyone under 16 years of age.

SAFETY

⚠️WARNING

POTENTIAL HAZARD:

Carrying more passengers than the rated capacity.

WHAT CAN HAPPEN:

A passenger not seated in the vehicle could be ejected from the vehicle unexpectedly or make contact with moving components, both of which can result in severe injury or death. Carrying 2 or more passengers is prohibited.

HOW TO AVOID THE HAZARD:

Never allow multiple passengers.

⚠️WARNING

POTENTIAL HAZARD:

Operation on paved surfaces such as sidewalks, trails, parking lots, or public highways and streets.

WHAT CAN HAPPEN:

All-terrain tires are designed for off-road use. Driving on paved surfaces greatly affects how a vehicle handles, which can result in loss of control and/or an accident.

HOW TO AVOID THE HAZARD:

Never drive on paved surfaces. If it is unavoidable, slow down and do not make sudden turning or braking maneuvers.

Never operate on public highways or streets if it is not allowed by law. Check local laws to determine if it is legal to do so.

SAFETY

⚠️WARNING

POTENTIAL HAZARD:

Operating this vehicle without wearing approved helmet, eye protection, and protective clothing.

WHAT CAN HAPPEN:

Operating without an approved helmet increases the risk of a severe head injury or death in the event of an accident. Operating without eye protection could result in an accident and could increase the chance of a severe eye injury in the event of an accident. Operating without protective clothing could increase the chance of a severe injury.

HOW TO AVOID THE HAZARD:

Always wear an approved helmet that fits properly. Always wear eye protection (goggles or face shield), gloves, long-sleeved shirt or jacket, long pants, and over-the-calf boots.

SAFETY

⚠️WARNING

POTENTIAL HAZARD:

Operating the vehicle after consuming alcohol or drugs.

WHAT CAN HAPPEN:

Consumption of alcohol and/or drugs could seriously affect operator judgment. Reaction time may be slower and operator balance and perception could be affected. Consumption of alcohol and/or drugs before or while operating a vehicle could result in an accident causing severe injury or death.

HOW TO AVOID THE HAZARD:

Never consume alcohol or drugs before or while operating the vehicle.



SAFETY

⚠️WARNING

POTENTIAL HAZARD:

Operating at excessive speeds.

WHAT CAN HAPPEN:

Excessive speed increases the operator's chance of losing control, which can result in an accident.

HOW TO AVOID THE HAZARD:

Always operate at a speed that's proper for the terrain, visibility and operating conditions, and your experience.

⚠️WARNING

POTENTIAL HAZARD:

Attempting wheelies, jumps and other stunts.

WHAT CAN HAPPEN:

Attempting stunts increases the chance of an accident, including an overturn.

HOW TO AVOID THE HAZARD:

Never attempt wheelies, jumps, or other stunts. Avoid exhibition driving.

SAFETY

⚠️WARNING

POTENTIAL HAZARD:

Failure to inspect the vehicle before operating. Failure to properly maintain the vehicle.

WHAT CAN HAPPEN:

Poor maintenance increases the possibility of an accident or equipment damage.

HOW TO AVOID THE HAZARD:

Always inspect your vehicle before each use to make sure it's in safe operating condition.

Always follow the inspection and maintenance procedures and schedules described in the owner's manual.

⚠️WARNING

POTENTIAL HAZARD:

Extending arms, hands, or legs outside the ROPS bars of the vehicle during operation.

WHAT CAN HAPPEN:

Severe injury can occur to arms, hands, or legs if the vehicle overturns or rolls over in an accident.

HOW TO AVOID THE HAZARD:

Always keep arms, hands, or legs inside the vehicle, hands on the steering wheel or hand grip, and keep both feet on the footrests of the vehicle during operation.

SAFETY

⚠️WARNING

POTENTIAL HAZARD:

Failure to use extra caution when operating on unfamiliar terrain.

WHAT CAN HAPPEN:

Unfamiliar terrain may contain hidden rocks, bumps, or holes that could cause loss of control or overturn.

HOW TO AVOID THE HAZARD:

Travel slowly and use extra caution when operating on unfamiliar terrain. Always be alert to changing terrain conditions.

⚠️WARNING

POTENTIAL HAZARD:

Turning improperly.

WHAT CAN HAPPEN:

Improper turns could cause loss of control and lead to a collision or overturn.

HOW TO AVOID THE HAZARD:

Always follow proper procedures for turning as described in the owner's manual. Practice turning at slow speeds before attempting to turn at faster speeds. Never turn at excessive speed.

SAFETY

⚠️WARNING

POTENTIAL HAZARD:

Failure to use extra caution when operating on excessively rough, slippery or loose terrain.

WHAT CAN HAPPEN:

Operating on excessively rough, slippery or loose terrain could cause loss of traction or loss of control, which could result in an accident or overturn.

HOW TO AVOID THE HAZARD:

Do not operate on excessively rough, slippery or loose terrain until you've practiced and learned the skills necessary to control the vehicle on such terrain. Always use extra caution on rough, slippery or loose terrain.

SAFETY

⚠️ WARNING

POTENTIAL HAZARD:

Climbing excessively steep hills or climbing hills improperly.

WHAT CAN HAPPEN:

Improper hill climbing could cause loss of control or overturn.

HOW TO AVOID THE HAZARD:

Never operate on hills too steep for the vehicle or for your abilities. Practice on smaller hills before attempting large hills. Always check the terrain carefully before ascending any hill. Never climb hills with excessively slippery or loose surfaces. Never open the throttle suddenly while traveling uphill. The vehicle could flip over backwards. Never go over the top of any hill at high speed. An obstacle, a sharp drop, another vehicle, or person could be on the other side of the hill.

SAFETY

⚠️ WARNING

POTENTIAL HAZARD:

Traveling down excessively steep hills.

WHAT CAN HAPPEN:

Improper downhill travel could cause loss of control or overturn.

HOW TO AVOID THE HAZARD:

Never operate on hills too steep for the vehicle or for your abilities. Practice on smaller hills before attempting large hills. Always check the terrain carefully before attempting any hill. Never descend hills with excessively slippery or loose surfaces.

NOTE:

Always check the terrain carefully before descending a hill. Never travel down a hill at high speed. Avoid traveling down a hill at an angle. Travel straight down the hill when possible.

SAFETY

⚠️ WARNING

POTENTIAL HAZARD:

Improperly crossing hills and turning on hills.

WHAT CAN HAPPEN:

Improperly crossing or turning on hills could cause loss of control or overturn.

HOW TO AVOID THE HAZARD:

Use extra caution when turning on any hill. Avoid crossing the side of a steep hill.

WHEN CROSSING THE SIDE OF A HILL:

Always follow proper procedures as described in the owner's manual. Avoid hills with excessively slippery or loose surfaces.

SAFETY

⚠️ WARNING

POTENTIAL HAZARD:

Stalling, rolling backwards while climbing a hill.

WHAT CAN HAPPEN:

The vehicle could overturn.

HOW TO AVOID THE HAZARD:

Maintain a steady speed when climbing a hill.

IF ALL FORWARD SPEED IS LOST:

Close the throttle. Apply the brake. When fully stopped, shift the gear selector to the park position.

IF THE VEHICLE BEGINS ROLLING:

Never apply engine power. Carefully apply the foot brake while rolling backwards. When fully stopped, keep the brake applied, shift the gear selector to the parking position, and determine the best way to safely change direction.

SAFETY

⚠️WARNING

POTENTIAL HAZARD:

Improperly operating over obstacles.

WHAT CAN HAPPEN:

Operating over obstacles could cause loss of control or overturn.

HOW TO AVOID THE HAZARD:

Before operating in a new area, check for obstacles. Avoid operating over large obstacles such as rocks and fallen trees when possible. If unavoidable, use extreme caution and always follow proper procedures as outlined in the owner's manual.

⚠️WARNING

POTENTIAL HAZARD:

Skidding or sliding.

WHAT CAN HAPPEN:

Skidding or sliding can cause loss of control. If the tires regain traction unexpectedly, the vehicle could overturn.

HOW TO AVOID THE HAZARD:

On slippery surfaces such as ice, travel slowly and use extra caution to reduce the chance of skidding or sliding out of control.

SAFETY

⚠️WARNING

POTENTIAL HAZARD:

Overloading the vehicle or carrying/towing cargo improperly.

WHAT CAN HAPPEN:

Overloading and towing can cause changes in vehicle handling, which could lead to loss of control or an accident.

HOW TO AVOID THE HAZARD:

Never exceed the stated load capacity for this vehicle.

Cargo should be properly distributed and securely attached. Reduce speed and always use low gear when carrying cargo or pulling a trailer. Allow a greater distance for braking. Always follow the instructions in the owner's manual for carrying cargo or pulling a trailer.

SAFETY

⚠️ WARNING

POTENTIAL HAZARD:

Operation the vehicle through deep or fast-flowing water.

WHAT CAN HAPPEN:

The tires may float, causing loss of traction and loss of control, which can lead to an accident or overturn.

HOW TO AVOID THE HAZARD:

Avoid operating through deep or fast-flowing water. If it is unavoidable to enter water that exceeds the recommended maximum depth, travel slowly, balance your weight carefully, avoid sudden movements, and maintain a slow and steady forward motion. Do not make sudden turns or stops, and do not make sudden throttle changes. Wet brakes may have reduced stopping ability. Always test the brakes after leaving the water. If necessary, apply the brakes several times while driving slowly to dry out the pads.

SAFETY

⚠️WARNING

POTENTIAL HAZARD:

Improperly operating in reverse.

WHAT CAN HAPPEN:

The vehicle could collide with an obstacle or person, resulting in severe injury.

HOW TO AVOID THE HAZARD:

Before shifting into reverse gear, always check for obstacles or people behind the vehicle. When it's safe to proceed, back slowly.

⚠️WARNING

POTENTIAL HAZARD:

Operating this vehicle with improper tires, or with improper or uneven tire pressure.

WHAT CAN HAPPEN:

Use of improper tires, or operation of the vehicle with improper or uneven tire pressure, could cause loss of control or an accident.

HOW TO AVOID THE HAZARD:

Always use the size and type of tires specified in the owner' s manual. Always maintain proper tire pressure.

SAFETY

⚠️WARNING

POTENTIAL HAZARD:

Operating the vehicle with improper modifications.

WHAT CAN HAPPEN:

Improper installation of accessories or modification of the vehicle may cause changes in handling which could lead to an accident.

HOW TO AVOID THE HAZARD:

Never modify the vehicle through improper installation or use of accessories. All parts and accessories added to the vehicle must be genuine parts or equivalent components designed for use on this vehicle, and they should be installed and used according to approved instructions. Consult your dealer for more information.

SAFETY

⚠️WARNING

POTENTIAL HAZARD:

Operating on frozen bodies of water.

WHAT CAN HAPPEN:

Severe injury or death can result if the vehicle falls through the ice.

HOW TO AVOID THE HAZARD:

Never operate the vehicle on a frozen body of water.

⚠️WARNING

Leaving the keys in the ignition can lead to unauthorized use of the vehicle, resulting in serious injury or death. Always remove the ignition key when the vehicle is not in use.

⚠️WARNING

After any overturn or accident, have a qualified service dealer inspect the entire vehicle for possible damage, including (but not limited to) brakes, throttle and steering systems.

SAFETY

WARNING

Safe operation of this vehicle requires good judgement and physical skills. Persons with cognitive or physical disabilities who operate this vehicle have an increased risk of overturn and loss of control, which could result in severe injury or death

WARNING

Exhaust system components are very hot during and after use of the vehicle. Hot components can cause serious burns and fire. Do not touch hot exhaust system components. Always keep combustible materials away from the exhaust system. Use caution when traveling through tall grass, especially dry grass.

CONTROLS AND FEATURES

Controls and Features

Primary Controls

Steering Wheel - ①

The steering wheel is located in front of the driver's seat.

Tilt Lever - ②

The tilt feature allows the steering wheel to be adjusted to fit the operator.

Throttle Pedal - ③

The throttle pedal is located to the right of the brake pedal. The throttle pedal controls engine rpm and vehicle speed. To control vehicle speed, press on the throttle pedal with your right foot. Always check the pedal function before driving.

NOTE: The throttle pedal has adjustment bolts (A) to compensate for throttle cable freeplay and wear. Contact your dealer for adjustments to the throttle pedal.

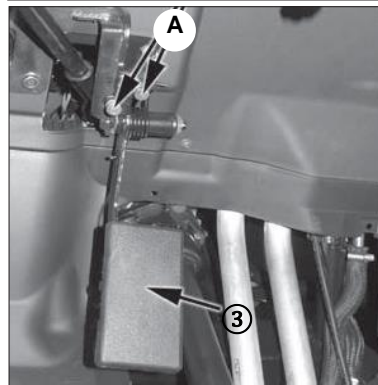
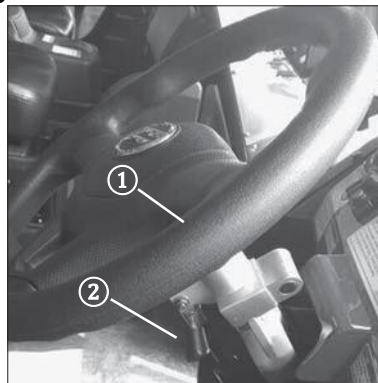

CONTROLS AND FEATURES

Brake Pedal - ④

The brake pedal is located to the left of the throttle pedal. Release the throttle pedal and press the brake pedal with your foot to slow or stop the vehicle.

Shift Lever - ⑤

The shift lever is located to the right of the driver's seat. The shift lever is used to change the transmission gear selection:

Shift Button - Press the shift button (A) before shifting the gear.

L – Low Gear. (B) The low speed range of the gearbox. It allows the vehicle to move slowly with maximum torque at the wheels.

CAUTION: To avoid damage to the CVT system, always use low gear for constant slow travel, to pull a trailer, carry heavy cargo, go over obstacles, or drive up and down hills.

H – High Gear. (C) The high speed range of the gearbox. It is the normal driving speed range. It allows the vehicle to reach its maximum speed.

N – Neutral. (D) In neutral position the engine power take-off is disengaged.

R – Reverse. (E) The reverse gear position allows the vehicle to go backwards.

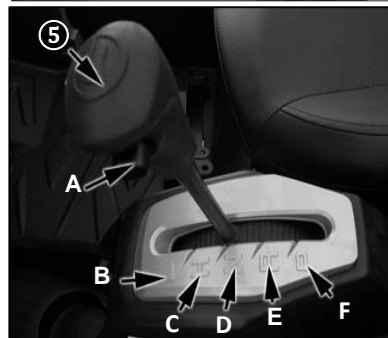
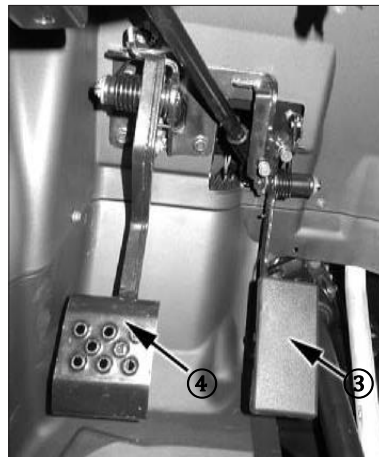

CONTROLS AND FEATURES

NOTE:

In reverse operation, the engine's RPM is limited, thus limiting the vehicle reverse speed under 25 km/h (15.5 mile/h).

WARNING

Use extreme caution driving downhill in reverse. Gravity can increase the vehicle speed above the set limited reverse speed.

P – *Park*. The park position (F) locks the gearbox to help prevent vehicle movement.

WARNING



Always shift to PARK (P) position when the vehicle is not in operation. The vehicle can roll if the shift lever is not set to 'P'. Always use the auxiliary parking brake as an additional precaution to prevent vehicle movement.

Secondary Controls

Ignition Key Switch and Engine Stop Switch - ⑥

The ignition key switch and engine stop switch are located on the bottom left of the dashboard.

The ignition switch has 3 positions. Use the key to control the ignition switch and start the engine. When the key is in the position of “OFF”, it can be removed from the ignition switch.

Ignition Key Switch	OFF Position (1)	Engine is shut down. All electrical except the winch motor and DC outlets are disabled.
	ON Position (2)	The electrical system of the vehicle is activated.
	START Position (3)	Turn ignition key to “  ” to start the engine. Ignition key returns to “On ” when released.
Engine Stop Switch		Engine is stopped.
		Engine is ready for work.

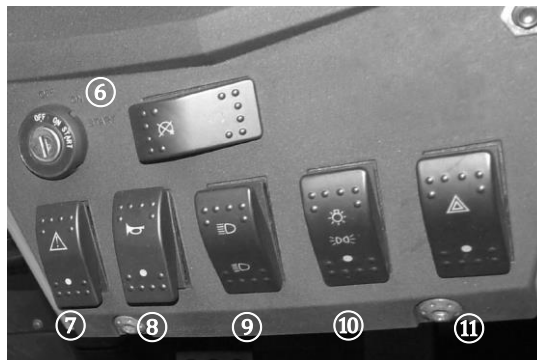

CONTROLS AND FEATURES

WARNING

Do not leave the ignition key inserted when the operator is away. An unauthorized use of the vehicle by others may result in serious injury or death. Always remember to remove the ignition key when the vehicle is not in use.

NOTE: Do not keep the ignition key switch in 'START' for more than 10 seconds.

Speed Limit Override Switch - ⑦

The engine is normally speed limited when operating in 4WD-LOCK. If conditions require more engine power:

- Release the throttle and press the button to override the speed limiting function. The override indicator light will come on.
- Reapply the throttle while this button is pressed.
- Releasing the button restores the speed limiting function.

NOTE: Speed limit override is not available in 2WD.

WARNING



Pressing the override button while the throttle is open in speed limiting mode may cause sudden acceleration, resulting in a loss of control, severe injury, or death. Always release the throttle before pressing the override button.

CONTROLS AND FEATURES

Horn Button - ⑧



Press the button ''. The horn will sound.

Low Beam / High Beam Switch - ⑨

	High Beam is selected when the switch is in this position.
	Low Beam is selected when the switch is in this position.

Main Light Switch - ⑩

The main light switch consists of 3 positions:

	Head lights and tail lights 'ON' when the switch is in this position.
	Head lights 'OFF' and tail lights 'ON' when the switch is in this position.
	Head lights and tail lights are 'OFF' when the switch is in this position.

NOTE:

Ignition key must be turned to 'ON' before operating head lights.

CAUTION

Do not use the headlights with the engine turned off for more than 15 minutes. The battery may discharge to a point that the starter motor will not operate properly. If this should happen, remove the battery and recharge it.

CONTROLS AND FEATURES

Hazard Switch - ⑪

(available only in select countries)

When using the hazard switch function, the front and rear turn signal lights will flash. Also, the hazard switch indicator light in the dashboard will light up.

2WD / 4WD Switch - ⑫

This vehicle is equipped with an on-command “2WD”/“4WD” and front diff-lock “LOCK”/“4WD” switch on the left side of the dashboard. Select the appropriate drive mode according to terrain and conditions:

- **Two-wheel drive (2WD):** Power is supplied to the rear wheels only.
- **Four-wheel drive (4WD):** Power is supplied to the rear wheels, and to the front wheels.
- **Four-wheel drive with diff-lock (4WD-LOCK):** Power is supplied to the rear and front wheels and the front differential is locked. Unlike 4WD mode, all the wheels turn at the same speed. Speed is limited to 22 mph (35 km/h).





CAUTION

The vehicle must be stopped to engage or disengage 2WD / 4WD and 4WD-LOCK. Mechanical damage may occur if the switch is engaged or disengaged while driving.

CONTROLS AND FEATURES

On-Command 2WD / 4WD / 4WD-LOCK Switch Operation

To change from 2WD to 4WD: Stop the vehicle. Verify the mode lever is moved to the left, and then press the switch to “4WD”. The 4WD indicator “” will display in the dashboard.

To change from 4WD to 2WD: Stop the vehicle. Verify the mode lever is moved to the left, and then depress the switch to “2WD”. The 2WD indicator “” will display in the dashboard.

To change to 4WD-LOCK: Stop the vehicle. To lock the front differential while in 4WD mode, verify the mode lever is moved to the right, and then depress the switch to “LOCK”. The 4WD-LOCK indicator “” will display in the dashboard.

NOTE: 4WD-LOCK OPERATION:

- Steering will require greater effort in 4WD-LOCK mode. This is normal.
- When the switch is set to “LOCK”, the front diff-lock indicator light will flash until the front diff is locked.
- If the indicator light is flashing, turning the steering left and right will help the front gear locking mechanism to engage.
- Riding before the front differential lock is properly engaged (e.g., the indicator light is flashing) will cause the engine speed to be limited until engagement is complete.
- When the vehicle is in 4WD-LOCK, the maximum traveling speed is limited to 22 mph (35 km/h).
- If conditions require full engine power to be available, press the override switch on the dashboard to disable the 4WD-LOCK speed limiter.

CONTROLS AND FEATURES

Hand Brake - 13

This vehicle is equipped with an auxiliary hand brake, which is located to the right of the driver's seat. Pull back on the lever to apply the rear brakes and prevent the vehicle from rolling when parked on an incline.

To release the hand brake, pull up slightly and press the release button at the end of the lever, then push the lever down to its original position.

CAUTION

Never depend on the transmission parking feature alone if the vehicle is parked on a hill. Always apply the hand brake and block the wheels on the downhill side of the vehicle to prevent movement. It is recommended to park the vehicle on level ground.

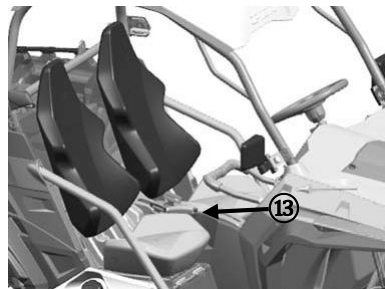

Vehicle Features

Feature Locations - 1

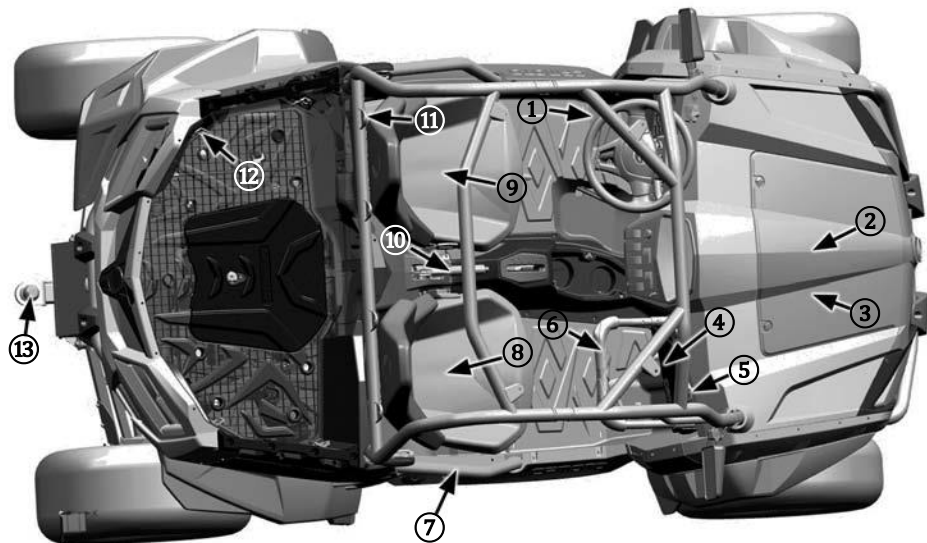

CONTROLS AND FEATURES

Feature Locations – 2



CONTROLS AND FEATURES

Feature Descriptions

Footrests - ①

This vehicle is equipped with driver and passenger footrests to allow firmly planting of feet on the vehicle floor, which helps minimize the risk of leg or foot injury and maintain proper body position while riding. Always wear appropriate footwear.

Front Storage Compartment - ②

The front of the vehicle is equipped with a front storage compartment under the hood to carry the tool kit and light objects. The capacity is 5.56 lb (2.5 kg).

Tool Kit- ③

A tool kit with basic tools is provided. It is typically stored in the front storage compartment.

Glove Box - ④

The vehicle is equipped with a closed glove box made to carry the winch controller and light objects. The capacity is 5.56 lb. (2.5 kg).

Winch Cable Controller and Power Port - ⑤

This vehicle comes with a winch cable controller, which plugs into the power port on the dashboard.

Passenger Handholds - ⑥

The passenger must hold both handholds securely during riding. No part of the body should be outside of the cab to prevent possible injury.

WARNING

Never use any part of vehicle cage as handholds. Hands can be struck by objects outside the cockpit or crushed in a rollover.

CONTROLS AND FEATURES

Shoulder Guards - ⑦

The vehicle is equipped with shoulder guards to help restrain the entire body of driver and passenger inside vehicle.

Driver Seat - ⑧

The driver's seat offers fore and aft adjustments. To adjust the seat, move the seat lever to unlock the seat. Release the lever to lock the seat into desired position.

Passenger Seat - ⑨

The passenger seat is not adjustable.

Hand Brake - ⑩

Press the release button and pull up lever to engage the hand brake. Press the release button and push down to disengage the hand brake before driving.

Seat Belts - ⑪

This vehicle is equipped with 3-point seat belts to help protect the driver and passenger in the event of collisions, rollovers or tip-overs and to help keep occupants in the cab. The seat belt indicator light will flash if the seat belt is not fastened during driving.

Anchoring Hooks - ⑫

4 anchoring hook points are located inside the cargo area to secure cargo inside the cargo box.

CONTROLS AND FEATURES

Towing - ⑬

This vehicle is equipped with a 2x2 in. (51x51mm) box size standard hitch support, a trailer light receptacle at the inner right rear fender of the vehicle, and a trailer wiring adapter. Please consult with your dealer on towing and the use of trailers before using your vehicle.

Winch - ⑭

This vehicle is equipped with a 3000-lb winch. The winch controller is located in the glove compartment. A winch controller power port is located on the right side dashboard. To preserve battery power, only operate the winch while the engine is running. Please refer to your winch manual for further information or consult with your dealer on the use of the winch before using your vehicle.

Fuel Tank Fill Cap - ⑮

The fuel tank fill cap is located on the passenger side of the vehicle near the passenger seat. To fill the tank, grasp the fuel cap firmly, then turn counter-clockwise and remove it. Reinstall the fuel cap securely after fuel tank fill is completed. The fuel tank capacity is 6.9 gal. (26L).

Cargo Box and Engine Access Panel - ⑯

Refer to the safety decals on the cargo box for load information. The cargo box floor contains an access panel which can be removed for maintenance.

CONTROLS AND FEATURES

Fuel Minimum Octane Rating and Safety Warnings

The recommended fuel for your vehicle is 89 Octane minimum, premium or mid-grade fuel (a maximum blend of 10% ethanol is allowed). Non-oxygenated (ethanol-free) fuel is recommended for best performance in all conditions.

WARNING

- Gasoline is highly flammable and explosive under certain conditions.
- Allow the engine and exhaust system to cool before filling the tank.
- Always exercise extreme caution whenever handling gasoline.
- Always refuel with the engine stopped, and outdoors or in a well ventilated area.
- Never carry a plastic container with gasoline in the cargo area while riding. Static electricity between the cargo area and container could cause a spark.
- Do not smoke or allow open flames or sparks in or near the area where refueling is performed, or where gasoline is stored.
- Do not overfill the tank. Do not fill to the tank neck.
- If gasoline spills on your skin or clothing, immediately wash it off with soap and water and change clothing.
- Never start the engine or let it run in an enclosed area. Engine exhaust fumes are poisonous and can cause loss of consciousness or death in a short time.
- The engine exhaust from this product contains chemicals known to cause cancer, birth defects or other reproductive harm. Operate this vehicle only outdoors or in well-ventilated areas.

CONTROLS AND FEATURES

12 Volt Accessory Power

An auxiliary 12Vdc power outlet is provided on the right side dashboard for operating accessories such as hand held spot lights and charging electronic devices. Please consult with your dealer on the use of powered accessories with your vehicle.

Brake Fluid Reservoir and Level Indicator

The brake master cylinder reservoir level can be viewed under the left side wheel well. Check the brake master cylinder fluid level before each use of the vehicle. If the fluid level is lower than the “low” mark, determine the cause or refill with brake fluid as necessary.

NOTE:

When checking the fluid levels, the vehicle must be on level ground. If the fluid level is lower than the “lower” mark, add DOT4 brake fluid. Do not overfill.

WARNING

An over-full master cylinder may cause brake drag or brake lockup, which could result in an accident causing serious injury or death. Maintain brake fluid at the recommended level. Do not overfill.

WARNING

Never store or use a partial bottle of brake fluid. Brake fluid is hygroscopic, meaning it rapidly absorbs moisture from the air. The moisture causes the drop of boiling temperature of the brake fluid, which can lead to early brake fade and the possibility of accident or severe injury. After opening a bottle of brake fluid, always discard any unused portion.

CONTROLS AND FEATURES

Dashboard Gauge Indicators and Warnings

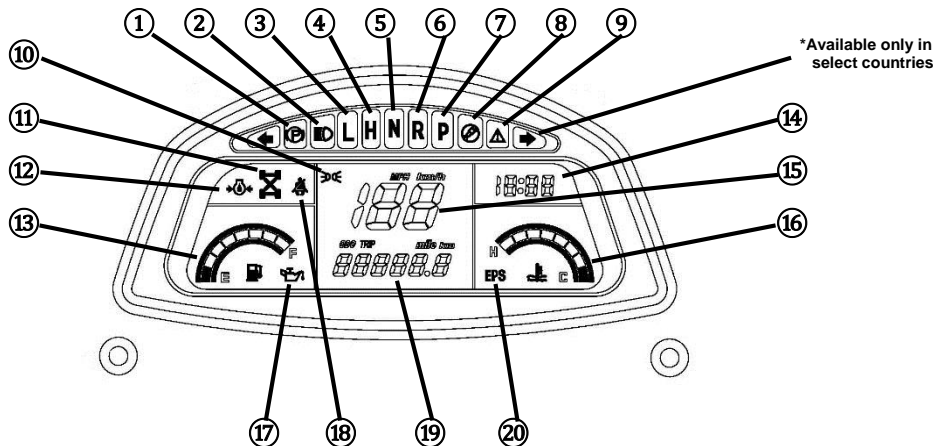

- | | | | |
|-------------------------------|---------------------|--------------------|------------------|
| ① - Parking Brake 'ON' | ② - High Beam 'ON' | ③ - Low Gear | ④ - High Gear |
| ⑤ - Neutral | ⑥ - Reverse | ⑦ - Parking | ⑧ - EFI Fault |
| ⑨ - Speed Limit Override 'ON' | ⑩ - Tail Light 'ON' | ⑪ - 4WD Mode | ⑫ - Oil Pressure |
| ⑬ - Fuel Gauge | ⑭ - Clock | ⑮ - Speedometer | ⑯ - Engine Temp |
| ⑰ - Oil Change | ⑱ - Seatbelt | ⑲ - Odo/Trip/Rpm/V | ⑳ - EPS Fault |

CONTROLS AND FEATURES

Indicators and Warnings

- ① - Hand brake 'ON'. Illuminates when the hand brake lever is pulled.
- ② - High Beam 'ON'. Illuminates when the headlight switch is in this position.
- ③ - 'L'= Low Gear Position. This indicator displays when the transmission is in Low.
- ④ - 'H'= High Gear Position; This indicator displays when the transmission is in High.
- ⑤ - 'N'= Neutral Position; This indicator displays when the transmission is in Neutral.
- ⑥ - 'R'= Reverse Position; This indicator displays when the transmission is in Reverse.
- ⑦ - 'P'= Parking Position; This indicator displays when the transmission is in Park.
- ⑧ - EFI Fault. This indicator light flashes when a fault occurs in the Electronic Fuel Injection system.
- ⑨ - Speed Limit Override 'ON'. This indicator light comes on when pressing the override switch. Always exercise caution when using the override button.
- ⑩ - Tail Light 'ON'. This indicator displays when the main headlight switch is set to this position.
- ⑪ - 4WD Indicator. This dashboard section corresponds to the drive method chosen. The front differential gear case contains the synchronizing component that signals the display.
- ⑫ - Fuel Gauge. This dashboard section displays the current gas remaining in the tank. 'F' indicates full. 'E' indicates stand-by fuel. When the indicator enters the red area, the fuel remaining is approximately 3.5L (.92 gal). Fuel must be added as soon as possible.

CONTROLS AND FEATURES

- ⑬ - EFI Fault. This indicator light displays when a fault occurs in the Electronic Fuel Injection system.
- ⑭ - Clock. This dashboard section can be adjusted to the correct time using the right 'ADJ' button below the dashboard.
- ⑮ - Speedometer. This dashboard section can be toggled to display the vehicle speed in Kilometers per hour (Km/h) or Miles Per Hour (MPH).
- ⑯ - Engine Temperature. This dashboard section displays the current coolant temperature, 'C' is low temperature, 'H' is high temperature. Both over-low and over-high are abnormal. Idle the vehicle to warm the engine when it's too cold, and park the vehicle when it's too hot to prevent the coolant from boiling. Keep the coolant temperature in a normal range.
- ⑰ - Oil Change Reminder. This indicator displays when the pre-programmed time limit has been reached for oil change service.
- ⑱ - Seatbelt Reminder. This indicator displays when the seat belt is not fastened.
- ⑲ - Odometer / Trip/ Rpm / Volt. This dashboard section can be toggled using the left 'SEL' button to display the accumulated distance traveled in miles/kilometers; '**ODO**' -The accumulated vehicle distance traveled, '**TRIP**' - The trip distance traveled, '**RPM**' - The engine speed in Revolutions Per Minute (RPM), '**V**' - Battery voltage.
- ⑳ - EPS Fault. This indicator light flashes when a fault occurs in the Electronic Power Steering system.

*Select countries (markets) are equipped with turn signals and indicators as standard equipment.

CONTROLS AND FEATURES

Nagivation / Settings / Adjustments

Item	Displays	SEL / ADJ Button	Result
Metric / Standard Toggle	Speed/Distance	Long Press SEL Button	Metric ↔ Standard Values
Distance/RPM/Item Toggle	Odometer Trip Distance Engine RPM Battery Voltage	Short Press SEL Button	ODO→TRIP→RPM→V→ODO
Trip Distance Reset	Trip Distance	Long Press SEL Button in Odometer mode	Distance reset to zero
Clock - Hours Adjustment	Time	Short Press ADJ Button	Incremental 1-12
Clock - Minutes Adjustment	Time	Long Press ADJ Button	Incremental 00-59

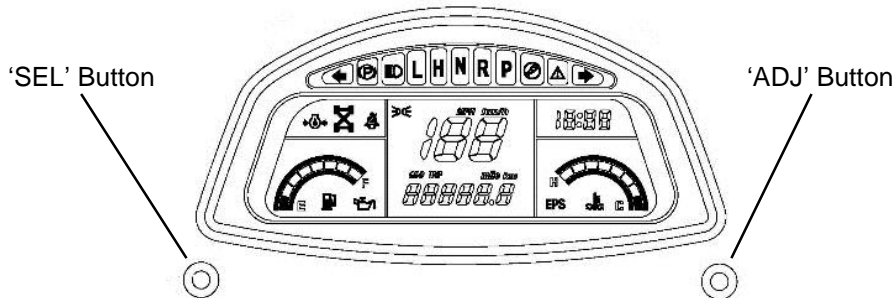

Operating Your Vehicle

Break-In Period

The break-in period for a new engine is very important. Careful treatment of a new engine at the beginning of ownership will result in more efficient performance and longer life. Perform the following procedures carefully:

1. Select an open area that allows room to familiarize yourself with vehicle operation and handling.
2. Place the vehicle on a level surface.
3. Fill the fuel tank with gasoline.
4. Check the engine oil level. Add the recommended oil if necessary to maintain the oil level between the minimum and maximum indicators on the dipstick.
5. Position yourself in the operating position on the vehicle, fasten the seatbelt and safety nets, and start the engine. Allow the engine to idle for a short period before operating.
6. Press the foot brake, select the desired gear, and then release the foot brake.
7. Apply throttle. Drive slowly at first, varying throttle positions to $\frac{1}{2}$ open for 10 hours, then vary to $\frac{3}{4}$ open for another 10 hours. Do not operate at sustained idle or sustained wide open throttle.
8. Do not pull or carry any heavy loads during the break-in period.
9. Periodically check coolant level, controls, etc. along with the items outlined in the periodic maintenance chart.
10. At the end of the break-in period, change the oil and filter (20hrs or 466 miles / 750km).

OPERATING YOUR VEHICLE

CAUTION

During the 20-hour break-in period:

- Do not operate at sustained full throttle. Damage to engine parts or decrease engine life may result if excessive wide open throttle is used during the first 20 hours of use.
- Do not run engine with throttle over 1/2 open during the first 10 hours of use.
- Do not run engine with throttle over 3/4 open during the first 10 to 20 hours of use.
- Do not haul or tow heavy cargo.
- Use of any oil other than those recommended may cause serious engine damage. CFMOTO recommends the use of SAE 15W-40/SG JASO-certified oil for 4-stroke engines. If 15W-40 oil is not available in your area, 10W-40 is an acceptable alternative, as long as it carries an API rating of 'SG' or better and is JASO-certified.

NOTE:

800 engines contain a wet clutch that requires JASO-certified engine oil, commonly sold as motorcycle engine oil.

OPERATING YOUR VEHICLE

Pre-Ride Inspection

Before each use of the vehicle, a best practice is to complete the pre-ride inspection checklist.

WARNING

If a proper inspection is not done before each use, severe damage to the vehicle, severe injury, or death could result. Always inspect the vehicle before each use to ensure it is in proper operating condition.

Pre-Ride Checklist		
Item	Remarks	Page Reference
Air Filter	Inspect. Clean or replace as necessary	134
Air Box Sediment Tube	Drain deposits whenever visible	134
Brake System / Lever Travel	Ensure proper operation	100
Brake Fluid Reservoirs	Ensure proper level	83,92
Front Suspension	Inspect. Lubricate if necessary	164
Rear Suspension	Inspect. Lubricate if necessary	164
Steering	Ensure free operation	-
Tires	Inspect condition and pressure	165
Wheels / Fasteners	Inspect. Ensure fastener tightness	165
Frame Fasteners	Inspect. Ensure fastener tightness	-
Engine Fuel and Oil	Inspect for leaks. Ensure proper levels	134
Coolant Level	Ensure proper level	152
Coolant Hoses	Inspect for leaks	-
Gear case Oil	Ensure proper level. Front and Rear	144
Gear Shifting	Ensure proper operation	-

OPERATING YOUR VEHICLE

Pre-Ride Checklist		
Item	Remarks	Page Reference
Throttle Pedal	Ensure proper operation	-
Headlights	Ensure proper operation	-
Brake Light / Tail Light	Ensure proper operation	-
Riding Gear	Wear helmet, gloves, protective clothing	51

Throttle

Before starting the engine, check the throttle pedal to be sure it is operating smoothly. Make sure it returns to the idle position as soon as the pedal is released. Regulate the speed of the vehicle by varying the throttle position. Because the throttle is spring-loaded, the vehicle will decelerate and the engine should return to idle speed any time your foot is removed from the throttle pedal.

Foot Brake

Before operating the vehicle, push down on the pedal to apply the front and rear brakes. When squeezed, the lever or pedal should feel firm. A soft brake pedal would indicate a possible fluid leak or low master cylinder fluid level, which must be corrected before riding. Contact your dealer for proper diagnosis and repairs.

Starting the Engine

WARNING

Never run an engine in an enclosed area. Engine exhaust contains poisonous carbon monoxide and can cause loss of consciousness, resulting in severe injury or death.

Starting a cold engine

1. Verify the gear selector is shifted to the Parking or Neutral position.
2. Apply the foot brake.
3. Turn the engine stop switch and main key switch to “” (ON)
4. Verify the throttle is completely closed, then turn the key start switch.
5. Once the engine starts, continue to warm the engine for a short period before operating the vehicle.

NOTE:

Do not activate the starting system more than 10 seconds on each attempt. If the engine fails to start, release the start switch, pause a few seconds before the next attempt, then try the start switch again. Each attempt should be as short as possible to preserve battery energy.

The engine can be started in any gear if the brake is applied. However, a best practice is to shift into Neutral or Park before starting the engine. If the neutral indicator light on the dashboard does not come on when the gear selector is in the neutral position, contact your dealer to inspect the indicator electrical circuit or adjust the gear shifting system.

OPERATING YOUR VEHICLE

CAUTION

Allow the engine to warm up for a short period before operating the vehicle. Operating the vehicle immediately after starting could cause engine damage.

Shifting the Transmission

CAUTION

To avoid transmission damage, return the throttle to the closed position, stop the vehicle, and apply the foot brake before shifting.

NOTE:

Low gear is the preferred transmission gear selection for all forward motion other than prolonged high speed travel.

Shifting out of Park

1. Verify the throttle is closed.
2. Apply the foot brake and press the gear selector button.
3. Shift to the desired gear by moving the gear selector along the shift guide.

Shifting: Neutral to High Gear

1. Verify the throttle is closed and the vehicle is stopped completely.
2. Apply the foot brake.
3. Shift to 'H' by moving the gear selector along the shift guide.

OPERATING YOUR VEHICLE

Shifting: High Gear to Low Gear

1. Verify the throttle is closed and the vehicle is stopped completely.
2. Apply the foot brake.
3. Shift to 'L' by moving the gear selector along the shift guide.

Shifting: Low Gear to High Gear

1. Verify the throttle is closed and the vehicle is stopped completely.
2. Apply the foot brake.
3. Shift to 'H' by moving the gear selector along the shift guide.

Shifting: to Reverse Gear

1. Verify the throttle is closed and the vehicle is stopped completely.
2. Apply the foot brake and press the gear selector button.
3. Shift to 'R' by moving the gear selector along the shift guide.
4. Check behind you for people or obstacles, then release the rear brake pedal.
5. Apply the throttle lever gradually and continue to watch behind you while moving backward.

WARNING

Before shifting into reverse, make sure there are no obstacles or people, and the area is safe behind you. When it is safe to proceed, go slowly.

Avoid excessive throttle operation while in speed limit mode, as it may cause fuel to build in the exhaust, resulting in engine popping and/or engine damage.

OPERATING YOUR VEHICLE

Shifting: to Park

1. Verify the throttle is closed and the vehicle is stopped completely.
2. Apply the foot brake and press the gear selector button.
3. Shift to 'P' by moving the gear selector along the shift guide. Shake the vehicle forward and backward to verify that parking is engaged.

NOTE:

- The gear selector cannot be shifted into reverse gear without pressing the shift button.
- The gear shift indicators should display corresponding to the actual gear position, if the indicator does not display, ask your dealer to inspect the vehicle electrical circuit or adjust the gear shifting system.
- Due to the synchronizing mechanism in the engine, an indicator may not display until the vehicle starts moving.
- Do not use high gear for continuous slow speed travel or towing, as this can lead to excessive heating of the clutch system, which may damage components.

OPERATING YOUR VEHICLE

Safe Operation - Driving Safely

Responsibilities of the operator

As the operator of this vehicle, your common sense, judgement, and abilities are the only factors that will prevent injury to yourself, to others around you, and/or damage to the vehicle or environment.

Recreational, group, and distance riding

One of the benefits of this vehicle is that it can take you off-road away from most communities. Stay away from areas designated for other types of off-road use unless it is specifically allowed. This includes snowmobile trails, equestrian trails, cross country ski trails, mountain bike trails, etc. Join a local ATV club. A club can provide you with a map and advice, or inform you about areas where you can ride.

Always keep a safe distance from other riders ahead of you and behind you when riding in a group. Never operate carelessly or make unexpected maneuvers with other vehicles close by. Stay on designated trails and riding areas, and discourage others from operating in unauthorized locations.

Avoiding Accidents, Rollovers and Tip-overs

Side-by-side vehicles handle differently from other vehicles. Side-by-side vehicles are designed to handle off-road terrain (for example, the wheel base and track width, ground clearance, suspension, drivetrain, tires, etc.), and as a result, can overturn in situations where vehicles designed for use primarily on paved or smooth terrain may not.

OPERATING YOUR VEHICLE

A rollover or other accident can occur quickly during abrupt maneuvers such as:

- Sharp turns or hard acceleration.
- Deceleration when turning.
- When driving on hills or over obstacles.

Abrupt maneuvers or aggressive driving can cause rollovers or loss of control even in flat open areas. If the vehicle rolls over, any part of your body (such as arms, legs, or head) outside of the cockpit can be crushed and trapped by the cage or other parts of the vehicle. You can also be injured by impact with the ground, cab, or other objects.

To reduce the risk of rollovers:

- Use care when turning.
- Adjust steering inputs accordingly to your speed and environment.
- Slow down before entering a turn.
- Avoid hard braking during a turn.
- Avoid sudden or hard acceleration when turning, even from a stop or low speed.
- Never attempt donuts, skids, slides, fishtails, jumps, or other stunts.
- If vehicle starts to skid or slide, steer in the direction of the skid or slide.
- Never slam the brakes and lock the wheels.
- This vehicle is built primarily for OFF-ROAD purposes. Riding on paved surfaces may seriously affect vehicle handling and control. If you must drive on paved surfaces for a short distance, reduce speed and avoid abrupt inputs to steering wheel, accelerator and brake pedals.

OPERATING YOUR VEHICLE

This vehicle can roll over sideways, or tip over forward or backwards on slopes or uneven terrain:

- Avoid side hilling (driving along the slope rather than up or down a hill). When possible, drive straight up and down inclines rather than across them. If you must side hill, use extreme caution and avoid slippery surfaces, objects, or depressions. If you feel the vehicle start to rollover or slide sideways, steer downhill if possible.
- Avoid steep hills and follow procedures in this manual for climbing and descending hills.
- Sudden changes in terrain such as holes, depressions, banks, softer or harder ground or other irregularities may cause the vehicle to tip or become unstable. Observe the terrain ahead and slow down in areas of uneven terrain.

This vehicle will handle differently when carrying or pulling a load:

- Reduce speed and follow instructions in this manual for carrying cargo or pulling a trailer.
- Avoid hills and rough terrain.
- Allow more distance to stop.

Be prepared in case of rollover:

- Latch side doors and fasten seat belts to help you avoid sticking out arms or legs.
- Never grab the cage while riding. Hands can be crushed between the cage and the ground in a rollover. Keep hands on the steering wheel or handholds.
- Never try to stop a rollover using your arms or legs. If you think that the vehicle may tip or roll, the driver should keep both hands on the steering wheel and both feet firmly planted on the floor. The passenger should keep both hands on the handholds and both feet firmly planted on the floor.

OPERATING YOUR VEHICLE

Avoiding Collisions

At higher speeds, there is an increased risk of losing control, particularly in challenging off-road conditions, and the risk of injury in a collision is greater. Never operate at excessive speeds. Always go at a speed that is proper for the terrain, visibility, and operating conditions, and your experience. This vehicle does not have the same kind of protection for collisions as a car; for example, there are no air bags, the cab is not fully enclosed, and it is not designed for collisions with other vehicles. Therefore, it is particularly important to fasten seat belts, latch side doors, and wear proper riding gear.

Environment

Off-road recreation is a privilege. Maintain your privilege by respecting the environment and the rights of others to enjoy it.

Chasing wildlife is illegal. Wildlife can die of exhaustion if chased by a motorized vehicle.

Never purposely damage the terrain unless the operating area is designated for that type of activity.

Observe the rule...“what you take in, carry out”. Do not litter.

OPERATING YOUR VEHICLE

Practice Exercises

Before you go out for a ride, it is very important to familiarize yourself with the handling of your vehicle by practicing in a controlled environment. Find a suitable area to practice and perform the following exercises. It should be at least 147x147 ft. (45x45 m), and free of obstacles like trees and large rocks.

Remember: Avoid higher speeds until you are thoroughly familiar with the operation of your vehicle.

NOTE:

Low gear is the preferred transmission gear selection for all forward motion other than prolonged high speed travel. Do not use high gear for continuous slow speed travel or towing, as this can lead to excessive heating of the clutch system, which may damage components.

Turning Exercise

Turning is one of the most frequent causes of accidents. It is easier for the vehicle to lose traction or rollover if you turn too sharply, or go too fast. Slow down when you approach a turn.

Practice turning:

- First, learn how to perform slight right turns at very low speeds. Release the throttle before turning and slowly reapply the throttle.
- Repeat the turning exercise, but this time maintain the throttle at the same level while turning.
- Finally, repeat the turning exercise while accelerating slowly.
- Practice exercises turning to the left.

OPERATING YOUR VEHICLE

Note how your vehicle reacts in these different exercises. CFMOTO recommends releasing the throttle before entering a turn to help initiate directional change. You will feel the lateral force increasing with the speed and with your steering input. The lateral force should be maintained as low as possible to make sure it does not cause the vehicle to roll over.

U-turn Exercise

Practice doing U turns:

- Accelerate slowly and while remaining at low speed, gradually turn the steering wheel to the right until you have completed the U-turn.
- Repeat U-turn exercise with different steering inputs and always at a very low speed.
- Repeat U turn exercise to the left.

As mentioned before in this manual, do not ride on paved surfaces. The vehicle behavior will not be the same, increasing the risk of rollover.

Braking Exercise

Practice braking to get familiar with the brake response:

- Practice braking at low speed first, then increase the speed.
- Practice braking in straight line at different speeds and different braking forces.
- Practice emergency braking. Optimal braking is obtained in straight line, with high force applied, without locking the wheels.

Remember, braking distance depends on vehicle speed, load and the type of surface. Also, the tires and brakes conditions play a major role.

OPERATING YOUR VEHICLE

Reverse Exercise

Practice using the reverse:

- Place 1 cone marker on both sides of the vehicle beside each rear wheel.
- Move the vehicle forward until you can see the cone markers behind you, then stop the vehicle. Acknowledge the distance required to see obstacles behind you.
- Learn how the vehicle handles in reverse and reacts with steering inputs.
- Always perform this reverse exercise at slow speeds.
- Become familiar with the use of the speed limit override function (4WD-LOCK only). Do not make abrupt steering inputs while using the override, as it increases the risks of rollover.

Emergency Engine Stopping Exercise

Learn how to stop your engine quickly in an emergency situation:

- While running at low speed, simply turn the ignition key to the off position. This is to familiarize you with the vehicle's reaction when the engine is turned off while driving and to develop this reflex.

Operating Your Vehicle

Off-Road Operation

The very nature of off-road operation is dangerous. Any terrain which has not been specially prepared to carry vehicles presents an inherent danger where terrain substance, shape, and steepness are unpredictable. The terrain itself presents a continual element of danger, which must be knowingly accepted by anyone venturing over it.

An operator who takes a vehicle off-road should always exercise the utmost care in selecting the safest path and keeping close watch on the terrain ahead. This vehicle should never be operated by anyone who is not completely familiar with the driving instructions applicable to the vehicle, nor should it be operated on steep or treacherous terrain.

General Driving Tips

Care, caution, experience and driving skill are the best precautions against the hazards of vehicle operation. Whenever there is the slightest doubt that the vehicle can safely negotiate an obstacle or a particular piece of terrain, always choose an alternate route. In off-road operation, power and traction, not speed, are important. Never drive faster than visibility and your ability to select a safe route permit. Never operate the vehicle if the controls do not function normally. See your dealer.

Operating in Reverse

When operating in reverse, check that the path behind the vehicle is free of people or obstacles. Pay attention to blind spots. When it is safe to proceed in reverse, go slowly and avoid sharp turns.

 WARNING
--

Steering inputs in reverse operation increase the risk of rollover.

OPERATING YOUR VEHICLE

WARNING

When driving downhill in reverse, gravity can increase the vehicle speed above the set limited reverse speed. Failure to use caution when operating in reverse can result in serious injury or death.

NOTE:

This vehicle is equipped with a reverse speed limiter function. In reverse operation, the engine RPM is limited, thus limiting the vehicle reverse speed. Do not operate at wide open throttle. Open the throttle just enough to maintain a desired speed.

Crossing Paved Roads

If you have to cross a paved road, ensure to have complete visibility on both sides for incoming traffic and decide on exit point on other side of road. Drive in a straight line toward that point. Do not make sharp direction changes or abrupt accelerations as it may result in a rollover situation. Do not travel on sidewalks or bicycle trails, as they are designated specifically for those uses.

Riding on Paved Surfaces

Avoid paved surfaces. This vehicle is not designed to operate on paved surfaces and is more likely to roll over. If you must drive on pavement, turn gradually, go slowly, and avoid abrupt acceleration and braking.

OPERATING YOUR VEHICLE

Shallow Water Crossing

Water can be a unique hazard. If it is too deep the vehicle may “float” and topple. Check the water depth and current before you attempt to cross any water. Water depth should not exceed 23.6 in. (60 cm) to safely cross the obstacle.

Beware of slippery surfaces such as rocks, grass, logs, etc., both in the water and on its banks. A loss of traction may occur. Do not attempt to enter the water at high speed. Water will affect the braking ability of your vehicle. Make sure you dry the brakes by applying them several times while driving slowly after the vehicle leaves the water.

What to do if vehicle is submerged

If the vehicle becomes immersed, it will be necessary to have it transported to your dealer as soon as possible. Do not attempt to re-start the engine, as water may have been ingested into the cylinders, which can cause internal damage.

Riding in Mud, Ice or Snow

When performing a pre-ride inspection, pay special attention to locations on the vehicle where mud, ice and/or snow accumulations may obstruct visibility of the tail lamps, clog ventilation openings, block the radiator and fan, and interfere with the movement of controls. Before starting with your vehicle, check the steering, throttle and brake pedals for interference-free operation.

Whenever this vehicle is driven on a snow or ice covered path, the tire grip is generally reduced, causing the vehicle to react differently to control inputs from the operator.

OPERATING YOUR VEHICLE

Riding on Sand

Sand and riding on sand dunes is a unique experience, but there are some basic precautions that should be observed. Wet, deep, or fine sand may create a loss of traction and cause the vehicle to slide, drop off or become “bogged” down. If this occurs, look for a firmer base. Again, the best advice is to slow down and be watchful of the conditions.

When riding on sand dunes, it is advisable to equip the vehicle with an antenna-type safety flag. This will help make your location more visible to others over the next sand dune. Proceed carefully should you see another safety flag ahead.

Riding on Gravel, Loose Stones, or Other Slippery Surfaces

Riding on gravel or loose stones is very similar to riding on ice. They affect the steering of vehicle, possibly causing it to slide and tip over especially at high speeds. In addition, braking distance may be affected. Remember that “gunning” the throttle or sliding may cause loose stones to be ejected rearwards which could hit other people.

Crossing Obstacles

Obstacles on the trail should be traversed with caution. This includes rocks, fallen trees, and depressions. You should avoid them whenever possible. Remember that some obstacles are too large or dangerous to cross and should be avoided. As a guideline, never attempt to cross an obstacle higher than the ground clearance of the vehicle. Small rocks or small fallen trees may be safely crossed. Approach obstacles at low speed and to as much a right angle as possible. Adjust speed without losing momentum and do not accelerate abruptly. The passenger must grasp handholds firmly and brace feet on the floor.

OPERATING YOUR VEHICLE

Hill Driving Conditions

When driving on hills or slopes, two things are highly important: be prepared for slippery surfaces or terrain variations, obstacles, and brace yourself properly inside vehicle. If you climb or descend a hill that is too slippery or has too loose a surface, you can lose control. If you go over the top of a hill at high speed, you may not have time to prepare for the terrain on the other side. Avoid parking on a slope. Always put the shift lever in PARK and activate the hand brake when stopped or parked, especially on an incline, to avoid rolling. If you must park on a steep incline, block the wheels on the downhill side using rocks or other suitable material.

Uphill Driving

Use the low gear (L) for uphill driving. Due to its configuration, this vehicle has very good traction even while climbing, so much so that tip-over is possible before traction is lost. For example, it is common to encounter terrain situations where the top of the hill has eroded to a point that the hill peak rises very sharply. This vehicle is not designed to negotiate such a condition. Take an alternate route.

If you feel that the slope is getting too steep to climb, apply the brakes to immobilize the vehicle. Put the shift lever in reverse (R), and back straight down the hill, barely releasing brakes to remain at low speed. Do not attempt to turn around. Never coast downhill while the vehicle is in neutral. Do not perform hard braking, as it increases the risk of tip-over.

Downhill Driving

This vehicle can climb steeper slopes than it can descend safely. Therefore, it is essential to assure that a safe route exists to descend a slope before you climb it. Decelerating while negotiating a slippery downhill slope could “toboggan” the vehicle, causing it to slide. Maintain steady speed and/or accelerate slightly to regain control. Never slam the brakes and lock the wheels.

OPERATING YOUR VEHICLE

Hauling and Towing Loads

Your vehicle can help you perform a number of different light tasks ranging from snow removal, to pulling wood, or carrying cargo. This can change the vehicle handling. To prevent possible injury, follow the instructions and warnings in this manual and on the vehicle.

Always respect the load limits of the vehicle. Overloading the vehicle can overstress the components and cause failure.

Carrying Loads

The load limit of the vehicle including the weight of operator, passenger, cargo, accessories and trailer tongue weight is: **694 lb. (315 kg)**

Following is an example of suitable total vehicle load distribution:

EXAMPLE OF SUITABLE VEHICLE TOTAL LOADS				
Operator and Passenger	Cargo Box Load	Accessories	Tongue Weight	Total Vehicle Load
550 lb. (250 kg)	220.31 lb. (100 kg)	10.6 lb. (4.8 kg)	110 lb. (50 kg)	694 lb. (315 kg)

OPERATING YOUR VEHICLE

Vehicle Settings When Carrying Loads

If the total load approaches 694 lb. (315 kg), including weight of operator, passenger, cargo, accessories and trailer tongue weight:

- Inflate the tires to maximum pressure 10 PSI (70 kPa) Front, 14 PSI (100 kPa) Rear.
- Readjust the suspension coil spring preload accordingly.
- Operate with the shift lever in L (low gear) when carrying heavy loads in the cargo box and/or pulling a trailer.

Load Distribution

Your vehicle has been designed to carry or tow a certain amount of load. Always:

- Read and understand the load distribution warnings listed on the warning labels.
- Never exceed the specified weights.
- Cargo weight should be mounted as low as possible.
- When operating over rough or hilly terrain with loads or towing, reduce speed and cargo to maintain stable driving conditions.

OPERATING YOUR VEHICLE

Pulling or Towing

Your vehicle is equipped with a hitch receptacle and winch for towing or pulling.

Pulling a Load

- Never pull a load by attaching it to the cage. This can cause the vehicle to tip over. Use only the trailer hitch or winch (if installed) to pull a load.
- When pulling loads with a chain or cable, ensure that there is no slack before starting and maintain tension while pulling.

 WARNING
--

Slack can cause a chain or cable to break and snap back, possibly causing injury.

- When pulling a load, respect the maximum hauling capacity.
- If pulling another vehicle, be sure that someone is controlling the pulled vehicle. They must brake and steer to prevent the vehicle from going out of control.
- Reduce your speed when pulling a load and turn gradually to avoid chains, straps, ropes or cables from catching on the rear wheels. Avoid hills and rough terrain. Never attempt steep hills. Allow more distance for braking, especially on inclined surfaces. Be careful not to skid or slide.
- Before pulling loads with a winch, refer to the winch Owner's Manual.

OPERATING YOUR VEHICLE

Towing a Load

If a trailer is used behind the vehicle, make sure that its hitch is compatible with the one on the vehicle. Make sure the trailer is horizontal with the vehicle. Use safety chains or cables that keep the trailer secured to the vehicle in the event of a hitch failure.

Improperly loading a trailer may cause loss of control. Respect the recommended maximum hauling capacity and maximum tongue load. Make sure there is at least some weight on the tongue. Follow these guidelines for hauling and towing of cargo:

WARNING

Overloading the vehicle, carrying or towing cargo improperly, can alter the vehicle handling and may cause loss of control or braking instability.

- Always use low gear while towing to avoid clutch wear and belt issues.
- Reduce speed when hauling or towing loads.
- Never exceed the stated load capacity for this vehicle.
- All loads must be secured before operation. Unsecured loads may shift and create unstable operating conditions, which could result in loss of control of the vehicle.
- When operating over rough or hilly terrain, reduce speed and cargo to maintain stable driving conditions.
- Use extreme caution when applying brakes with a loaded vehicle. Avoid terrain or situations that may require backing downhill.
- Load weight distribution should be as low as possible. Carrying a high load raises the center of gravity and creates an unstable operating condition. Reduce load weight when the cargo center of gravity is high.
- When handling off-centered loads that cannot be centered, secure the load and operate with extra caution.

OPERATING YOUR VEHICLE

- When operating with loads extending beyond the cargo area, stability and maneuverability may be adversely affected, causing the machine to overturn.
- Towing a load while carrying cargo may cause an imbalanced condition that increases the possibility of vehicle overturn. Balance loads proportionally, but do not exceed the stated load capacity.
- Always attach to the towable using the hitch point and hardware specifically made for towing. Never exceed the recommended tongue weight.
- Using chains, straps, rope or other materials to tow objects is not recommended, as these items could get caught in the rear wheels, resulting in vehicle damage or personal injury.
- While towing, the vehicle should never exceed 10 mph (16 km/h) towing a load on a level surface. Vehicle speed should never exceed 5mph (8 km/h) when towing loads in rough terrain, while cornering, or while ascending or descending a hill.
- When stopped or parked, block the vehicle and trailer wheels from possible movement.
- Use caution when disconnecting a loaded trailer; it or its load may topple on you or others.

MAXIMUM HAULING CAPACITY			
Type of Attachment	Trailer Load Allowed	Tongue Weight Allowed	Note
2 in. (51 mm X 51 mm) hitch ball support	550 lb. (250 kg)	110 lb. (50 kg)	Includes trailer and trailer load.

MAINTENANCE

Maintenance

Careful periodic maintenance will help keep your vehicle in the safest, most reliable condition. Inspection, adjustment, and lubrication of important components are explained in the maintenance schedule.

Inspect, clean, lubricate, adjust, and replace parts as necessary. When inspection reveals the need for replacement parts, always use genuine parts available from your dealer.

NOTE:

Periodic service and adjustments are critical. If you are not familiar with performing safe service and adjustment procedures, have a qualified dealer perform the required maintenance for you.

NOTE:

Pay special attention to the engine oil level during cold weather operation. A rise in engine oil level can indicate contaminants collecting in the oil sump or crankcase. Change oil immediately if the oil level begins to rise. Monitor the oil level, and if it continues to rise, discontinue use and determine the cause, or see your dealer.

NOTE:

The 800 engine contains a wet clutch assembly which requires the use of JASO-certified engine oil. To avoid damage to the wet clutch, always use engine oil that is JASO-certified for wet clutches, commonly sold as motorcycle oil.

Severe Use Definition

CFMOTO defines severe vehicle use as:

- Frequent immersion in mud, water or sand
- Racing or race-style high RPM use
- Prolonged low speed, heavy load operation
- Extended engine idle
- Short trip cold weather operation
- Vehicles used in commercial operations

If your vehicle use matches any of these definitions, decrease the service intervals by 50%.

General Recommended Lubrication

Check all components at the intervals outlined in the Periodic Maintenance Schedule. Items not listed in the schedule should be lubricated at the general lubrication interval.

Key Points of Lubrication

- Change lubricants more often under severe use, such as wet or dusty conditions.
- Use All Season Grease on pivot points.
- Lubricate every 310.6 miles (500km), before long periods of storage, after pressure washing, or after submerging drivetrain.

MAINTENANCE

General Fluid/Lubricant Maintenance Items

Item	Type	Method
Engine oil	SAE15W-40/SG JASO rated	Unscrew, clean, insert and remove dipstick to check oil level
Brake fluid	DOT4	Keep level between upper and lower lines
Coolant	50/50 Mix	Keep level between upper and lower lines
Front gear case oil	SAE75W/90GL-5	Keep level at the filler rim
Rear gear case oil	SAE75W/90GL-5	Keep level at the filler rim
Suspension Pivots	All Season Grease	Grease gun - Pump grease until it flows lightly from the pivot point

MAINTENANCE

Periodic Maintenance Schedule and Icon Key

Maintenance intervals in the following schedule are based upon average riding conditions and an average vehicle speed of approximately 12.4 mph (20 km/h). Vehicles subjected to severe or commercial use must be inspected and serviced more frequently. The following icon keys are used to note special circumstances:

- ▶ = Perform the procedure more often on vehicles subjected to severe use.
- = Have an authorized dealer perform repairs that involve this component or system.
- ◆ = Emissions related components. Have an authorized dealer perform repairs that involve this component or system.

 WARNING
--

Improperly performing the procedures marked as '■' could result in component failure and lead to serious injury or death. Have an authorized dealer perform these services.

MAINTENANCE

Maintenance Schedule

Item		Maintenance Schedule Key ▶ ■ ◆ - See page 125		
		Calendar-based Maintenance Interval (service whichever interval comes first)		
		CALENDAR	Miles (Km)	Remarks
■	Steering	Pre-Ride		Make adjustments as required
▶	Front suspension / CV axles	Pre-Ride		
▶	Rear suspension / CV axles	Pre-Ride		
▶	Tires	Pre-Ride		
▶	Brake fluid level	Pre-Ride		
▶	Brake lever/Pedal travel	Pre-Ride		
▶	Brake system function	Pre-Ride		
▶	Wheels / Fasteners	Pre-Ride		
▶	Frame fasteners	Pre-Ride		
▶	Engine oil level	Pre-Ride		

MAINTENANCE

Item		Maintenance Schedule Key ► ■ ◆ - See page 125		
		Calendar-based Maintenance Interval (service whichever interval comes first)		
		CALENDAR	Miles (Km)	Remarks
►	Air box sediment tube	Pre-Ride		Drain and clean housing if deposits are visible
	CVT inlet / outlet pipe and sediment tube	Pre-Ride		Drain and clean housing if deposits are visible. Check often if operating in wet conditions.
►	Air inlet / Air filter			Inspect and replace more often under severe use conditions.
►	Coolant	Pre-Ride	932 (1500)	Inspect reservoir level daily; Initial check at 250km; Change coolant every 2 years/6000km
	Head light / Tail light	Pre-Ride		Check operation
	Engine oil and filter change (Break-in)		155 (250)	Break-in oil change: 750km
■ ◆	Engine valve clearance		155 (250)	Adjust intake and exhaust valve clearance after 750 km break-in period

MAINTENANCE

Item		Maintenance Schedule Key ▶ ■ ◆ - See page 125		
		Calendar-based Maintenance Interval (service whichever interval comes first)		
		CALENDAR	Miles (Km)	Remarks
	Brake pad wear	Monthly	62 (100)	Inspect
	Battery	Monthly	124 (200)	Check terminals; clean; test
▶	Front gear case oil	Monthly	155 (250)	Inspect level; Change yearly
▶	Rear gear case oil	Monthly	155 (250)	Inspect level; Change yearly
▶	Engine oil	Monthly	155 (250)	Inspect level; Change yearly
	Gearshift	Monthly	310 (500)	Inspect; Lubricate; Adjust
▶	General lubrication	3M	310 (500)	Lubricate all fittings, pivots, cables, etc.
■	Steering knuckle	6M	310 (500)	Inspect
■	Steering handlebar	6M	310 (500)	Inspect
▶	Front suspension	6M	310 (500)	Lubricate
▶	Rear suspension	6M	310 (500)	Lubricate

MAINTENANCE

Item		Maintenance Schedule Key ► ■ ◆ - See page 125		
		Calendar-based Maintenance Interval (service whichever interval comes first)		
		CALENDAR	Miles (Km)	Remarks
■	Throttle cable	6M	310 (500)	Inspect; Adjust; Lubricate; Replace if necessary
◆	Air filter element		932 (1500)	Replace every 1500km depending on condition Initial inspection; 750km; Do not clean main filter element.
■	CVT drive belt		932 (1500)	Inspect; Replace if necessary. Replace every 3000km or 1 year
■	Cooling system		932 (1500)	Inspect coolant strength seasonally; Pressure test system yearly; Replace every 6000km or 2 years
►	Engine / Transmission oil Change –normal service	12M	1864 (3000)	Perform break-in oil change at 750km
►◆	Fuel hoses	12M	621 (1000)	Inspect routing, condition
■◆	Engine valve clearance	12M	1864 (3000)	Inspect ; Adjust as necessary Initial: 750km

MAINTENANCE

Item		Maintenance Schedule Key ▶ ■ ◆ - See page 125		
		Calendar-based Maintenance Interval (service whichever interval comes first)		
		CALENDAR	Miles (Km)	Remarks
■ ◆	Fuel system	12M	621 (1000)	Inspect fill cap, fuel pump, and fuel pump relay
▶	Oil and filter change	12M	1864 (3000)	Change oil more often in severe use conditions
▶	Cooling hoses	12M	621 (1000)	Inspect ; Initial: 300km
▶	Engine mounts	12M	1864 (3000)	Inspect. Initial: 300km
	Exhaust pipe and muffler	12M	621 (1000)	Inspect; Clean spark arrestor
	Ignition coil	12M	621 (1000)	Inspect connections
	ECU	12M	621 (1000)	Inspect connections
	Wiring and cables	12M	621 (1000)	Inspect for wear, routing, security; check internally if subjected to water, mud, etc.
■	Clutches(primary and secondary pulleys)	12M	1864 (3000)	Inspect; clean; replace worn parts

MAINTENANCE

Item		Maintenance Schedule Key ► ■ ◆ - See page 125		
		Calendar-based Maintenance Interval (service whichever interval comes first)		
		CALENDAR	Miles (Km)	Remarks
	Wheel bearings	12M	994 (1600)	Inspect and replace as necessary
◆	Spark plug	12M	1864 (3000)	Initial inspection:750 km Replace every 6000km
■	Brake fluid	24M	1242 (2000)	Change fluid
►	Radiator	24M	1864 (3000)	Change fluid; clean external surfaces regularly
	Engine Idle condition			Inspect =1300 ±100rpm
■	Steering toe adjustment			Inspect periodically; Adjust when parts are replaced
■	Foot brake			Inspect daily; Adjust as necessary
	Headlight aim			Adjust as necessary

MAINTENANCE

Inspection and Service Record

INSPECTION AND SERVICE RECORD	SERVICE MUST BE CARRIED OUT ACCORDING TO THE MAINTENANCE SCHEDULE					
Inspection Number	1	2	3	4	5	6
Date						
Miles / Km						
Dealer Stamp and/or Signature						

MAINTENANCE

INSPECTION AND SERVICE RECORD	SERVICE MUST BE CARRIED OUT ACCORDING TO THE MAINTENANCE SCHEDULE					
Inspection Number	7	8	9	10	11	12
Date						
Miles / Km						
Dealer Stamp and/or Signature						

Maintenance Procedures

Air filter

Check and change the air filter at the intervals outlined in the Maintenance Schedule. The air filter element should be cleaned or replaced more often if the vehicle is used in extremely dusty or wet areas. Each time air filter maintenance is performed, check the air inlet of the air filter box for obstructions and debris. Check the air filter housing rubber joint to the throttle body and manifold fittings for an airtight seal. Check that all fittings are secure to avoid the possibility of unfiltered air entering the engine.

Air filter housing inspection

There is a check hose ① at the bottom of the air filter housing. If dust or water can be viewed in this hose, empty the hose and clean the air filter housing thoroughly. If the vehicle was submerged, please contact your local dealer to check for water inside the engine crankcase.

NOTE:

If a large amount of water is present in the air filter, have your dealer check for water entering the engine crankcase.

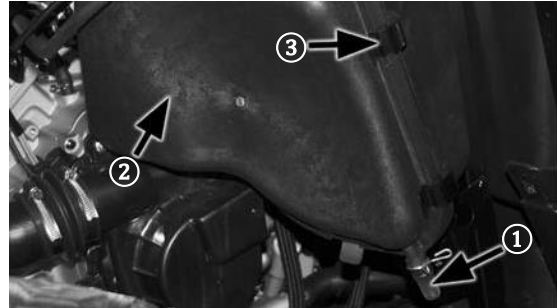

MAINTENANCE

Air filter maintenance

1. Remove the cover panel, located in the right rear fender well.
2. Remove the cover spring clips (2) and remove the filter housing cover (3).
3. Loosen the air filter clamp (4) and remove the air filter (5).
4. Remove the foam pre-filter (6) from the air filter.
5. Wash the foam pre-filter gently with soap and water, and allow it to completely dry.
6. Inspect the paper air filter and verify it is okay to reinstall. Softly brush off accumulated dust if necessary. Install a new filter as necessary.

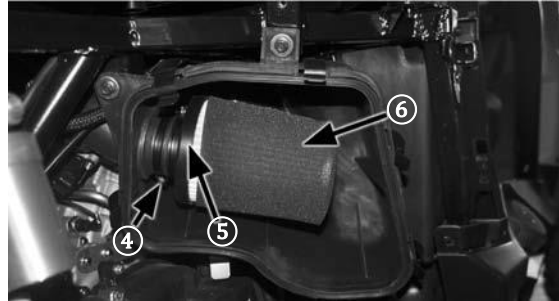

NOTE:

Do not wash paper air filters, or use compressed air to clean the paper filter media.

7. Install the pre-filter onto the air filter. Apply a thin film of lubricant on the inside diameter of the air filter rubber seal.
8. Install the air filter and clamp onto the air filter housing inlet. Tighten the clamp securely.
9. Reinstall the air filter housing cover and spring clips. Verify the cover is installed correctly and is sealing properly.

MAINTENANCE

Drying the air filter housing after submersion

If water has been ingested into the air filter housing, Drain the air filter housing, remove the air filter, and thoroughly dry the components. Do not use compressed air on the paper air filter. Contact your dealer if vehicle performance issues exist.

CAUTION

Do not operate the engine without an air filter element. Unfiltered air entering into the engine can cause engine wear and damage. Driving without an air filter will also decrease performance and can lead to engine overheating.

CAUTION

Major engine damage can result if the vehicle if water has been ingested into the air filter housing, and engine. Have the vehicle serviced by your dealer promptly if your vehicle becomes immersed or stalls in water that exceeds the footrest level. It is important to contact your dealer for service before starting the engine, as water may have been ingested in the air box and engine.

MAINTENANCE

Engine oil – 500/800 only

Always check and change the engine oil at the intervals outlined in the Maintenance Schedule. Change oil more frequently under severe use conditions.

Oil level check (500/800)

1. Place the vehicle on a level surface.
2. Start the engine and let it idle for 20~30 seconds. Stop the engine and wait a short time for the oil to settle.
3. Remove the passenger seat to gain access to the inspection cover ①.
4. Remove the inspection cover by grasping the center hole and pulling firmly.
5. Unscrew the oil dipstick ②, remove it, and wipe off with a clean cloth (*500 engine shown*).
6. Insert the dipstick into the oil filler hole. Do not fully reinstall it.
7. Remove the dipstick and check the oil level indication. Maintain the oil level between the upper and lower indicators.
8. Reinstall the dipstick into the oil filler hole, and hand-tighten it.
9. Reinstall the inspection cover and passenger seat.

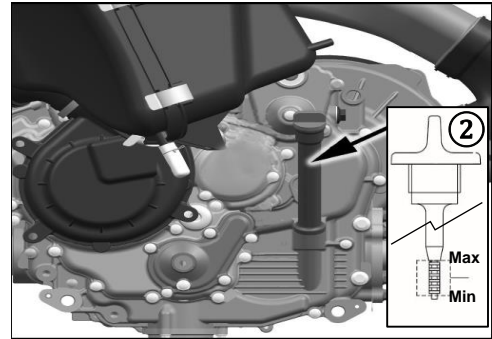
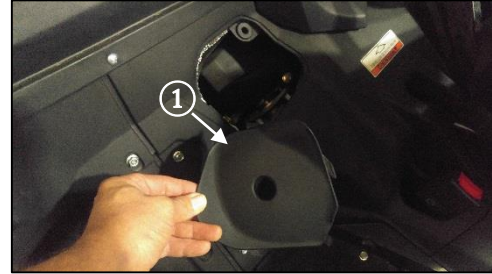

NOTE:

Cover grommet may come loose. Ensure it is in place before reinstalling the cover.

MAINTENANCE

Oil and filter change (500/800)

1. Place the vehicle on a level surface.
2. If the engine was running, wait a sufficient amount of time for the oil to settle and cool.
3. Place an oil pan under the engine to collect the used oil.
4. **800-** Remove the passenger seat and inspection cover to access the oil drain bolt, fill, and filter location.
5. **500-** Remove the passenger seat and inspection cover to access the oil fill location.
6. **800-** Remove the engine oil drain bolt (A) and drain the oil from the crankcase.
7. **500-** Remove the engine oil drain bolt (B) from the bottom of the crankcase and drain the oil.
8. **800/500-** Place a new sealing washer (C) on the drain bolt, then assemble and tighten the drain bolt to **22 ft-lb. (30 Nm)**.

NOTE:

The 500 engine has an internal sump strainer behind a cover that can be checked and cleaned during an oil change. The 800 engine internal sump strainer is not serviceable.

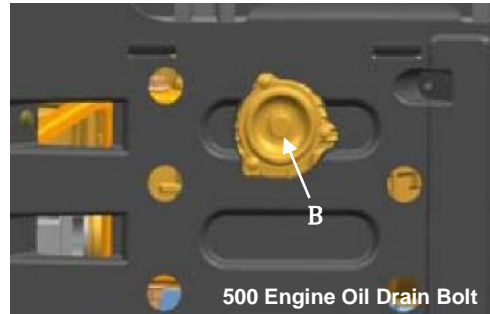
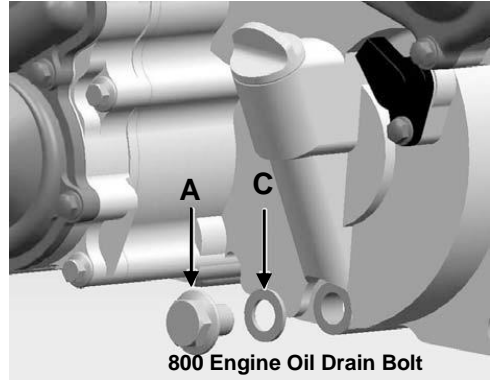

MAINTENANCE

9. Remove the oil filter cover fasteners (4) and cover (5) from the crankcase.
10. Remove the oil filter cartridge (6) from the crankcase housing.
11. Install a new oil filter cartridge in the crankcase housing.
12. Inspect and verify the cover O-ring (7) is okay to reuse, and then install it into the groove of the crankcase housing correctly.
13. Install the oil filter cover and fasteners. Tighten the fasteners to **7.3 ft-lb. (10 Nm)**.
14. Add the specified amount of recommended engine oil, and then reinstall the engine oil dipstick and hand-tighten it.

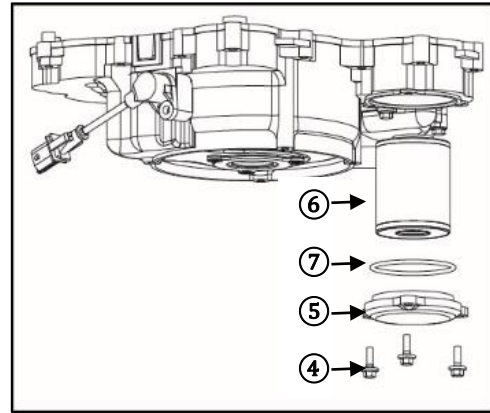

NOTE:

All engines- Engine oil type – SAE 15-40W/SG Oil change with oil filter: **3.06 qt. (2.9 L)**
Maintain the oil level between the upper and lower indicators.

The 800 engine contains a wet clutch assembly, which requires the use of JASO-certified engine oil. To avoid damage to the wet clutch, always use JASO-certified engine oil, commonly sold as motorcycle engine oil.

15. Start the engine and allow it to run for 2-3 minutes. While the engine is running, check for oil leaks. If an oil leak is found, turn the engine off immediately and check for the cause.
16. Turn the engine off. Recheck the oil level and correct it if necessary.

MAINTENANCE

Engine oil - 1000 engine only

NOTE:

The 1000 engine has separate engine and transmission oil drain / fill locations. It also has an internal sump strainer behind a cover that can be checked and cleaned during an oil change.

Oil level check (1000)

1. Place the vehicle on a level surface.
2. If the engine was running, wait a sufficient amount of time for the oil to settle and cool.
3. Unscrew the transmission oil dipstick ②, remove it, and wipe off with a clean cloth.
4. Insert the dipstick into the oil filler hole. Do not fully reinstall it.
5. Remove the dipstick and check the oil level indication. Maintain the oil level between the upper and lower indicators.
6. Reinstall the dipstick into the oil filler hole, and hand-tighten it.

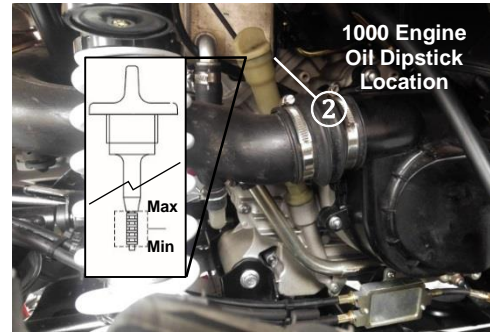

Oil and filter change (1000)

1. Place the vehicle on a level surface.
2. If the engine was running, wait a sufficient amount of time for the oil to settle and cool.
3. Place an oil pan under the engine to collect the used oil.
4. Remove the engine oil drain bolt from the bottom of the crankcase and drain the oil.
5. Place a new sealing washer on the drain bolt, then assemble and tighten the drain bolt to **22 ft-lb. (30 Nm)**.

MAINTENANCE

6. Remove the oil filter cover fasteners (4) and cover (5) from the crankcase.
7. Remove the oil filter cartridge (6) from the crankcase housing.
8. Install a new oil filter cartridge in the crankcase housing.
9. Inspect and verify the cover O-ring (7) is okay to reuse, and then install it into the groove of the crankcase housing correctly.
10. Install the oil filter cover and fasteners. Tighten the fasteners to **7.3 ft-lb. (10 Nm)**.
11. Add the specified amount of recommended engine oil, and then reinstall the engine oil dipstick and hand-tighten it.

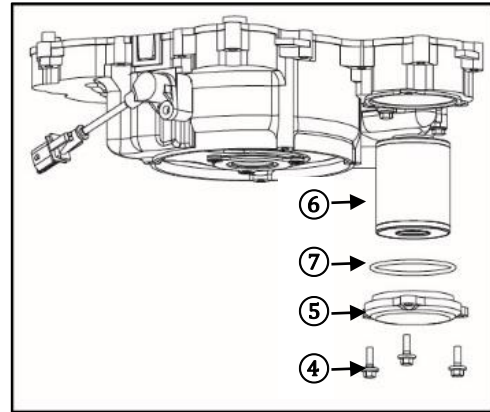

NOTE:

All engines- Engine oil type – SAE 15-40W/SG Oil change with oil filter: **3.06 qt. (2.9 L)**
Maintain the oil level between the upper and lower indicators.

12. Start the engine and allow it to run for 2-3 minutes. While the engine is running, check for oil leaks. If an oil leak is found, turn the engine off immediately and check for the cause.
13. Turn the engine off. Recheck the oil level and correct it if necessary.

Transmission oil - 1000 engine only

Oil level check (1000)

1. Place the vehicle on a level surface.
2. If the engine was running, wait a sufficient amount of time for the oil to settle and cool.
3. Unscrew the transmission oil dipstick (2), remove it, and wipe off with a clean cloth.
4. Insert the dipstick into the oil filler hole. Do not fully reinstall it.
5. Remove the dipstick and check the oil level indication. Maintain the oil level between the upper and lower indicators.
6. Reinstall the dipstick into the oil filler hole, and hand-tighten it.

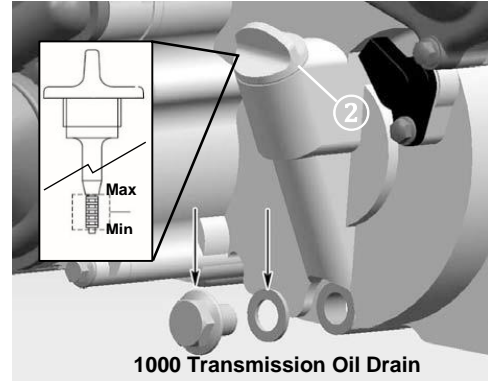

Oil change (1000)

1. Place the vehicle on a level surface.
2. If the engine was running, wait a sufficient amount of time for the oil to settle and cool.
3. Place an oil pan under the engine to collect the used oil.
4. Remove the transmission oil drain bolt at the bottom of the oil fill location and drain the oil.
5. Place a new sealing washer on the drain bolt, then assemble and tighten the drain bolt to **22 ft-lb. (30 Nm)**.
6. Add the specified amount of recommended transmission oil, and then reinstall the transmission oil dipstick and hand-tighten it.

NOTE: Transmission oil type – SAE 15-40W/SG or 80W-90 GL-5 **Capacity** - 20 oz. (0.6L)

MAINTENANCE

Engine valve clearance adjustment

The intake and exhaust valve clearances change with use of the vehicle, which can result in improper fuel/air supply or engine noise. To prevent this, the valve clearances must be adjusted according to the maintenance schedule. This adjustment should be performed by a professional service technician. Contact your dealer for service.

NOTE: (all engines)

Intake valve clearance (cold engine): **.003~.005 in. (0.08~0.12mm)**

Exhaust valve clearance (cold engine): **.005~.007 in. (0.12~0.18mm)**

Engine Idle Speed

This vehicle is equipped with an electronic fuel injection system. The throttle body is a vital part of the fuel system which requires very sophisticated adjustment, and was set at the factory. There are no consumer provisions to adjust engine idle speed. If the settings are disturbed, poor engine performance and damage may result. Check the engine idle speed for stability or an abnormal engine idle condition and contact your dealer for service if necessary.

NOTE:

1000/800 - Engine idle speed: **1300 ±100 rpm** (engine at operating temperature)

500 - Engine idle speed: **1500 ±150 rpm** (engine at operating temperature)

MAINTENANCE

Front and rear gear case

The front and rear gear case must be checked for oil leaks before operating. If any leaks are found, have your dealer check and repair the vehicle.

Front gear case oil check

1. Place the vehicle on a level surface.
2. Remove the oil filler bolt ① and check the oil level. The level should be up to the brim of the hole. If the level is low, add sufficient oil to raise it to the specified level.
3. Install the oil filler bolt and tighten it to **17 ft-lb. (23 Nm)**.

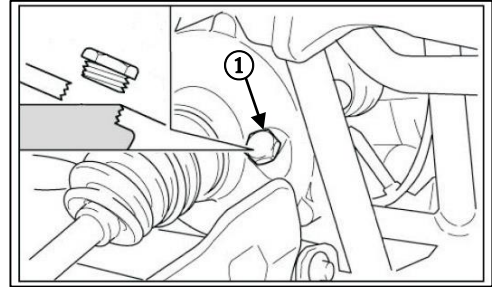

MAINTENANCE

Front gear case oil change

4. Place the vehicle on a level surface.
5. Place an oil pan under the gear case to collect the used oil.
6. Remove the oil drain bolt (2) at the bottom of the gear case and drain the oil.
7. Install the oil drain bolt and tighten it to **17 ft-lb. (23 Nm)**.
8. Remove the oil filler bolt. Add sufficient oil to raise the level up to the brim of the hole.
9. Install the oil filler bolt and tighten it to **17 ft-lb. (23 Nm)**.

NOTE:

Approximate front gear case oil capacity: **9.5 oz. (280 ml)**

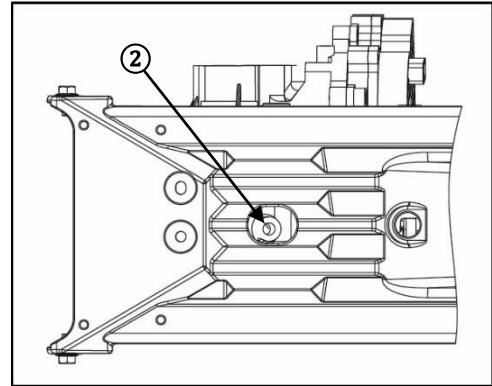

Rear gear case oil check

1. Place the vehicle on a level surface.
2. Remove the oil filler bolt (3) and check the oil level. The level should be up to the brim of the hole. If the level is low, add sufficient oil to raise it to the specified level.
3. Install the oil filler bolt and tighten it to **17 ft-lb. (23 Nm)**.

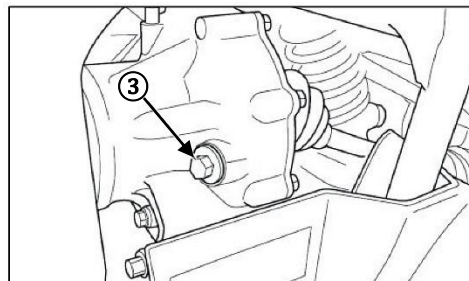

Rear gear case oil change

1. Place the vehicle on a level surface.
2. Place an oil pan under the gear case to collect the used oil.
3. Remove the oil drain bolt (4) at the bottom of the gear case and drain the oil.
4. Install the oil drain bolt and tighten it to **17 ft-lb. (23 Nm)**.
5. Add sufficient oil to raise the level up to the brim of the hole.
6. Install the oil filler bolt and tighten it to **17 ft-lb. (23 Nm)**.

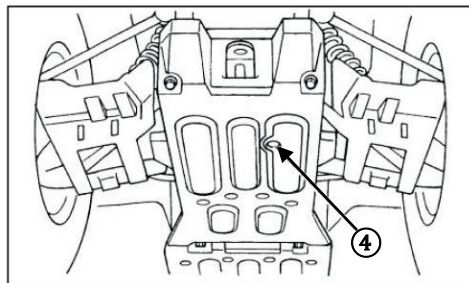

NOTE:

Approximate rear gear case oil capacity: **7.0 oz. (250ml)**

MAINTENANCE

Front and rear axle boots ①

The front and rear axle boots ① must be checked for holes or wear before operating. If any damage is found, have your dealer repair the vehicle.

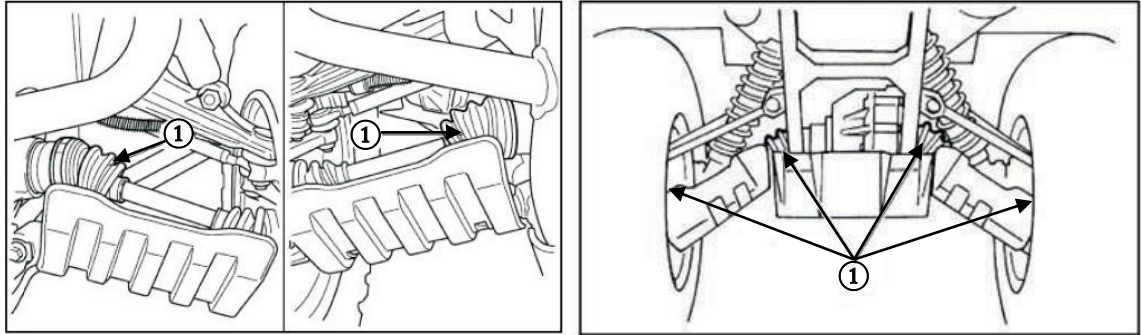

CVT System

This vehicle has a Continuously Variable Transmission (CVT) system that utilizes a drive belt and clutch pulleys to automatically vary transmission drive ratios, allowing infinite variability between the highest and lowest vehicle speeds with no discrete steps or shifts.

The CVT system consists of a primary clutch ①, which is an advanced form of centrifugal clutch that is mounted to the engine crankshaft (A). If equipped, the primary clutch may also contain a one-way bearing that creates an engine braking feature to slow the vehicle without having to use the brakes.

The secondary clutch ② is mounted to the input shaft of the transmission (B) and serves two functions; As a “slave” pulley to the primary clutch, and to provide a torque sensing element that shifts drive ratios.

The drive belt ③ is a heavy duty V-belt that connects the engine and transmission clutch pulleys.

A CVT housing and cover encloses the clutches and belt assembly. There are inlet and outlet cooling ducts that route air to cool the components, and they should be regularly inspected. The CVT components do not contain any user maintenance items. Contact your dealer for service.

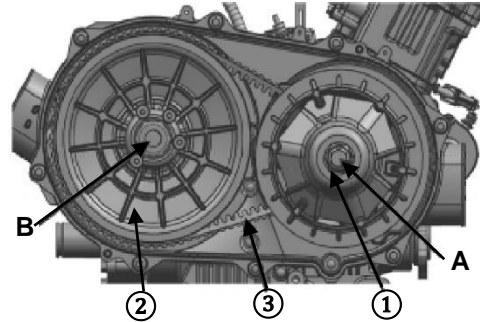

MAINTENANCE

Avoiding CVT drive belt and clutch failures

CVT clutch and belt life can be dramatically extended by avoiding these common operating mistakes:

Causes CVT damage:	Solution:
Attempting to load the vehicle onto a truck bed or tall trailer in high gear.	Shift transmission to low gear during loading of the vehicle to prevent belt burning.
Starting out on a steep incline in high gear.	When starting out on steep inclines, use low gear.
Constant driving at low RPM, driving at just above clutch engagement RPM, or at low speed (approximately 3-6 mph [5-10 km/h]) in high gear.	Low gear is highly recommended for cooler CVT operating temperatures and longer component life. Drive at a higher speed or use low gear more frequently.
Insufficient warm-up of CVT exposed to low ambient temperatures	Warm the engine before driving, the CVT drive belt will become more flexible and prevent belt burning.
Slow throttle and easy CVT engagement.	Use the throttle with purpose and effectively for efficient CVT clutch engagement.
Towing/pushing at low RPM/low ground speed.	Use low gear only.
Utility use/plowing snow, dirt, etc.	Use low gear only.
Heavy vehicle load operating at low speed	Use low gear only.

MAINTENANCE

Causes CVT damage:	Solution
Stuck in mud or snow.	Shift the transmission to low gear, and carefully use fast, aggressive throttle application to engage CVT. WARNING: Excessive throttle may cause loss of control and vehicle overturn.
Climbing over large objects from a stopped position.	Shift the transmission to low gear, and carefully use fast, brief, aggressive throttle application to engage the CVT. WARNING: Excessive throttle may cause loss of control and vehicle overturn.
Belt slipping from water or snow ingestion into the CVT system.	Drain the water from the CVT housing and dry the CVT if possible, or contact your dealer.
Overheating of the CVT components causes malfunction.	Contact your dealer for inspection and repair of the CVT components.

CVT air outlet check hose

There is a check hose ④ at the bottom of the CVT cooling outlet duct, located at the rear of the engine. If dust or water can be viewed in this hose, empty the hose and clean or drain the CVT housing. If the vehicle was submerged, contact your local dealer to check the CVT housing and components thoroughly.

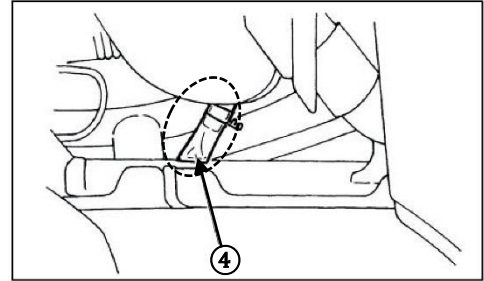

What to do if water collects in the CVT housing

If the vehicle was submerged in water deep enough that water has entered the CVT housing, remove the drain bolt ⑤ at the bottom of the housing to drain the water from the case.

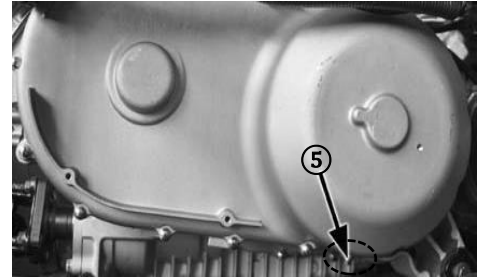

CAUTION

If water drains from the CVT housing after removing the bolt, have your dealer inspect the vehicle, as water may have affected the CVT system and other engine parts

Drying a wet CVT system

If the CVT system was submerged and the drive belt is slipping, any remaining moisture inside the CVT housing after draining can be expelled by running the engine above 2000 RPM in Park or Neutral for 30-60 seconds, then testing for proper CVT function in low gear. Repeat as necessary. If the CVT system continues to slip or have poor performance, contact your dealer.

Cooling system

Coolant level inspection

1. Place the vehicle on a level surface.
2. Inspect the coolant level in the reservoir ①, which can be viewed through the left side inner fender area.
3. If the coolant is at or below the lower limit mark; remove the access cover and the reservoir cap ②. Add coolant to the upper limit mark, install the reservoir cap, and then reinstall the access cover.

NOTE:

Check the coolant level in the coolant reservoir when the engine is cold, as the coolant level will vary with engine temperature.

Coolant system capacity: **3.1 qt. (3.0 L)**

Lowest capacity of coolant reservoir: **0.24 qt. (230 ml)**

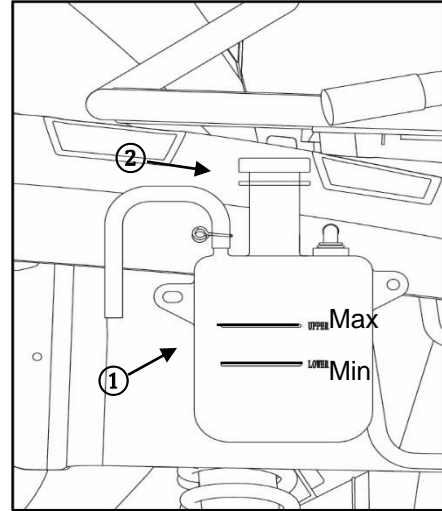

CAUTION

If water is added, have your dealer check the antifreeze content of the coolant as soon as possible. Never add hard water or salt water, as it is harmful to the engine. Softened tap water may be used if distilled water is not available. The radiator fan operation is automatically switched on or off according to the coolant temperature in the radiator during operation.

Change the coolant

CAUTION

After running the engine, never remove the radiator cap immediately. Wait for the engine to cool down before removing the radiator cap. Hot coolant can cause serious burns.

1. Place the vehicle on a level surface.
2. Remove the front access cover.
3. Remove the radiator cap ③.
4. Remove the coolant reservoir cap ④.

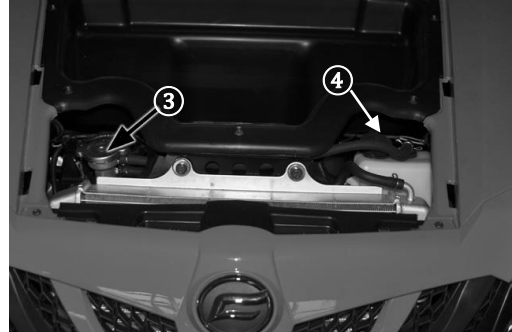

MAINTENANCE

5. Place a container under the engine, and then remove the coolant drain bolt (5).
6. Disconnect the hose from the coolant reservoir, and drain the coolant into a container.
7. After draining the system, thoroughly flush the system with clean tap water. Allow the water to drain completely.
8. Replace the coolant drain bolt washer if it is damaged, then install and tighten the coolant drain bolt, but do not torque to specification.
9. Reinstall the coolant reservoir hose.
10. Fill the recommended coolant into the radiator until it is full.

NOTE:

When filling coolant, at the same time loosen the coolant drain bolt (5) to draw out potential air bubbles inside the coolant hose until coolant flows out, then tighten the drain bolt to **7.3 ft-lb. (10 Nm)**.

11. Install the radiator cap.
12. Start the engine and let it idle for several minutes. Stop the engine and allow it to cool. Check the coolant level in the radiator. If it is low, add more coolant until it reaches the top of the radiator. Repeat as necessary.

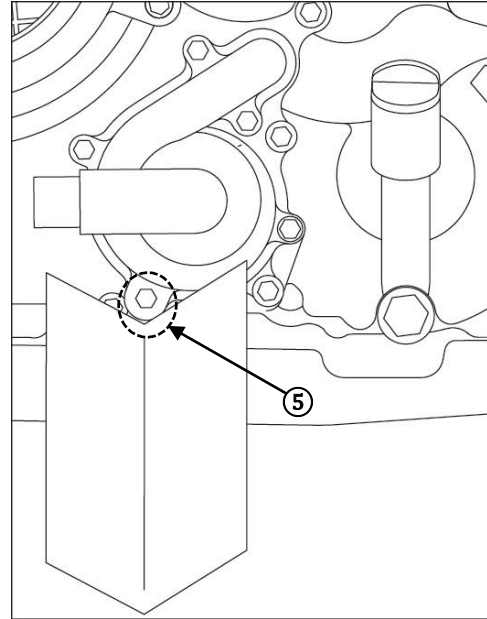

MAINTENANCE

13. Fill the coolant reservoir with coolant up to the upper limit.
14. Install the coolant reservoir cap and check for coolant leaks. If any leaks are found, have your dealer check the cooling system.
15. Reinstall the front access cover.

NOTE:

Recommended antifreeze:

Any high quality ethylene glycol antifreeze containing corrosion inhibitors for aluminum engines.

Antifreeze and water mixing ratio: **1:1**

Coolant capacity: **3.1 qt. (3.0 L)**

Coolant change: **3.0 qt. (2.8 L)**

Coolant reservoir capacity: **0.4~0.6 qt. (380~600ml)**

Cleaning the Radiator

Cleaning the external surfaces of the radiator if it is covered with mud or debris will ensure it continues to efficiently cool the engine. Use only low pressure water to clean the radiator. High pressure washers can damage components. Ensure that water can flow freely through the radiator fins. This is a sign that cooling air will be allowed to pass through.

MAINTENANCE

Spark plug(s)

The spark plug is an important engine component that is easy to inspect. The color and condition of the spark plug can indicate the condition of the engine. The ideal color on the insulator around the center electrode is a medium-to-light tan color for an engine that is being operated normally. If electrode erosion becomes excessive, or if carbon and other deposits are excessive, you should replace the spark plug with the specified plug.

Periodically remove and inspect the spark plug(s) for heat damage and deposits that will cause them to break down and erode. Do not attempt to diagnose spark plug color or engine problems yourself. Instead, take the vehicle to your dealer for service.

Spark Plug Removal and Inspection

1. Remove the cargo box access panel:
 - Remove the 10mm retaining bolt using a wrench from the tool kit.
 - Pull up on the rear of the access panel and remove it from the cargo box.
2. Clean any dirt or debris from the spark plug and cylinder area.
3. Remove the spark plug cap ①.



MAINTENANCE

4. Use the spark plug socket and wrench ② from the tool kit to remove the spark plug.
5. Check the spark plug gap (A) using a thickness gauge. Adjust the gap if necessary.

NOTE:

Specified spark plug: **DCPR8E (NGK)**

Spark plug gap: **.035~.045 in. (0.8~0.9 mm)**

6. Clean the gasket surface. Wipe off any grime from the threads.
7. Install spark plug and tighten to specified torque.

NOTE:

Spark plug torque: **14.8 ft-lb. (20 Nm)**. If a torque wrench is not available when you are installing a spark plug, a good estimate of the correct torque is 1/4 to 1/2 turn past finger tight.

8. Install the spark plug cap.
9. Install the cargo box access panel. Torque the fasteners to **7.3 ft-lb. (10 Nm)**.

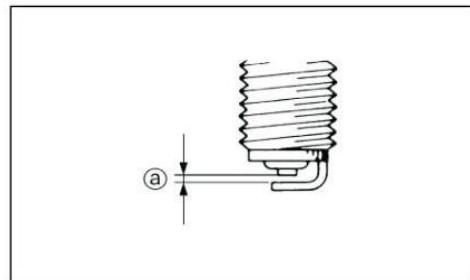
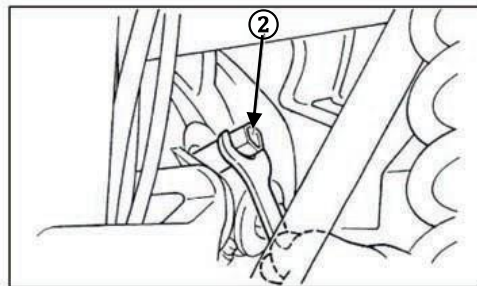

MAINTENANCE

Spark plug removal to expel water from the engine

If water has been ingested into the engine, it is important to remove the water as soon as possible by removing the spark plug(s) and using the starter system to rotate the engine for a short period to expel water out of the cylinder(s). Verify that the air box has been drained of water before attempting to expel water. Have a dealer service the engine immediately.

CAUTION

Major engine damage can result if the vehicle if water is ingested into the engine. Have the vehicle serviced by your dealer promptly if your vehicle becomes immersed or stalls in water that exceeds the footrest level. It is important to contact your dealer for service before starting the engine if water has been ingested. Water inside the engine can cause a 'hydraulic lock' effect that can damage the starter and engine components. The engine oil should be checked for water contamination. Drain and refill with new engine oil if water is found in the crankcase.

MAINTENANCE

Exhaust spark arrester

Clean carbon deposits from the spark arrester periodically while the muffler and exhaust are at normal air temperature.

CAUTION

Ensure that the exhaust pipe and muffler are fully cooled down before servicing the spark arrester.

1. Remove the fasteners ①.
2. Tap the tailpipe lightly to loosen it and remove the spark arrester ② from the muffler.
3. Use a wire brush to remove any carbon deposits from the spark arrester portion of the tailpipe ③.
4. Insert the tailpipe into the muffler and align the bolt holes.
5. Install and torque the fasteners to **7.3 ft-lb. (10 Nm)**.

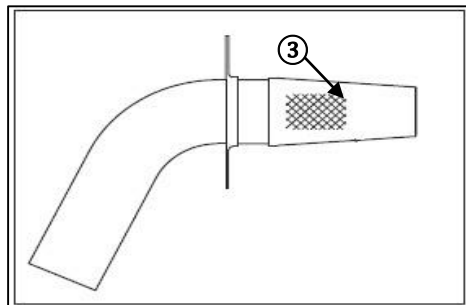
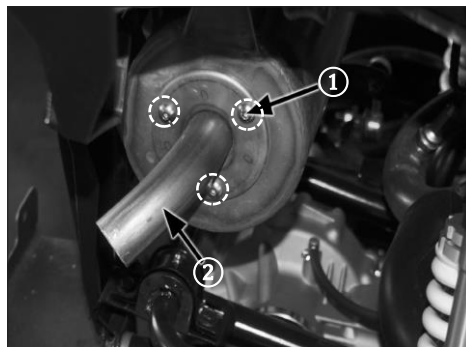

MAINTENANCE

Battery

This vehicle is equipped with a 12 volt/30 Amp-hour, sealed low-maintenance battery, which is located behind the left rear cover panel. Therefore, it is not necessary to check the electrolyte or add distilled water to the battery. If the battery seems to have discharged, consult your dealer. Verify that the battery connections are clean and secured during routine maintenance.

Battery maintenance guidelines:

- If the vehicle will not be used for a month or longer, remove the battery and store it in a cool, dry place. Completely recharge the battery before reinstallation.
- A special battery charger (constant low voltage/ampere) is required for recharging low-maintenance batteries. Using a conventional battery charger may shorten the battery life.
- Always make sure the cable connections are the correct polarity when reinstalling the battery. RED ('+' positive) / Black ('-' negative). Always disconnect the RED ('+' positive) cable last during removal, and reconnect it first during installation.
- Corroded battery connections can be cleaned with a mixture of baking soda and water.

WARNING

Avoid contact with skin, eyes or clothing, and always shield eyes when working near batteries. Keep out of reach of children. Keep batteries away from sparks, flames, cigarettes or other sources of ignition. Ventilate the area when charging or using in a closed space.

Battery acid antidote:

EXTERNAL: Flush with water.

INTERNAL: Get prompt medical attention.

EYES: Flush with water for 15 minutes and get prompt medical attention.

Brakes

Brake fluid level inspection

Before riding, check that the brake fluid level is above the low mark and replenish whenever necessary. Insufficient brake fluid may let air enter the brake system, possibly causing the brakes to become ineffective. The brake fluid master cylinder reservoir levels (A) can be viewed from the left side inner fender well.

Observe these precautions:

- When checking the fluid level, make sure the vehicle is on a level surface.
- Use only the designated quality brake fluid. Otherwise, the rubber seals may deteriorate, causing leaks and poor brake performance.
- Recommended brake fluid: DOT 4.
- Refill with the same type of brake fluid. Mixing fluids may result in a harmful chemical reaction and may lead to poor brake performance.
- Be careful that water does not enter the master cylinder reservoir. Water will significantly lower the boiling point of the fluid and lead to poor brake performance.
- Brake fluid may deteriorate painted surfaces or plastic parts. Always clean up spilled fluid immediately.
- As the brake pads wear, it is normal for the brake fluid level to gradually go down. A low brake fluid level may indicate worn brake pads or brake system leakage; therefore, be sure to check the brake pads for wear and the brake system for leakage.
- Have your dealer check the cause if the brake fluid level goes down unexpectedly.

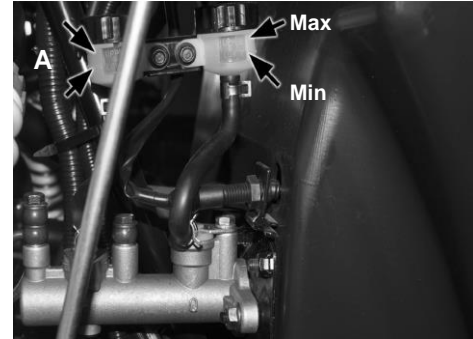

Brake pad inspection

Inspect the front and rear brake pads and discs for damage and wear. If the pad thickness **(A)** is less than **0.059 in. (1.5mm)** or the disc thickness **(B)** is less than **.118 in. (3.0mm)**, have your dealer replace them. Replacement of brake components requires professional knowledge. These procedures should be performed by your dealer.

NOTE:

Wheels must be removed to check brake pads.



CAUTION

After servicing:

- Make sure the brakes operate smoothly and that the lever free play is correct.
- Make sure the brakes do not drag and the brake operation is not spongy.
- All air is bled from the brake system.

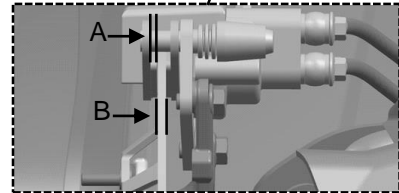

MAINTENANCE

Brake fluid change

Complete brake system fluid replacement should be performed only by trained service personnel. Have your dealer replace the following components during periodic maintenance, or when they are damaged or leaking:

- Replace the seals every two (2) years.
- Replace the brake hoses every four (4) years.

Brake light switch operation

The brake light switch is activated by foot brake pedal pressure, and is properly working when the brake light comes on just as braking takes effect. Check that the switch assembly or the electrical circuit is working properly in case of brake light failure.

Control Cables

Inspection and lubrication

Inspect throttle and brake cables frequently. Lubricate the inner cable and the cable ends. Replace damaged cables when they are discovered. Submersion of the vehicle may cause cables to corrode or stick. If the cables do not operate smoothly, ask your dealer to replace them.

NOTE:

Recommended lubricant: SAE 10W-30 or a commercially available cable lubricant.

MAINTENANCE

Suspension

Some front suspension components of the vehicle do not require maintenance or lubrication. Ensure these components are cleaned regularly, and are not loose or damaged before operating the vehicle.

Pivot Lubrication

Lubricate the upper and lower pivots of the front and rear suspension:

1. Add grease into the upper and lower pivot grease nipples ① located at the frame with a grease gun until grease lightly flows from the bushing.

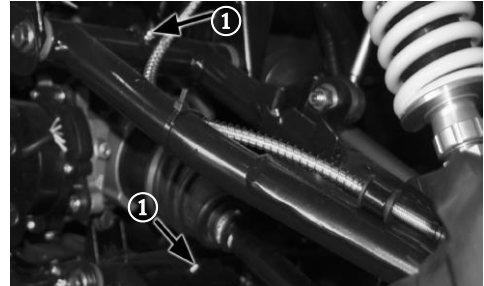

Rear hub carrier lubrication

Lubricate the upper and lower pivots of the rear hub carrier:

1. Remove the rear wheels.
2. Add grease into the hub carrier upper and lower pivot grease nipples ② with a grease gun until grease lightly flows from the bushing.
3. Reinstall the rear wheels. Torque the fasteners to specification.

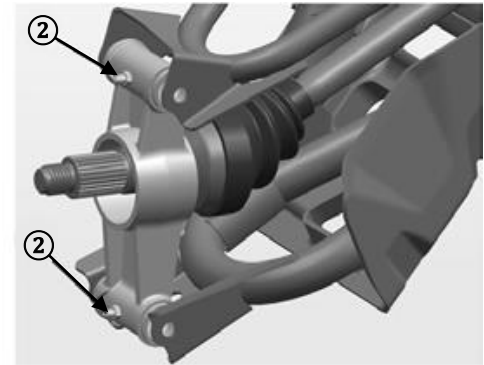

NOTE:

Recommended lubricant: **All Season Grease**

MAINTENANCE

Shock preload and damping adjustment

The front and rear shock spring preload and damping can be adjusted to for rider weight, cargo, and riding conditions. Always adjust the shock absorbers on the left and right side to the same setting.

Adjust the spring preload:

A = Soft ~ B = Hard

- To *increase* the spring preload, loosen the lock nut ② and turn the adjusting ring ③ in direction 'B'.
- To *decrease* the spring preload, loosen the lock nut ② and turn the adjusting ring ③ in direction 'A'.

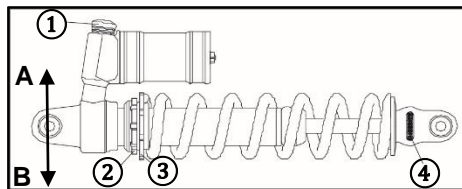

NOTE:

A special collar wrench is included in the tool kit to make spring preload adjustments.

Adjust the shock damping:

Rebound: Turn the adjuster ④ to SLOW side until it stops, then turn to FAST side while checking the damping rebound action of the shock until the performance is satisfactory. Record the number of turns for reference.

Pressure: Turn adjuster ① to HARD side until it stops, then turn to SOFT side while checking the damping pressure action of the shock until the performance is satisfactory. Record the number of turns for reference.

MAINTENANCE

Wheels

Tire pressure

Inspect the tire pressure before operation:

Front: 10.1 psi (70kPa)

Rear: 14.5 psi (100kPa)

Tread depth

Inspect the tread depth regularly and replace the tires if the minimum tread depth is less than:

Minimum tread depth: **3/32 in. (3.0mm)**

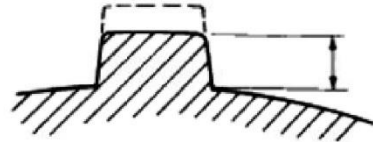
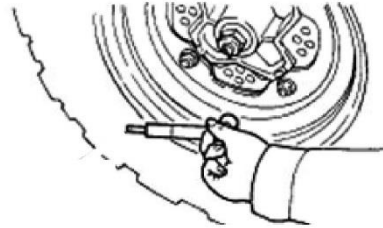

Wheel Bearings

1. Lift the vehicle and support it securely under the frame with the tires off the ground.
2. Push and pull the wheels at the outer edges to feel for side play or looseness. See your dealer if there is any side play or looseness.

Wheel Removal

1. Ensure vehicle is in park.
2. Loosen the wheel fasteners.
3. Elevate the vehicle and place a suitable support stand under the frame.
4. Remove the fasteners from the wheel.
5. Remove the wheel.

Wheel Installation

1. Ensure vehicle is in park.
2. Install the wheel.
3. Install the wheel fasteners hand tight.
4. Elevate the vehicle, remove the support stand under the frame, and lower the vehicle to the ground.
5. Torque the wheel fasteners to specification:
 - Steel wheels - **37~44 ft-lb. (50~60 Nm)**
 - Aluminum wheels - **52~59 ft-lb. (70~80 Nm)**



NOTE:

If aluminum wheels are used with tapered fasteners, install the fastener with the tapered side facing the wheel. For steel wheels, install the fastener with the flat surface facing the wheel.

MAINTENANCE

Electrical

Fuses

The fuses ① are located under the front access cover. If a fuse is blown, turn off the main switch and install a new fuse of the specified amperage. Turn on the main switch. If the fuse immediately blows again, contact your dealer.

Ref	FUSE	RATING
--	Main fuse (Under driver seat)	40A
--	EPS fuse (Under driver seat)	30A
F2	Fuel pump/EFI/ignition power supply/auxiliary starter relay	15A
F3	Turn signal/position light/ dashboard/ horn/diff. gear motor relay	10A
F4	DC outlet/Mp3/Navigation	15A
F5	Headlight	10A
F6	Fan motor	15A
F7	ECU power supply	5A

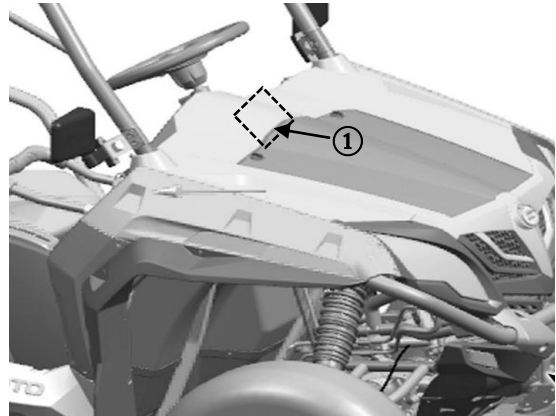

⚠ CAUTION

To prevent an accidental short-circuit, turn off the main switch before checking or replacing fuses. Always use a fuse with the correct specified rating. Never use conductive material in place of the proper fuse. Using an improper fuse can cause damage to the electrical system and may lead to a fire.

MAINTENANCE

Main Fuse and EPS Fuse

The Main fuse and EPS fuse ① are located under the driver's seat access panel. If the fuse is blown, turn off the main switch and install a new fuse of the specified amperage. Turn on the main switch. If the fuse immediately blows again, contact your dealer.



Relays

Electrical relays ② help operate the various vehicle system functions, and are located under the front access cover. Removal of the inner storage compartment is required to gain access. For relay replacement or diagnosis, contact your dealer.

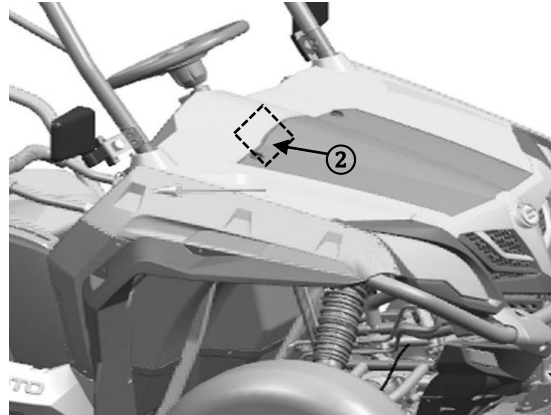

Relay Control Functions:

- | | |
|-----------------|-----------------------|
| High Beam Relay | Low Beam Relay |
| Fan Relay | Fuel Pump Relay |
| 2x4 Relay | 4x4 LOCK Relay |
| Main Relay | Auxiliary Start Relay |
- Flash Relay (if equipped)

Head light adjustment

1. To adjust the head lights:
 - Turn screws ① to adjust the high beam direction beam vertically and horizontally.
 - Turn screw ② to adjust the low beam vertically.

⚠WARNING
It is advisable to have your dealer perform headlight adjustments. Improper adjustment could lead to an accident resulting in serious injury or death.

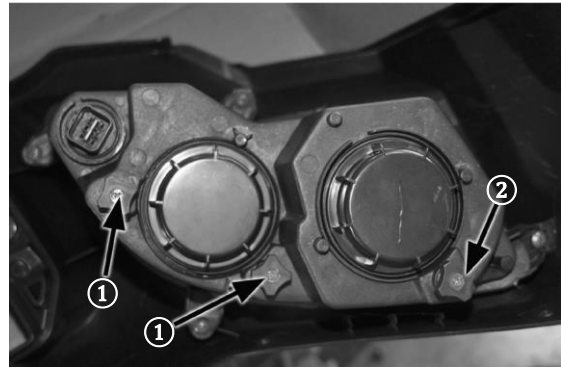

MAINTENANCE

Head light replacement

1. Access the headlight lamp:
 - Remove the cover (2) (3) from the headlight assembly (1) by turning it counter-clockwise.
 - Remove the cover to expose the headlight lamp.
2. Remove the headlight lamp lock spring.
3. Disconnect the failed bulb, pull it out, and replace it with a new bulb.
4. Reinstall the bulb and lock spring into the headlight housing.
5. Reinstall the cover and turn it clockwise.
6. Test the head light and ensure it is working properly.

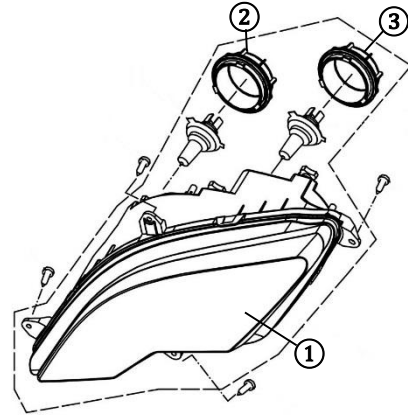

CAUTION

Hot surface. Touch the bulb only after it has cooled down.
Do not touch the bulb surface. Use gloves or other protection to keep oils and dirt off the bulb.

NOTE:

The touring lamp and turning lamp (if equipped) assemblies are an LED structure, which cannot be repaired if damaged or failed. Have your dealer replace the entire assembly if an LED is damaged or has failed.

MAINTENANCE

Tail/brake, position, and turn signal lamp replacement

Brake/tail lights, front position lights, and turn signals (if equipped) are LED type. Have your dealer replace the entire assembly if an LED is damaged or has failed.

License plate lamp replacement

If the license plate lamp has failed:

1. Pull the lamp holder from the rear of the license plate lamp housing.
2. Pull the failed bulb and replace it with a new bulb.
3. Reinstall the lamp holder into the rear of the license plate lamp housing.
4. Bulb Specification: **12V 5W W5W**

 CAUTION
--

Hot surface. Touch the bulb only after it has cooled down. Do not touch the bulb surface.

MAINTENANCE

Cleaning and Storage

Washing the vehicle

Keeping your vehicle clean will not only improve its appearance, but it can also extend the life of various components. With a few precautions, your vehicle can be cleaned much like an automobile:

- The best and safest way to clean your vehicle is with a garden hose and a pail of mild soap and water. Harsh detergents may deteriorate rubber components.
- Use a professional type washing mitten, cleaning the upper body first and the lower parts last.
- Pay special attention that the cooling system radiator and axle boots are thoroughly cleaned of all dirt and debris.
- Rinse with water frequently and dry the vehicle with a chamois to prevent water spots.
- Lubricate all pivot points immediately after washing.
- Allow the engine to run for a while to evaporate any water that may have entered the engine air intake or exhaust system.

CFMOTO does not recommend the use of a high pressure type car wash system for washing your vehicle, as water can be forced past seals and damage decals. If a high pressure system is used, exercise extreme care to avoid water damage to the decals, wheel bearings, transmission seals, body panels, brakes, warning labels, air filter intake system and electrical system. Ensure water is not allowed to enter into the air filter or CVT housing. If warning and safety labels are damaged, contact your dealer for a replacement.

Waxing the vehicle

Your vehicle can be waxed with any non-abrasive automotive paste wax. Avoid the use of harsh cleaners since they can scratch the body finish.

MAINTENANCE

CAUTION

Certain products, including insect repellants and other chemicals, will damage plastic surfaces. Use caution when using these products near plastic surfaces.

Perform repairs

Make necessary repairs to your vehicle before storing to prevent further damage the next time you operate it.

Check the tires

Inspect the tire treads and overall condition. Set the tires to the specified air pressure.

Oil and filter

Warm the engine, then stop the engine and change the oil and filter.

Air filter/ Air box

Inspect and clean or replace air filter. Clean the air box and the sediment tube.

MAINTENANCE

Check fluid levels

Inspect the following fluid levels and change if necessary:

- Front gear case
- Rear gear case
- Brake fluid (change every two years or as required if fluid looks dark or contaminated)
- Coolant (change every two years or as required if coolant looks contaminated)
- Fuel Level (add fuel stabilizer according to the product label directions)

Stabilize the fuel

Fill the fuel tank with fresh fuel that has been treated with fuel stabilizer according to the product label directions. Do not allow untreated fuel to remain in the tank longer than 30 days, as the fuel begins to degrade and can cause damage to the fuel system components.

Battery storage

- Remove the battery from the vehicle and ensure that it is fully charged before placing it in storage. Protect the battery from freezing temperatures, which can damage the battery.

Lubricate

Inspect all cables and lubricate with cable lubricant according to the product label directions. Grease the vehicle lubricating points with all season grease.

MAINTENANCE

'Fog' the engine

1. Remove the cargo box panel to access the spark plug(s).
2. Remove the spark plug(s), rotate the piston to the bottom of its stroke, and pour approximately 2.0 oz. (15~20ml) of SAE 15W~40/SG engine oil into the opening.

NOTE:

Do this carefully! If you miss the spark plug hole, oil will drain from the spark plug cavity, and appear to be an oil leak. To access the spark plug hole, use a section of clean hose and a small plastic squeeze bottle filled with the pre-measured amount of oil.

3. Reinstall the spark plug(s). Torque the spark plug to specification.
4. Turn engine over several times slowly. Oil will be forced in and around the piston, piston rings and the cylinder will be coated with a protective film of fresh oil.
5. Reinstall the spark plug(s), cap(s), and side panel.

NOTE:

Starting the engine during the storage period will disturb the protective film created by fogging. Corrosion could occur. Never start the engine during the storage period.

MAINTENANCE

Storage area and covering

Support the vehicle with stands under the frame with the tires 1/2in (30~40mm) off the ground. Be sure the storage area is well ventilated, and cover the machine with an approved cover.

NOTE:

Do not use covers made of plastic or coated materials. They do not allow enough ventilation to prevent condensation, and may promote corrosion and oxidation.

Transporting the vehicle

Follow these procedures when transporting the vehicle:

- Turn off the engine and remove the key to prevent loss during transporting.
- Ensure the fuel cap is installed correctly and secure.
- Ensure the seat is installed correctly and secure.
- Place the gear into any position except the parking position, and block the front and rear wheels to prevent the vehicle from moving.

CAUTION
Never transport with the gear selector in the parking position. Damage to the engine and transmission may result.

- Secure both the front and rear of the vehicle frame to the transport to prevent the vehicle from sliding or moving.

VEHICLE DIAGNOSIS

Vehicle Issue Diagnosis

This section is intended to guide an average owner to simple items that could cause operating problems. Diagnosis of vehicle issues may require the experience of a dealership technician. Please contact your dealer if a solution is not apparent.

Engine doesn't turn over

Possible Cause	Solution
Blown fuse	Reset or replace the fuse
Low battery voltage	Recharge battery to 12.5 Vdc – Confirm battery state of health
Loose battery connections	Check all connections and tighten if necessary
Loose starter system electrical connections	Check all connections and tighten if necessary
Engine stop switch	Check function
Start circuit not complete – transmission in gear	Press foot brake or shift transmission to neutral or parking position.

Engine pings or knocks

Possible Cause	Solution
Poor quality or low octane fuel	Replace with minimum 89 octane unleaded fuel
Incorrect ignition timing.	See your dealer
Incorrect spark plug gap or heat range	Set spark plug gap to specs or replace plugs

VEHICLE DIAGNOSIS

Engine stops or loses power

Possible Cause	Solution
Overheated engine	Clean radiator screen and external core; clean engine exterior; See your dealer
Out of fuel	Refuel with minimum 89 octane unleaded fuel
Kinked or plugged fuel tank vent line	Inspect and replace; See your dealer
Water present in fuel	Replace with new fuel
Fouled or defective spark plugs	Inspect and clean or replace spark plug
Worn or defective spark plug wires	See your dealer
Incorrect spark plug gap or heat range	Set gap to specs or replace plug
Loose ignition connections	Check all connections and tighten
Low battery voltage	Recharge battery to 12.5 Vdc; check charging system – Confirm battery health
Clogged air filter	Inspect and replace as necessary
Reverse speed limiter malfunction	See your dealer
Electronic throttle control malfunction	See your dealer
Other mechanical failure	See your dealer

Engine turns over, Fails to start

Possible Cause	Solution
Out of Fuel	Refuel
Clogged fuel filter	Inspect and replace as necessary
Water is present in fuel	Replace with 89 minimum octane unleaded fuel
Fuel pump is inoperative	Inspect pump and fuse; Replace as necessary
Old or non-recommended fuel	Replace with 89 minimum octane unleaded fuel

VEHICLE DIAGNOSIS

Possible Cause	Solution
Fouled or defective spark plug(s)	Inspect spark plug(s), replace if necessary
No spark to spark plug	Inspect spark plug(s) , verify stop switch is on
Crankcase filled with water or fuel	Immediately see your dealer
Clogged air filter	Inspect and replace as necessary; Replace spark plugs as necessary
Clogged fuel injector	See your dealer
Low battery voltage	Recharge battery to 12.5 Vdc – Confirm battery health
Mechanical failure	See your dealer

VEHICLE DIAGNOSIS

Engine backfires

Possible Cause	Solution
Weak spark from spark plugs	Inspect and replace spark plugs as necessary
Incorrect spark plug gap or heat range	Set gap to specs or replace plugs
Old or non-recommended fuel	Replace with minimum 89 octane unleaded fuel
Incorrectly installed spark plug wires	See your dealer
Incorrect ignition timing	See your dealer
Mechanical failure	See your dealer
Speed limiter malfunction	See your dealer

Engine runs irregularly, stalls or misfires

Possible Cause	Solution
Fouled or defective spark plugs	Inspect and replace spark plugs as necessary
Worn or defective spark plug wires	See your dealer
Incorrect spark plug gap or heat range	Set gap to specs or replace plugs
Loose electrical connections	Check all connections and tighten
Water present in fuel	Replace with new fuel
Low battery voltage	Recharge battery to 12.5 Vdc; Check charging system
Kinked or plugged fuel tank vent line	Inspect and replace
Incorrect fuel	Replace with 89 minimum octane unleaded fuel
Clogged air filter	Inspect and replace as necessary; Replace spark plugs as necessary
Reverse speed limiter malfunction	See your dealer
Electronic throttle control malfunction	See your dealer

VEHICLE DIAGNOSIS

Possible Cause	Solution
Other mechanical failure	See your dealer
Possible Lean or Rich fuel mixture	See your dealer
Low or contaminated fuel	Add or change fuel, clean the fuel system
Low octane fuel	Replace with minimum 89 octane unleaded fuel
Clogged fuel filter	Replace filter
Fuel is very high octane	Replace with minimum 89 octane unleaded fuel

EFI Malfunction Indicator Light

The fuel injection system on your vehicle contains a self-diagnostic feature that will present a series of 4-digit flashes of the malfunction indicator light (MIL) if it detects a problem. Stop operating the vehicle and contact your dealer immediately if the EFI system MIL is illuminated.

EFI Malfunction Indicator

Example: CODE '0650'

- '0' - light flashes 10 times
- '6' - light flashes 6 times
- '5' - light flashes 5 times
- '0' - light flashes 10 times
-

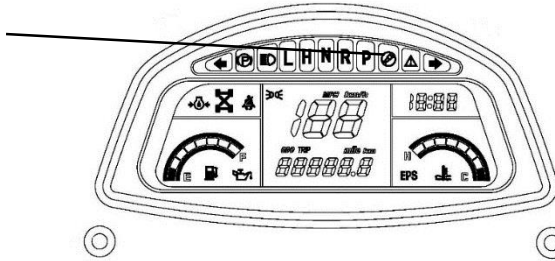

If there are multiple codes detected, the system will wait approximately 3 seconds and display the next code. Any codes displayed will disappear once the problem has been diagnosed and repaired by your dealer.

EPS Malfunction Indicator Light

The Electronic Power Steering system on your vehicle contains a self-diagnostic feature that will illuminate the malfunction indicator light (MIL) if it detects a problem. In normal operation, the EPS indicator will be on after the ignition switch is turned to ON, but EPS will not work. When the engine is started, the EPS indicator will be off and the EPS starts to function.

EPS Malfunction Indicator

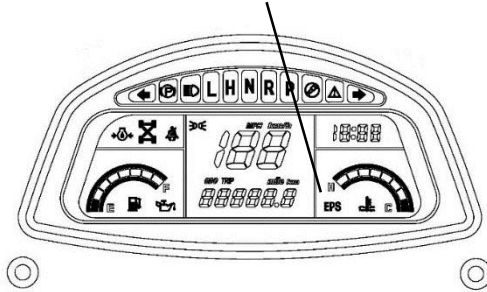

EPS Assembly

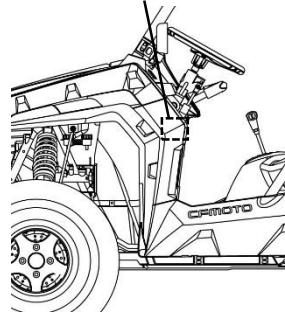

Each trouble code consists of 2 digits, denoted by the times of long flash and short flash of EPS MIL indicator. If there is a failure, the EPS indicator will start to flash. Do NOT switch off the machine. Check the flash sequence of EPS indicator. Write down the flash sequence and contact your dealer for diagnosis.

Times of long flash represent the tens digit.

Times of short flash represent the single digit.

VEHICLE DIAGNOSIS

Duration of long flash: 2 sec.

Duration of short flash: 1 sec.

Flash interval: 1 sec.

The flash cycle will repeat after EPS MIL indicator light turns off for 3 seconds

Stop operating the vehicle and contact your dealer immediately if the EPS system MIL is flashing or there is a loss of steering assist with the engine running.

VEHICLE DIAGNOSIS

Electronic Power Steering (EPS) fault diagnosis and solution

Failure	Probable Reason	Solution
Steering without assistance	<ol style="list-style-type: none"> 1- Wire Connectors have bad contact or are disconnected 2- The fuse blew out 3- Relay damage 4- The controller, motor, or sensor is damaged 	<ol style="list-style-type: none"> 1- Check whether wire connectors and pins are fully inserted 2- Replace the fuse (30A) 3- Contact your dealer 4- Contact your dealer
Power assist doesn't weigh the same for left and right	<ol style="list-style-type: none"> 1- The median output voltage has deviation 2- Controller, motor or sensor is damaged 	<ol style="list-style-type: none"> 1. Contact your dealer 2. Contact your dealer
When system is 'ON', the steering swings to both sides	<ol style="list-style-type: none"> 1. Motor is mounted backwards 2. Controller or sensor is damaged 	<ol style="list-style-type: none"> 1. Contact your dealer 2. Contact your dealer
Steering becomes heavy	<ol style="list-style-type: none"> 1. Battery has power loss 2. Air pressure of the tires (front) is insufficient. 3. Motor damage (power reduction) 	<ol style="list-style-type: none"> 1. Charge the battery 2. Inflate the tires 3. Contact your dealer
System has noise	<ol style="list-style-type: none"> 1. Motor damage 2. Gap of lower steering shaft assembly or mechanical steering assembly is too large 3. Installation of lower steering shaft assembly or mechanical steering assembly is loose 	<ol style="list-style-type: none"> 1. Contact your dealer 2. Contact your dealer 3. Contact your dealer

WARRANTY INFORMATION

Change of Ownership

If you sell your vehicle, any valid remainder of the warranty can be transferred to the new owner. Please record the details of the exchange below and inform an authorized CFMOTO dealer:

Change of Ownership	Original Purchaser	2 nd Owner	3 rd Owner	4 th Owner
Owner Name				
Address				
City				
State / Zip Code				
Telephone				
E-mail				
Date of Purchase				
Odometer Reading				
New Owner Signature				

NOTE:

If a completed Change of Ownership form does not include the required details or are inaccurate, CFMOTO-US reserves the right to investigate the actual ownership of the product, the service history, and possibly refuse the application for warranty transfer if the requirements have not been fulfilled.

WARRANTY INFORMATION

CFMOTO Limited Warranty

Dear Customer,

Thank you for purchasing a CFMOTO product, if any component on your vehicle is found to be defective in materials or workmanship within the terms and conditions of this Limited Warranty, the defective component will be repaired or replaced (at the option of CFMOTO) without charge for parts and/or labor at any authorized dealer located within the United States. The CFMOTO Limited Warranty is subject to the following terms and conditions:

WARRANTY TERMS & CONDITIONS

1. **WARRANTY DURATION:** The duration of the warranty period is one (1) year from the date of the new vehicle purchase from an authorized CFMOTO POWERSPORTS, Inc., Dealer. This warranty coverage is invoked from the purchase and use of CFMOTO vehicles only within the continental United States. During the warranty period, CFMOTO POWERSPORTS, Inc. will cover parts and labor costs incurred by an authorized CFMOTO POWERSPORTS, Inc. Dealer arising from a defect in material and/or workmanship of a CFMOTO vehicle. Any vehicles used for commercial purposes will have their warranty period reduced to six (6) months. If CFMOTO POWERSPORTS, Inc. covers a full engine replacement or a complete vehicle replacement under this warranty, the warranty period does not get extended and remains the same as the original purchase date of the vehicle at issue.

2. **WARRANTY LIMITATIONS:** CFMOTO POWERSPORTS, Inc. provides warranty coverage for one (1) year on all parts and labor for all of its new CFMOTO ATVs. However, the following coverage, exceptions, and limitations apply to all CFMOTO vehicles:

WARRANTY INFORMATION

A. A 30-DAY WARRANTY coverage period applies to all new CFMOTO vehicles in relation to the vehicle's:

- Battery
- Spark Plugs
- Air Filters
- Oil and Fuel Filters

B. A 90-DAY WARRANTY coverage period applies to all new CFMOTO vehicles in relation to the vehicle's:

- Drive Belt
- Gear Shift, CVT, and Wet Clutch
- Throttle and Brake Cables
- Front/Rear Rims
- Front/Rear Tires
- Front/Rear Brake Pads or Shoes
- Front/Rear Brake Discs or Drums
- Wheel or Steering Stem Bearings and Seals
- Rubber Parts/Engine Mounts/Grips/Boots
- Brake or Clutch Levers
- Floor Boards or Pegs
- ATV Winch (if equipped)
- Light Bulbs/Fuses
- Body Plastics and Cosmetic Defects

WARRANTY INFORMATION

3. EXCLUSIONS FROM WARRANTY COVERAGE: Any Damage resulting from the following acts or circumstances is not covered by the CFMOTO POWERSPORTS, Inc., Limited Warranty:

- Fire
- Collision
- Theft
- Unavoidable natural disasters
- Improper storage or transportation
- Failure or negligence in the performance of periodic vehicle maintenance
- Improper or negligent use or operation
- Unauthorized repair or adjustment
- Unauthorized modifications or performance upgrades
- Use of vehicle as a rental vehicle
- Use of vehicle in competitive or racing events

4. VEHICLE CARE AND MAINTENANCE: The vehicle's owner must properly use, maintain, and care for the vehicle as outlined in the CFMOTO POWERSPORTS, Inc., Owner's Manual. Any warranty repairs must be performed exclusively by CFMOTO POWERSPORTS, Inc., authorized Dealers. Any warranty work performed by anyone other than an authorized CFMOTO Dealer will not be covered under the CFMOTO POWERSPORTS, Inc., Limited Warranty policy.

WARRANTY INFORMATION

5. TRANSFER OR CONTINUATION OF WARRANTY: This warranty is transferable only under the following conditions:

- Transfer information must be provided to an authorized CFMOTO POWERSPORTS, Inc. dealer, who will then forward the information to CFMOTO POWERSPORTS, Inc.;
- The complete model and serial number as shown on the original warranty document must be provided.
- The name and address of the existing and new owners must be provided.
- The original delivery date of the vehicle must be provided.
- The new owner must indicate in writing that he/she has received and read the vehicle's Owner's Manual and the CFMOTO POWERSPORTS, Inc. Warranty Policy.

6. WARRANTY REGISTRATION: The Dealer must complete a PDI form and warranty register the vehicle online and provide the completed registration form to CFMOTO POWERSPORTS, Inc., within seven (7) days of completing the sale of the vehicle. Please note that NO warranty claims will be processed unless the product warranty online registration form is completed and the form is received by CFMOTO POWERSPORTS, Inc., from the Dealer.

7. DEALER RESPONSIBILITIES: A CFMOTO authorized Dealer must perform warranty coverage repairs at no charge to the customer, even if they are not the dealer that sold the CFMOTO vehicle to the customer, and must use CFMOTO OEM parts for all warranty repairs. All vehicles sold by the dealer must be inspected and tested by the dealer to ensure proper performance and operation prior to delivery to the customer. No vehicles may be delivered to a customer without first passing a dealer inspection and an operational test.

8. CUSTOMER ASSISTANCE: Any questions regarding your CFMOTO vehicle or related products should be directed to an authorized CFMOTO dealer. However, if a dealer is not available to answer

WARRANTY INFORMATION

customer concerns or address a technical issue with a CFMOTO vehicle or product, CFMOTO POWERSPORTS, Inc., customer representatives can be contacted directly at (763) 398-2690 or by e-mail: info@cfmoto-us.com.

9. **COMMERCIAL USE.** The duration of the warranty for commercial use shall be limited to a period of six (6) months instead of one year for recreational use. All other conditions and limitations shall apply.

10. **TIRES PROVIDED AS ORIGINAL EQUIPMENT:** Other than provided herein, vehicle tires supplied as original equipment are warranted separately by the individual tire manufacturer or its representatives.

11. **DISCLAIMER: NO EXPRESS WARRANTY IS PROVIDED BY CFMOTO POWERSPORTS, INC. WITH RESPECT TO CFMOTO VEHICLES EXCEPT AS SPECIFICALLY SET FORTH HEREIN. ANY IMPLIED WARRANTY, WARRANTY OF MERCHANTABILITY, WARRANTY OF FITNESS FOR A PARTICULAR PURPOSE, AND ALL IMPLIED WARRANTIES ARISING FROM A COURSE OF DEALING, USAGE OF TRADE, BY STATUTE OR OTHERWISE, ARE HEREBY STRICTLY LIMITED TO THE TERMS OF THIS WRITTEN LIMITED WARRANTY.**

12. **INTEGRATION:** This limited warranty supersedes any and all oral, express, or written warranties, statements, or undertakings that may previously have been made, and contains the entire agreement of the parties with respect to the warranty of CFMOTO vehicles. Any and all warranties not contained in this Agreement are specifically excluded. This warranty extends to each original (and subsequent) owner of any CFMOTO ATV, for the term of the original warranty period. This limited warranty shall be the sole and exclusive remedy available to the customer with respect to the covered CFMOTO vehicle. In the event of any alleged breach of any warranty or any legal action brought by the customer based on alleged negligence or other conduct by CFMOTO POWERSPORTS Inc., or its related parties, the customer's sole and exclusive remedy will be repair

WARRANTY INFORMATION

or replacement of defective components as stated above, unless otherwise provided by law. Some states do not allow limitations on how long an implied warranty lasts, so the above limitations may not apply if they are deemed inconsistent with the controlling state law.

U.S.A. EPA and CARB Emissions Control Limited Warranty

This emissions limited warranty is in addition to the CFMOTO Powersports, Inc. standard limited warranty for your vehicle. CFMOTO Powersports, Inc. warrants that at the time it is first purchased, this emissions-certified vehicle is designed, built and equipped so it conforms to applicable U.S. Environmental Protection Agency (EPA) and the California Air Resource Board (CARB) emission regulations. CFMOTO Powersports, Inc. also warrants that the vehicle is free from defects in materials and workmanship that would cause it to fail to meet these regulations.

The warranty period for this emissions-certified vehicle starts on the date the vehicle is first purchased and continues for a period of 500 hours of engine operation, 5000 kilometers (3,100 miles) of vehicle travel, or 30 calendar months from the date of purchase, whichever comes first. This emissions limited warranty covers components whose failure increases the vehicle's regulated emissions, and it covers components of systems whose only purpose is to control emissions. Repairing or replacing other components not covered by this warranty is the responsibility of the vehicle owner. This emissions limited warranty does not cover components whose failure does not increase the vehicle's regulated emissions.

WARRANTY INFORMATION

For exhaust emissions, emission-related components include any engine parts related to the following systems:

- Air-induction system (excludes filters) • Ignition system (excludes spark plugs)
- Fuel system (excludes filters) • Exhaust gas recirculation systems

The following parts are also considered emission-related components for exhaust emissions:

- After treatment devices • Sensors
- Crankcase ventilation valves • Electronic control units

The following parts are considered emission-related components for evaporative emissions:

- Fuel Tank • Vacuum Control Diaphragms*
- Fuel Cap • Control Cables*
- Fuel Line • Control Linkages*
- Fuel Line Fittings • Purge Valves
- Clamps* • Vapor Hoses
- Pressure Relief Valves* • Liquid/Vapor Separator
- Control Valves* • Carbon Canister
- Control Solenoids* • Canister Mounting Brackets

WARRANTY INFORMATION

- Electronic Controls*
- Carburetor Purge Port Connector

* As related to the evaporative emission control system.

The exclusive remedy for breach of this limited warranty shall be, at the exclusive option of CFMOTO Powersports, Inc., repair or replacement of any defective materials, components or products.

THE REMEDIES SET FORTH IN THIS LIMITED WARRANTY ARE THE ONLY REMEDIES AVAILABLE TO ANY PERSON FOR BREACH OF THIS WARRANTY. CFMOTO POWERSPORTS, INC. SHALL HAVE NO LIABILITY TO ANY PERSON FOR INCIDENTAL, CONSEQUENTIAL OR SPECIAL DAMAGES OF ANY DESCRIPTION, WHETHER ARISING OUT OF EXPRESS OR IMPLIED WARRANTY OR ANY OTHER CONTRACT, NEGLIGENCE OR OTHER TORT OR OTHERWISE. THIS EXCLUSION OF CONSEQUENTIAL, INCIDENTAL, AND SPECIAL DAMAGES IS INDEPENDENT FROM AND SHALL SURVIVE ANY FINDING THAT THE EXCLUSIVE REMEDY FAILED OF ITS ESSENTIAL PURPOSE.

WARRANTY INFORMATION

ALL IMPLIED WARRANTIES (INCLUDING BUT NOT LIMITED TO ANY IMPLIED WARRANTIES OF MERCHANTABILITY AND FITNESS FOR A PARTICULAR PURPOSE) ARE LIMITED IN DURATION TO THE WARRANTY PERIOD DESCRIBED HEREIN. CFMOTO POWERSPORTS, INC. DISCLAIMS ALL EXPRESS WARRANTIES NOT STATED IN THIS WARRANTY.

Some states do not allow limitations on how long an implied warranty lasts, so the above limitation may not apply if it is inconsistent with the controlling state law. This limited warranty excludes failures not caused by a defect in material or workmanship. This limited warranty does not cover damage due to accidents, abuse or improper handling, maintenance or use. This limited warranty also does not cover any engine that has been structurally altered, or when the vehicle has been used in racing competition. This limited warranty also does not cover physical damage, corrosion, or defects caused by fire, explosions or other similar causes beyond the control of CFMOTO Powersports, Inc. Owners are responsible for performing the scheduled maintenance identified in the owner's manual. CFMOTO Powersports, Inc. may deny warranty claims for failures that have been caused by the owner's or operator's improper maintenance or use, by accidents for which CFMOTO Powersports, Inc. has no responsibility, or by acts of God. Any qualified repair shop or person may maintain, replace, or repair the emission control devices or systems on your vehicle. CFMOTO Powersports, Inc. recommends that you contact an authorized CFMOTO Powersports, Inc. dealer to perform any service that may be necessary for your vehicle. CFMOTO Powersports, Inc. also recommends that you use only genuine CFMOTO Powersports, Inc. parts. It is a potential violation of the Clean Air Act if a part supplied by an aftermarket parts manufacturer reduces the effectiveness of the vehicle's emission controls. Tampering with emission controls is prohibited by federal law. If you have any questions regarding your warranty rights and responsibilities, please contact CFMOTO Powersports, Inc. at 888-823-6686.

WARRANTY INFORMATION

Noise Control System and Tampering

Warranty time period: 1,865 miles (3000 km)

Federal law prohibits the following acts or causing thereof:

- (1) The removal or rendering inoperative by any person other than for purposes of maintenance, repair, or replacement, of any device or element of design incorporated into any new vehicle for the purpose of noise control prior to its sale or delivery to the ultimate purchaser or while it is in use or;
- (2) The use of the vehicle after such device or element of design has been removed or rendered inoperative by any person.

AMONG THOSE ACTS PRESUMED TO CONSTITUTE TAMPERING ARE THE ACTS LISTED BELOW:

These acts include tampering with the following systems; i.e., modification, removal, etc.

Exhaust system

- Muffler
- Exhaust
- Silencer

Intake system

- Air cleaner case
- Air cleaner element
- Intake duct



IMPORT BY: CFMOTO POWERSPORTS, INC.

3555 Holly Lane N. Suite #30, Plymouth, MN 55447, USA

Toll Free: (888)8-CFMOTO(823-6686)

Tel:(1)763 398 2690 Fax:(1)763 398 2695

Website: www.cfmotousa.com