

UFORCE 600



CF600UU
CF600UZ

OWNER'S
MANUAL

READ THIS MANUAL CAREFULLY

It contains important safety information

**This ROV should not be ridden by anyone under 16
years of age. Passenger under 12 are prohibited.**

TABLE OF CONTENTS

Foreword	5
Welcome	5
EVAP System (Evaporative Emission Control System)	6
Catalytic Converter.....	6
Signal Words.....	7
Introduction.....	10
Vehicle Identification Numbers and Key Information.....	11
Specifications	12
Operator Safety	18
General Safety Precautions	18
Owner Responsibilities.....	22
Safety Labels, Locations and Warnings.....	27
Potential Hazard Warnings.....	34
Controls and Features	52
Occupant Protection.....	52
Primary Controls	54
Secondary Controls.....	58
Vehicle Features	65
CVT System	71

How to Avoid CVT Drive Belt and Clutch Failures.....	72
Dashboard Indicators and Warnings	75
Operating Your Vehicle	84
Break-In Period	84
Pre-Ride Inspection.....	86
Throttle	86
Foot Brake.....	87
Starting the Engine.....	87
Shifting the Transmission	88
Safe Operation - Driving Safely	92
Responsibilities of the Operator	92
Practice Exercises.....	95
Operating Your Vehicle.....	98
Hauling and Towing Loads	103
Winch Operation	108
Maintenance	118
Severe Use Definition	118
Pre-Ride Maintenance Checklist.....	120
Break-In Maintenance Checklist	122
Periodic Maintenance Schedule.....	124

Maintenance Procedures	131
Cleaning and Storage	167
Transporting the Vehicle	171
Vehicle Issue Diagnosis	172
Engine Does not Turn Over	172
Engine Pings or Knocks	172
Engine Stops or Loses Power	173
Engine Turns Over, Fails to Start	174
Engine Backfires	175
Engine turns over, Fails to start.....	175
EFI Malfunction Indicator Light	177
EPS Malfunction Indicator Light	178
Electronic Power Steering (EPS) Fault Diagnosis and Solution	179
CFMOTO Limited Warranty	180
CFMOTO Warranty Terms & Conditions	180
U.S.A. EPA and CARB Emissions Control Limited Warranty	187
Noise Control System and Tampering	190
Change of Ownership	191

FOREWORD

Foreword

Welcome

Thank you for purchasing a CFMOTO vehicle, and welcome to our world-wide family of CFMOTO enthusiasts. Be sure to visit us online at www.cfmoto.com for the latest news, new product introductions, upcoming events, and more.

CFMOTO is an international company that specializes in the development, manufacture, and marketing of all-terrain vehicles, utility vehicles, large displacement motorcycles, and their core components. Founded in 1989, CFMOTO is devoted to the development of independent brand cultivation and R&D innovation. CFMOTO products are currently distributed through more than 2000 companions worldwide in more than 100 countries and regions. CFMOTO is edging into the advanced ranks in the world of powersports, and aims to supply superior products to dealers and fans globally.

For safe and enjoyable operation of your vehicle, be sure to follow the instructions and recommendations in this owner's manual. Your manual contains instructions for minor maintenance. Information about major repairs is outlined in the CFMOTO Service Manual.

Your CFMOTO dealer knows your vehicle best and is interested in your total satisfaction. Be sure to return to your dealership for all of your service needs during, and after, the warranty period.

Due to constant improvements in the design, quality, or configuration of production components, some minor discrepancies may result between the actual vehicle and the information presented in this publication. CFMOTO reserves the right to change product features, specifications and components without notice or incurring obligation to the purchaser. Depictions and/or procedures within are intended for reference use only. The most current version of this manual may be available on the CFMOTO consumer website of the market you reside in.

FOREWORD

WARNING

The engine exhaust from this product contains chemicals known to the State of California to cause cancer, birth defects or other reproductive harm.

EVAP System (Evaporative Emission Control System)

(If equipped)

When required by environmental emissions regulations, this vehicle is manufactured with a fuel evaporation system (EVAP) to prevent fuel vapors entering the atmosphere from the fuel tank and fuel system.

During routine maintenance, visually inspect all hose connections for leaks or blockage. Ensure the hoses are not clogged or kinked, which could damage the fuel pump or distort the fuel tank. No other maintenance is necessary.

Contact your dealer if repair is required. Do not modify the EVAP system. Modifying any part of this system will violate environmental emissions regulations.

Catalytic Converter

CAUTION: Please pay attention to the following to protect your catalytic converter:

Use only unleaded gasoline. Even gasoline that contains a little lead could damage the reactive metals contained in the catalytic converter and disable it.

Never add rust preventive oil or engine oil into the muffler. Doing so could damage the catalytic converter.

NOTE

Some features described within this manual may not apply to models sold in North America.

All descriptions and directions given are from the operator's perspective when properly seated.

FOREWORD

Signal Words

A signal word calls attention to a safety message or messages, a property damage message or messages, and designates a degree or level of hazard seriousness. The standard signal words in this manual are WARNING, CAUTION and NOTE or NOTICE.

The following signal words and symbols appear throughout this manual and on your vehicle. Your safety is involved when these words and symbols are used. Become familiar with their meanings before reading the manual:

WARNING

This safety alert and icon indicates a potential hazard that may result in serious injury or death.

CAUTION

This safety alert and icon indicates a potential hazard that may result in minor or moderate personal injury and/or damage to the vehicle.

CAUTION

This safety alert without an icon indicates a situation that may result in damage to the vehicle.

NOTE or NOTICE

A note or notice will alert you to important information or instructions.

FOREWORD



NEVER:

- Operate without proper training or instruction.
- Operate on public roads. A collision can occur with another vehicle.
- Operate on paved roads. Pavement may seriously affect handling and control.
- Operate at speeds too fast for your skill, conditions, or the terrain.
- Use ALCOHOL or DRUGS before or while driving this vehicle.

ALWAYS:

- Avoid paved surfaces, which may adversely affect the handling and control.
- Use proper driving techniques to avoid vehicle overturn on hills, rough terrain, and when turning.
- Wear eye protection, helmet and protective clothing.

FOREWORD

READ THE OWNER'S MANUAL FOLLOW ALL INSTRUCTIONS AND WARNINGS

WARNING

Read, understand, and follow all of the instructions and safety precautions in this manual and on all product labels. Failure to follow the safety precautions could result in serious injury or death.

WARNING

The engine exhaust gas from this product contains CO, which is deadly gas and could cause headaches, giddiness, loss of consciousness, even death. Always avoid starting the vehicle in areas with poor ventilation.

INTRODUCTION

Introduction

Thank you for purchasing a CFMOTO vehicle, and welcome to our world-wide family of CFMOTO enthusiasts.

For safe and enjoyable operation of your vehicle, be sure to follow the instructions and recommendations in this owner's manual. Information about major repairs are outlined in the CFMOTO Service Manual, and should only be performed by a CFMOTO service dealer and technician. Be sure to return to your dealership for all of your service needs during, and after, the warranty period.

If you have questions or concerns about your vehicle

All questions or concerns related to your vehicle should be directed to your local CFMOTO dealer first. Your dealer knows your vehicle best and is interested in your total satisfaction. In the event your local dealer is unable to resolve a product issue or concern, you can reach a CFMOTO customer service representative depending on the market you reside in:

For USA: Please contact CFMOTO POWERSPORTS, INC. TEL: 763-398-2690, by e-mail: info@cfmotousa.com, or online: <https://cfmotousa.com/customer-care/customer-care-contact>. Please note that customer service does not have authority to approve or deny warranty, and cannot provide technical repair data, diagnosis, or instructions.

For CANADA: Please contact CANADA MOTOR IMPORT INC. TEL: 1-418-227-2077, or online: <https://www.cfmoto.ca/en/customer-care/>.

For a safety concern related to your Canadian vehicle, you may report your concern to Transport Canada Defect Investigation and Recalls Division by mail, telephone, or online using the contact information below:

Mailing address: Transport Canada - ASFAD, 330 Sparks Street, Ottawa, ON, K1A 0N5

TEL: 819-994-3328 (Ottawa-Gatineau area or international) or toll-free: 1-800-333-0510 (In Canada)

Online: <http://www.tc.gc.ca/recalls>

INTRODUCTION

Vehicle Identification Numbers and Key Information

Record your vehicle's identification numbers in the spaces provided. Remove the spare key and store in a safe place. Your key can be duplicated only by mating a key blank with one of your existing keys. If both keys are lost, the complete lock assembly must be replaced.

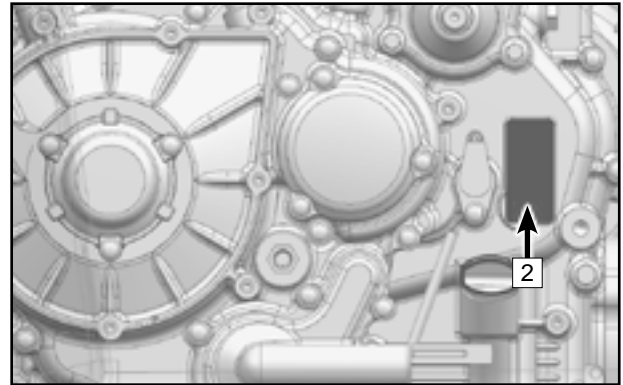
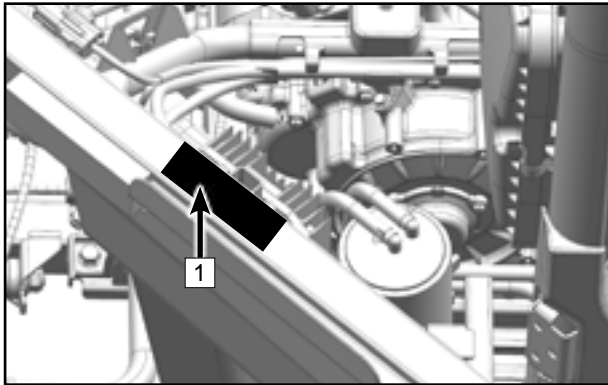

1. Vehicle Identification Number: _____

2. Engine Serial Number: _____

SPECIFICATION

Specifications

Item	UFORCE 600	
	CF600UU (EVAP)	CF600UZ (Non-EVAP)
Overall Length	111 in. (2820 mm)	
Overall Width	57.9 in. (1470 mm)	
Overall Height	76.8 in. (1950 mm)	
Wheel Base	76.8 in. (1950 mm)	
Ground Clearance	10.6 in. (270 mm)	
Minimum Turning Radius	187 in. (475 cm)	
Basic Weight	1355.8 lb. (615 kg)	
Rear Cargo Box Weight Capacity	551.2 lb. (250 kg)	
Maximum Vehicle Load Allowed	1065 lb. (483 kg)	
Recommended Towing Capacities:		
Towing Hitch Weight	150 lb. (68 kg)	
Trailer and Cargo Weight	1500 lb. (680 kg)	
Engine Model And Type	191S	
Type	Single cylinder, 4-stroke, liquid-cooled, 4 valves, SOHC	

SPECIFICATION

Item	UFORCE 600	
	CF600UU (EVAP)	CF600UZ (Non-EVAP)
Bore x Stroke	91 mmx89.2 mm	
Displacement	580cc	
Compression Ratio	10.68:1	
Starting Type	Electric start	
Lubrication Type	Pressure / Splash lubrication	
Engine Oil:	SAE 5W-40 / SAE 10W-40 / SAE 15W-40	
Type	(See page 85 for oil viscosity chart)	
Engine Oil Volume:	2.96 qt. (2.8 L)	
Capacity Change / Oil Filter	2.54 qt. (2.4 L)	
Coolant:	Commercially available – Safe for aluminum engines 3.8 qt. (3.6 L) 3.7 qt. (3.5 L) 0.32 qt (0.3 L) ~ 0.62 qt (0.59 L) 50% coolant / 50% distilled water	
Type		
Total Capacity (without reservoir capacity)		
Coolant changing capacity (without reservoir capacity)		
Reservoir capacity (lower line ~ upper line)		
Mix Ratio		

SPECIFICATION

Item	UFORCE 600	
	CF600UU (EVAP)	CF600UZ (Non-EVAP)
Front gear case Oil:		
Type	SAE 80W-90 GL-5	
Volume:		
Periodic Oil Change	8.45 oz (250 mL)	
Rear gear case Oil:		
Type	SAE 80W-90 GL-5	
Volume		
Periodic Oil Change	13.52 oz (400 mL)	
Air Filter	Paper type and foam pre-filter	
Fuel Type	89 or higher unleaded gasoline	
Fuel Tank Capacity	9.25 gal. (35 L)	
Fuel Reserve Amount At Fuel Gauge 'Flash' (Approximate)	1.32 gal. (5 L)	

SPECIFICATION

Item		UFORCE 600	
		CF600UU (EVAP)	CF600UZ (Non-EVAP)
Spark Plug Type		DCPR8E (NGK)	
Spark Plug Gap		0.031 in ~ 0.035 in (0.8 mm ~ 0.9 mm)	
Transmission	Transmission		CVT + Gearbox
	Gear Shift/Order		Manual / L—H—N—R—P
	CVT Ratio		0.67~3.02
	Gear Ratio	Low Gear	2.533
		High Gear	1.35
Reverse		2.071	
Chassis Frame	Steel tube		
Tires:			
Type	Tubeless		
Front	25x8.00 R12 60G		
Rear	25x10.00 R12 70G		
Wheel Bolt Pattern	4x110mm		

SPECIFICATION

Item	UFORCE 600	
	CF600UU (EVAP)	CF600UZ (Non-EVAP)
Tire Pressure: Front Rear	Suggest pressure: 10 PSI (70 kPa) Load > 195 kg: 11 PSI (80 kPa) Suggest pressure: 14 PSI (100 kPa) Load > 195 kg: 17 PSI (120 kPa)	
Brake System:	Front axles: Double-disc / Rear axles: Double-disc	
Foot Brake Type / Operation	Foot operated	
	Four wheel disc	
Parking Brake Type / Operation	Operated by hand Rear wheel mechanical disc brake only	
Brake Fluid Type	DOT 4	
Suspension:		
Front Suspension	Double A-arm independent	
Rear Suspension	Double A-arm independent	
Shock Absorber:		
Front Shock Absorber	Coiled spring / Oil shock	
Rear Shock Absorber	Coiled spring / Oil shock	

SPECIFICATION

Item	UFORCE 600	
	CF600UU (EVAP)	CF600UZ (Non-EVAP)
Wheel Travel: Front Wheel Travel Rear Wheel Travel	7.87 in. (200 mm) 7.87 in. (200 mm)	
Electrical System: Ignition Charging Battery	Electronic Rectified A/C 600 Watt @ 5000 rpm 12 Vdc / 30 Amp Hr	
Fuses	EPS - 40A (If equipped) Main fuse - 40A Headlight - 15A Signal control - 15A EFI - 15A Fan - 15A Back-up / spare - 15A Fuel pump - 10A HMI - 10A	
Light System: Headlight:	LED light / Halogen light (Select markets) LED / Halogen lamp(HS1 35/35W)	

OPERATOR SAFETY

Operator Safety

General Safety Precautions

WARNING

Failure to heed the warnings contained in this manual can result in serious injury or death. This vehicle is not a toy and can be hazardous to operate. This vehicle handles differently from other vehicles, such as cars. A collision or rollover can occur quickly, even during routine maneuvers like turning or driving over obstacles, if you fail to take proper precautions.

Read this owner's manual. Understand all safety warnings, precautions and operating procedures before operating this vehicle.

Age Restrictions

This vehicle is an **ADULT VEHICLE ONLY**. Operation is prohibited for anyone under the age of 16. No passengers under age 12 are allowed on CFMOTO vehicles designed to carry passengers.

Know Your Vehicle

As the operator of the vehicle, you are responsible for your personal safety, the safety of others, and the protection of the environment. Read and understand your owner's manual, which includes valuable information about all aspects of your vehicle, including safe operating procedures, environment protection and danger information, etc.

OPERATOR SAFETY

Equipment Modifications

CFMOTO is concerned with the safety of our customers and for the general public. Therefore, we strongly recommend that consumers do not install on a vehicle, any equipment that may increase the speed or power of the vehicle, or make any other modifications to the vehicle for these purposes. Any modifications to the original equipment of the vehicle create a substantial safety hazard and increase the risk of body injury. The warranty on your vehicle is terminated if any unapproved accessory equipment has been added to the vehicle, or if any modifications have been made to the vehicle that increase its speed or power.

NOTE:

The addition of certain accessory equipment which may change the handling and performance characteristics of the vehicle include, but are not limited to; mowers, plow blades, oversize tires, sprayers, large racks, lift kits and trailers. Use only approved accessories, and familiarize yourself with their function and effect on the vehicle.

Avoid Carbon Monoxide Poisoning

All engine exhaust contains carbon monoxide, a deadly gas. Breathing carbon monoxide can cause headaches, dizziness, drowsiness, nausea, confusion and eventually death.

Carbon monoxide is a colorless, odorless, tasteless gas that may be present even if you do not see or smell any engine exhaust. Deadly levels of carbon monoxide can collect rapidly, and you can quickly be overcome and unable to save yourself. Also, deadly levels of carbon monoxide can linger for hours or days in enclosed or poorly ventilated areas.

To prevent serious injury or death from carbon monoxide:

- Never run the vehicle in poorly ventilated or partially enclosed areas.
- Never run the vehicle outdoor where engine exhaust can be drawn into a building through openings such as windows and doors.

OPERATOR SAFETY

Avoid Gasoline Fires and Other Hazards

Gasoline is extremely flammable and highly explosive. Fuel vapors can spread and be ignited by a spark or flame many feet away from the engine. To reduce the risk of fire or explosion, follow these instructions:

- Use only an approved gasoline container to store fuel.
- Never fill the gasoline container in the vehicle cargo box or on the vehicle. An electrical static discharge may ignite the fuel.
- Strictly adhere to proper fueling procedures.
- Never start or operate the engine if the fuel cap is not properly installed. Gasoline is poisonous and can cause injury or death.
- Never siphon gasoline by mouth.
- If you swallow gasoline, get any in your eye(s), or inhale gasoline vapor, see a doctor immediately.
- If gasoline spills on you, wash with soap and water and change your clothes.

Fuel Minimum Octane Rating and Safety Warnings

The recommended fuel for your vehicle is 89 Octane minimum, premium or mid-grade fuel (a maximum blend of 10% ethanol is allowed). Non-oxygenated (ethanol-free) fuel is recommended for best performance in all conditions.

OPERATOR SAFETY

WARNING

Gasoline is highly flammable and explosive under certain conditions.

Allow the engine and exhaust system to cool before filling the tank.

Always exercise extreme caution whenever handling gasoline.

Always refuel with the engine stopped, and outdoors or in a well ventilated area.

Never carry a plastic container with gasoline in the cargo area while riding. Static electricity between the cargo area and container could cause a spark.

Do not smoke or allow open flames or sparks in or near the area where refueling is performed, or where gasoline is stored.

Do not overfill the tank. Do not fill to the tank neck.

If gasoline spills on your skin or clothing, immediately wash it off with soap and water and change clothing. Never start the engine or let it run in an enclosed area. Engine exhaust fumes are poisonous and can cause loss of consciousness or death in a short time.

The engine exhaust from this product contains chemicals known to cause cancer, birth defects or other reproductive harm. Operate this vehicle only outdoors or in well-ventilated areas.

Avoid Burns from Hot Parts

The exhaust system and engine become hot during operation. Avoid contact during and shortly after operation to avoid burns.

OPERATOR SAFETY

Owner Responsibilities

Be Qualified and Responsible

Read this Owner's Manual and the warning decals on this vehicle carefully. Take a safety training course on open areas if available. Practice at low speeds. Higher speeds require greater experience, knowledge and suitable riding conditions. Become completely familiar with the operational controls and the general operation of the vehicle.

This vehicle is an ADULT VEHICLE ONLY. Operation is prohibited for anyone under 16 years of age. Operators must be tall enough to be properly seated back against the backrest with the seat belt fastened, to hold the steering wheel with both hands and still be able to reach the full stroke of brake and throttle pedals with the right foot, and able to firmly plant their left foot on the footrest.

Operators may be required to have a proper driver's license in accordance with local laws.

Carrying a Passenger

- Only carry one passenger. The passenger must be properly seated in the passenger seat.
- The passenger must be at least 12 years old and tall enough to always be properly seated against the backrest with the seat belt fastened, holding handhold, and feet firmly planted; right foot on the footrest and the left foot on the vehicle floor.
- Never carry a passenger who has used drugs or alcohol, or is tired or ill. These slow reaction time and impair judgment.
- Instruct the passenger to read the vehicle's safety labels.
- Never carry a passenger if you judge their ability or judgment is insufficient to concentrate on the terrain conditions and adapt accordingly. More specifically for side-by-side vehicles, the passenger must also pay constant attention to the terrain ahead and be able to brace for bumps.

OPERATOR SAFETY

Riding Carefully

- This vehicle is not a toy and can be hazardous to operate. This vehicle handles differently from other vehicles such as motorcycles or cars. A collision or rollover can occur quickly, during abrupt maneuvers such as sharp turns, acceleration or deceleration, and driving on hills or over obstacles if you fail to take proper precautions.
- Never operate at excessive speeds. Always operate at a speed that is proper for the terrain, visibility, and operating conditions, and your experience.
- Never attempt jumps, side slides, donuts, or any other stunts.
- Never attempt rapid acceleration or deceleration when performing a sharp turn. This may result in a rollover.
- Never attempt skidding or sliding. If vehicle starts to skid or slide, counter-steer in the direction of skidding or sliding. On extremely slippery surfaces, such as ice, go slowly and be very cautious in order to reduce the chance of skidding out of control.
- Always be sure there are no obstacles or people behind the vehicle when reversing. Pay attention to blind spots. When it is safe to proceed in reverse, go slowly.
- Never exceed the stated load limits for this vehicle. Cargo must be properly secured. Reduce speed, allow for greater braking distance and follow other instructions in this manual.
- Ensure that cargo is well distributed in the cargo box. Otherwise, it could change the center of gravity and may result in rollover.

OPERATOR SAFETY

Roll Over Protection System (ROPS)

- The ROPS on this vehicle meets the performance requirements of ISO 3471:2008. The ROPS can limit intrusions of outside objects and reduce your risk of injury in rollovers.
- Always follow all safe operating practices outlined in this manual to avoid vehicle rollover.
- Do not put your hands and/or feet outside of the vehicle when driving. The ROPS will not protect you from injury in all rollovers.
- Always have your authorized CFMOTO dealer thoroughly inspect the ROPS if it ever becomes damaged in any way.

Occupant Restraint System

- This vehicle is designed to carry one driver and one passenger, both wearing proper protective gear.
- The driver and passenger must latch the side doors or side nets and wear the seat belts at all times when riding.

Terrain Conditions

- Avoid sharp turns, abrupt acceleration and sudden braking when passing public roads.
- Always go slowly and be extra careful when operating on unfamiliar terrain. Always be alert to changing terrain conditions when operating this vehicle. Take the time to learn how the vehicle performs in different environments.
- Never operate on excessively rough, slippery or loose terrain until you have learned and practiced the skills necessary to control this vehicle on such terrain. Always be especially cautious on these kinds of terrain.

OPERATOR SAFETY

- Never operate this vehicle on hills too steep for the vehicle or your abilities. Practice on small inclines.
- Always follow proper procedures for climbing or going down hills. Never go over the top of any hill at high speed.
- Never attempt steep hills or side hilling when pulling a trailer.
- Always check for obstacles before operating in a new area. Always follow proper procedures when operating over obstacles or fallen trees.
- Never operate this vehicle in deep water or fast flowing water. Remember that wet brakes may have reduced stopping ability. Test your brakes after leaving water. If necessary, apply them several times while driving slowly to let friction dry out the brakes.
- Always ensure to properly park the vehicle on the flattest terrain section available. Put the shift lever in PARK, stop the engine, and remove the key before leaving the vehicle.
- Never assume that the vehicle will go everywhere safely. Sudden changes in terrain caused by holes, depressions, banks, softer or harder ground, or other irregularities may cause the vehicle to topple or become unstable. To avoid this, slow down and always observe the terrain ahead. If the vehicle begins to topple or rollover, the best advice is to immediately steer in the direction of the rollover.
- Never attempt to prevent a rollover with your arms or legs. Always keep limbs inside the ROPS cage.

OPERATOR SAFETY

Safe Riding Gear

Always wear clothing suited to the type of riding. Operating this vehicle requires wearing special protective clothing for comfort and to reduce the chance of injury:

1. A helmet is the most important piece of protective gear for safe riding. An approved helmet can prevent a severe head injury.
2. Eye protection. A pair of goggles or a helmet face shield offers the best protection for your eyes. They should be kept clean and be a shatter-proof design. Do not depend on sunglasses for proper eye protection.
3. Off-road style gloves with knuckle pads are the best for comfort and protection.
4. The best footwear is a pair of strong over-the-calf boots with heels.
5. Always wear long pants and long sleeve shirts to protect arms and legs. Riding pants and a jersey that have kneepads and shoulder pads provide the best protection.

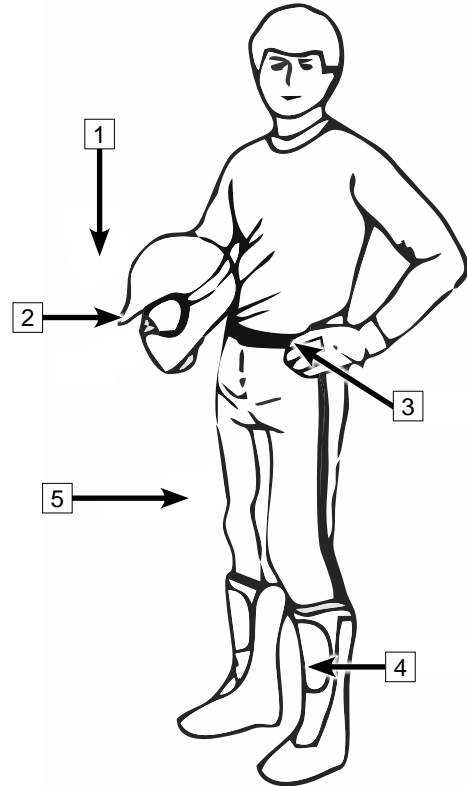

OPERATOR SAFETY

Safety Labels, Locations and Warnings

Warning labels have been placed on the vehicle for your protection. Read and follow the instructions on each decal carefully. If a decal becomes illegible or comes off, contact your dealer to purchase a replacement. Read and follow the safety warnings in this manual.

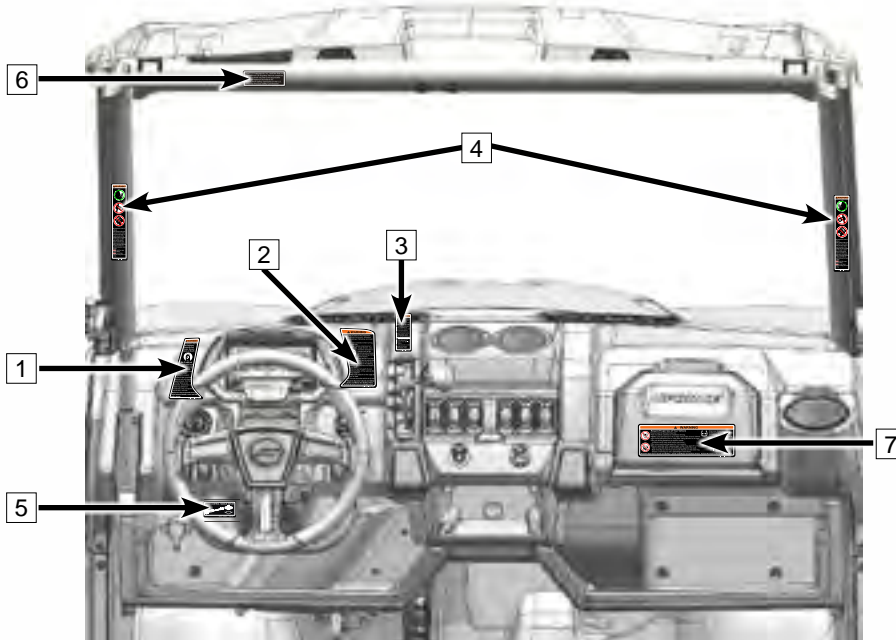

OPERATOR SAFETY

Safety Labels

1

⚠ WARNING

Improper Use of Off-Highway Vehicles Can Cause Severe Injury or Death



Be Prepared

- Fasten seat belts and make sure nets or doors are securely latched in place.
- Wear an approved helmet and protective gear.
- Each rider must be able to sit with back against seat, foot flat on the floor or on footrest, and hands on steering wheel or handholds. Stay completely inside the vehicle.

Rollovers have caused severe injuries and death, even on flat, open areas.

5AS0-190006-6000 US209

2

⚠ WARNING

Avoid loss of control and rollovers:

- Avoid abrupt maneuvers, sideways sliding, skidding or fishtailing, and never do donuts.
- Avoid hard acceleration when turning, even from a stop.
- Slow down before entering a turn.
- Plan for hills, rough terrain, ruts, and other changes in traction and terrain.
- Avoid paved surfaces.
- Avoid side hilling (riding across slopes).



Be Sure Riders Pay Attention and Plan Ahead If you think or feel the vehicle may tip or roll, reduce your risk of injury:

- Keep a firm grip on the steering wheel or handholds and brace yourself.
- Do not put any part of your body outside of the vehicle for any reason.
- NEVER attach to the cage to pull a load.
- This can cause the vehicle to tip over.

Read the Operator's Guide and Safety Labels and Watch the Safety Video. Follow All Instructions and Warnings.

5AS0-190007-6000 US209

OPERATOR SAFETY

Safety Labels

3

⚠ WARNING

**R
N
H
L**

- To avoid transmission damage, shift only when vehicle is stationary and at idle.

APPLY BRAKE TO START

- When this vehicle is not in operation or unattended, place shift in the park position.
- Stop the vehicle and apply the Brake before using the Shift Lever, the 2WD/4WD Switch and the Diff Lock Switch.

- Must use Low Gear if total payload is greater than **584 lbs. (265kg)**.
- Total payload includes weight of operator, passenger, cargo, accessories and trailer.

SAS0-190013-6000 US209

4

⚠ WARNING



Be prepared in case of rollover. If the vehicle rolls over, any part of your body (such as arms, legs, or head) outside of the cockpit can be crushed by the cage or other parts of the vehicle. Fasten seat belt and make sure net and/or door is securely latched in place to help you avoid sticking out arms or legs.

NEVER hold the cage while riding.

NEVER try to stop a rollover using your arm or leg.

SAS0-190021-6000 US209

⚠ WARNING



Be prepared in case of rollover. If the vehicle rolls over, any part of your body (such as arms, legs, or head) outside of the cockpit can be crushed by the cage or other parts of the vehicle. Fasten seat belt and make sure net and/or door is securely latched in place to help you avoid sticking out arms or legs.

NEVER hold the cage while riding.

NEVER try to stop a rollover using your arm or leg.

SAS0-190022-6000 US209

OPERATOR SAFETY

Safety Labels

5

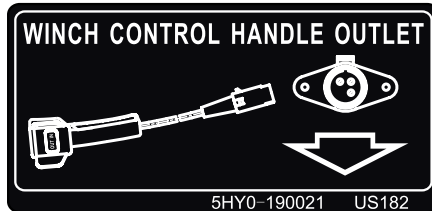

6

CFMOTO Powersports, Inc. certifies that this Recreational Off-Highway Vehicle complies with the current voluntary and applicable American National Standards for ANSI/ROHVA safety standards of the U.S. Consumer Product Safety Commission.

5HY0-190009-1 US189

7

⚠ WARNING



Require Proper Use of Your Vehicle
Do your part to prevent injuries:

- Do not allow careless or reckless driving.
- Make sure operators are 16 or older with a valid driver's license.
- Do not let people drive or ride after using alcohol or drugs.
- Do not allow operation on public roads- collisions with cars and trucks can occur.
- Do not exceed seating capacity: 2 occupants.
- Never operate with a passenger under the age of 12. All riders must be able to sit with backs against the seat.

Both feet flat on the floor and both hands on the steering wheel (if driving) or on a passenger hand hold.



Improper tire pressure or overloading can cause loss of control. Loss of control can result in severe injury or death.

- Cold tire pressure:
Front: **10 psi (70 kPa)**
Rear: **14 psi (100 kPa)**
- Maximum weight capacity:
1065 lbs. (483kg)

Read the Operator's Guide and Safety Labels and Watch the Safety Video. Follow All Instructions and Warnings.

5AS0-190008-6000 US209

OPERATOR SAFETY

Safety Labels

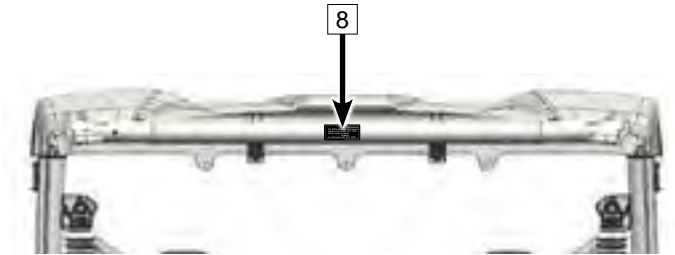

8



9



OPERATOR SAFETY

Safety Labels

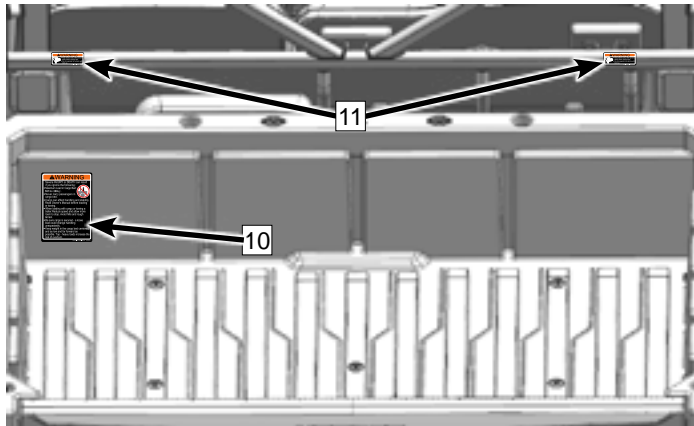

10

⚠ WARNING

Severe INJURY or DEATH can result if you ignore the following:

- Maximum Load in Cargo Bed: **551lbs.(250kg)** .
- Never carry passengers in cargo bed.
- Cargo can affect handling and stability. Read Owner's Manual before loading or towing.
- When loading with cargo or towing a trailer: Reduce speed and allow more room to stop. Avoid hills and rough terrain.
- Be sure cargo is secured - a loose load could change handling unexpectedly.
- Keep weight in the cargo bed centered, and as low and far forward as possible. Top - heavy loads increase the risk of overturn.



5AS0-190009-6000 US209

11

⚠ WARNING



- Keep hands, body, other persons away when closing bed.
- Do not operate the vehicle with bed up.

5AS0-190012-6000 US209

OPERATOR SAFETY

Safety Labels

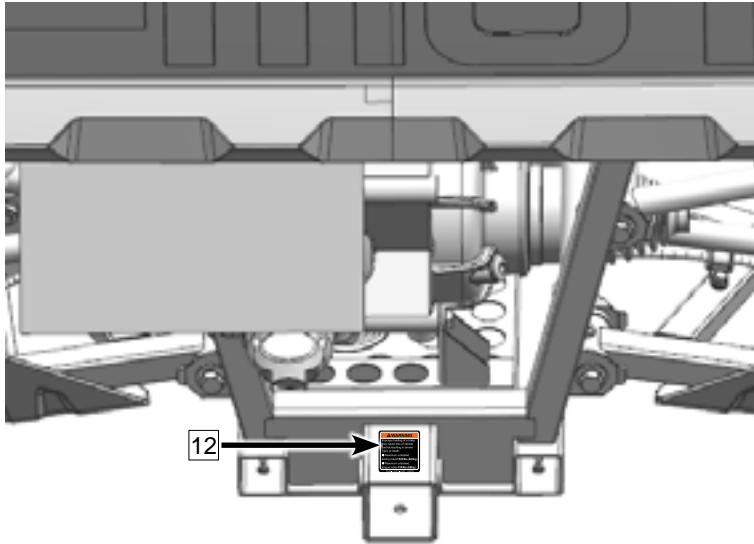

12

⚠ WARNING

Improper loading of a trailer may cause loss of vehicle control, resulting in severe injury or death.

- Maximum unbraked towing mass **1500 lbs. (680kg)**.
- Maximum unbraked tongue mass **150 lbs. (68kg)**.

5AS0-190011-6000 US209

OPERATOR SAFETY

Potential Hazard Warnings

WARNING

POTENTIAL HAZARD:

Operating this vehicle without proper instruction.

WHAT CAN HAPPEN:

The risk of an accident is greatly increased if the operator does not know how to operate the vehicle properly in different situations and on different types of terrain.

HOW TO AVOID THE HAZARD:

Beginning and inexperienced operators should complete a safety training course if offered by dealer. Operators should regularly practice the skills learned in the course and the operating techniques described in the owner's manual.

WARNING

POTENTIAL HAZARD:

Failure to follow the age recommendations for this vehicle.

WHAT CAN HAPPEN:

Severe injury and/or death could occur if a child under the minimum age recommendation operates this vehicle. Even though a child may be within the recommended age group for operating, he/she may not have the skills, abilities, or judgment needed to operate safely and could lead to accident or injury.

HOW TO AVOID THE HAZARD:

Operation is prohibited for anyone under 16 years of age.

OPERATOR SAFETY

WARNING

POTENTIAL HAZARD:

Carrying more passengers than the rated capacity.

WHAT CAN HAPPEN:

A passenger not seated in the vehicle could be ejected from the vehicle unexpectedly or make contact with moving components, both of which can result in severe injury or death.

HOW TO AVOID THE HAZARD:

Never allow carrying more than one passengers.

WARNING

POTENTIAL HAZARD:

Operation on paved surfaces such as sidewalks, trails, parking lots, or public highways and streets.

WHAT CAN HAPPEN:

All-terrain tires are designed for off-road use. Driving on paved surfaces greatly affects how a vehicle handles, which can result in loss of control and/or an accident.

HOW TO AVOID THE HAZARD:

Never drive on paved surfaces. If it is unavoidable, slow down and do not make sudden turning or braking maneuvers.

Never operate on public highways or streets if it is not allowed by law. Check local laws to determine if it is legal to do so.

OPERATOR SAFETY

⚠️ WARNING

POTENTIAL HAZARD:

Operating this vehicle without wearing approved helmet, eye protection, and protective clothing.

WHAT CAN HAPPEN:

Operating without an approved helmet increases the risk of a severe head injury or death in the event of an accident. Operating without eye protection could result in an accident and could increase the chance of a severe eye injury in the event of an accident. Operating without protective clothing could increase the chance of a severe injury.

HOW TO AVOID THE HAZARD:

Always wear an approved helmet that fits properly. Always wear eye protection (goggles or face shield), gloves, long-sleeved shirt or jacket, long pants, and over-the-calf boots.

⚠️ WARNING

POTENTIAL HAZARD:

Operating the vehicle after consuming alcohol or drugs.

WHAT CAN HAPPEN:

Consumption of alcohol and/or drugs could seriously affect operator judgment. Reaction time may be slower and operator balance and perception could be affected. Consumption of alcohol and/or drugs before or while operating a vehicle could result in an accident causing severe injury or death.

HOW TO AVOID THE HAZARD:

Never consume alcohol or drugs before or while operating the vehicle.



OPERATOR SAFETY

WARNING

POTENTIAL HAZARD:

Operating at excessive speeds.

WHAT CAN HAPPEN:

Excessive speed increases the operator's chance of losing control, which can result in an accident.

HOW TO AVOID THE HAZARD:

Always operate at a speed that's proper for the terrain, visibility and operating conditions, and your experience.

WARNING

POTENTIAL HAZARD:

Attempting slides, jumps, and other stunts.

WHAT CAN HAPPEN:

Attempting stunts increases the chance of an accident, including an overturn.

HOW TO AVOID THE HAZARD:

Never attempt slides, jumps, or other stunts.

OPERATOR SAFETY

WARNING

POTENTIAL HAZARD:

Failure to inspect the vehicle before operating. Failure to properly maintain the vehicle.

WHAT CAN HAPPEN:

Poor maintenance increases the possibility of an accident or equipment damage.

HOW TO AVOID THE HAZARD:

Always inspect your vehicle before each use to make sure it's in safe operating condition.

Always follow the inspection and maintenance procedures and schedules described in the owner's manual.

WARNING

POTENTIAL HAZARD:

Extending arms, hands, or legs outside the ROPS bars of the vehicle during operation.

WHAT CAN HAPPEN:

Severe injury can occur to arms, hands, or legs if the vehicle overturns or rolls over in an accident.

HOW TO AVOID THE HAZARD:

Always keep arms, hands, or legs inside the vehicle, hands on the steering wheel or hand grip, and keep both feet on the footrests of the vehicle during operation.

OPERATOR SAFETY

WARNING

POTENTIAL HAZARD:

Failure to use extra caution when operating on unfamiliar terrain.

WHAT CAN HAPPEN:

Unfamiliar terrain may contain hidden rocks, bumps, or holes that could cause loss of control or overturn.

HOW TO AVOID THE HAZARD:

Travel slowly and use extra caution when operating on unfamiliar terrain. Always be alert to changing terrain conditions.

WARNING

POTENTIAL HAZARD:

Turning improperly.

WHAT CAN HAPPEN:

Improper turns could cause loss of control and lead to a collision or overturn.

HOW TO AVOID THE HAZARD:

Always follow proper procedures for turning as described in the owner's manual. Practice turning at slow speeds before attempting to turn at faster speeds. Never turn at excessive speed.

OPERATOR SAFETY

WARNING

POTENTIAL HAZARD:

Failure to use extra caution when operating on excessively rough, slippery or loose terrain.

WHAT CAN HAPPEN:

Operating on excessively rough, slippery or loose terrain could cause loss of traction or loss of control, which could result in an accident or overturn.

HOW TO AVOID THE HAZARD:

Do not operate on excessively rough, slippery or loose terrain until you've practiced and learned the skills necessary to control the vehicle on such terrain. Always use extra caution on rough, slippery or loose terrain.

OPERATOR SAFETY

WARNING

POTENTIAL HAZARD:

Climbing excessively steep hills or climbing hills improperly.

WHAT CAN HAPPEN:

Improper hill climbing could cause loss of control or overturn.

HOW TO AVOID THE HAZARD:

Never operate on hills too steep for the vehicle or for your abilities. Practice on smaller hills before attempting large hills. Always check the terrain carefully before ascending any hill. Never climb hills with excessively slippery or loose surfaces. Never open the throttle suddenly while traveling uphill. The vehicle could flip over backwards. Never go over the top of any hill at high speed. An obstacle, a sharp drop, another vehicle, or person could be on the other side of the hill.

OPERATOR SAFETY

WARNING

POTENTIAL HAZARD:

Traveling down excessively steep hills.

WHAT CAN HAPPEN:

Improper downhill travel could cause loss of control or overturn.

HOW TO AVOID THE HAZARD:

Never operate on hills too steep for the vehicle or for your abilities. Practice on smaller hills before attempting large hills. Always check the terrain carefully before attempting any hill. Never descend hills with excessively slippery or loose surfaces.

NOTE:

Always check the terrain carefully before descending a hill. Never travel down a hill at high speed. Avoid traveling down a hill at an angle. Travel straight down the hill when possible.

OPERATOR SAFETY

WARNING

POTENTIAL HAZARD:

Improperly crossing hills and turning on hills.

WHAT CAN HAPPEN:

Improperly crossing or turning on hills could cause loss of control or overturn.

HOW TO AVOID THE HAZARD:

Use extra caution when turning on any hill. Avoid crossing the side of a steep hill.

WHEN CROSSING THE SIDE OF A HILL:

Always follow proper procedures as described in the owner's manual. Avoid hills with excessively slippery or loose surfaces.

OPERATOR SAFETY

WARNING

POTENTIAL HAZARD:

Stalling, rolling backwards while climbing a hill.

WHAT CAN HAPPEN:

The vehicle could overturn.

HOW TO AVOID THE HAZARD:

Maintain a steady speed when climbing a hill.

IF ALL FORWARD SPEED IS LOST:

Close the throttle. Apply the brake. When fully stopped, shift the gear selector to the park position.

IF THE VEHICLE BEGINS ROLLING:

Never apply engine power. Carefully apply the foot brake while rolling backwards. When fully stopped, keep the brake applied, shift the gear selector to the parking position, and determine the best way to safely change direction.

OPERATOR SAFETY

WARNING

POTENTIAL HAZARD:

Improperly operating over obstacles.

WHAT CAN HAPPEN:

Operating over obstacles could cause loss of control or overturn.

HOW TO AVOID THE HAZARD:

Before operating in a new area, check for obstacles. Avoid operating over large obstacles such as rocks and fallen trees when possible. If unavoidable, use extreme caution and always follow proper procedures as outlined in the owner's manual.

WARNING

POTENTIAL HAZARD:

Skidding or sliding.

WHAT CAN HAPPEN:

Skidding or sliding can cause loss of control. If the tires regain traction unexpectedly, the vehicle could overturn.

HOW TO AVOID THE HAZARD:

On slippery surfaces such as ice, travel slowly and use extra caution to reduce the chance of skidding or sliding out of control.

OPERATOR SAFETY

WARNING

POTENTIAL HAZARD:

Overloading the vehicle or carrying/towing cargo improperly.

WHAT CAN HAPPEN:

Overloading and towing can cause changes in vehicle handling, which could lead to loss of control or an accident.

HOW TO AVOID THE HAZARD:

Never exceed the stated load capacity for this vehicle.

Cargo should be properly distributed and securely attached. Reduce speed and always use low gear when carrying cargo or pulling a trailer. Allow a greater distance for braking. Always follow the instructions in the owner's manual for carrying cargo or pulling a trailer.

OPERATOR SAFETY

WARNING

POTENTIAL HAZARD:

Operation the vehicle through deep or fast-flowing water.

WHAT CAN HAPPEN:

Tires may float, causing loss of traction and loss of control, which can lead to an accident or overturn.

HOW TO AVOID THE HAZARD:

Avoid operating through deep or fast-flowing water. If it is unavoidable to enter water that exceeds the recommended maximum depth, travel slowly, balance your weight carefully, avoid sudden movements, and maintain a slow and steady forward motion. Do not make sudden turns or stops, and do not make sudden throttle changes. Wet brakes may have reduced stopping ability. Always test the brakes after leaving the water. If necessary, apply the brakes several times while driving slowly to dry out the pads.

OPERATOR SAFETY

WARNING

POTENTIAL HAZARD:

Improperly operating in reverse.

WHAT CAN HAPPEN:

The vehicle could collide with an obstacle or person, resulting in severe injury.

HOW TO AVOID THE HAZARD:

Before shifting into reverse gear, always check for obstacles or people behind the vehicle. When it's safe to proceed, back slowly.

WARNING

POTENTIAL HAZARD:

Operating this vehicle with improper tires, or with improper or uneven tire pressure.

WHAT CAN HAPPEN:

Use of improper tires, or operation of the vehicle with improper or uneven tire pressure, could cause loss of control or an accident.

HOW TO AVOID THE HAZARD:

Always use the size and type of tires specified in the owner's manual. Always maintain proper tire pressure.

OPERATOR SAFETY

WARNING

POTENTIAL HAZARD:

Operating the vehicle with improper modifications.

WHAT CAN HAPPEN:

Improper installation of accessories or modification of the vehicle may cause changes in handling which could lead to an accident.

HOW TO AVOID THE HAZARD:

Never modify the vehicle through improper installation or use of accessories. All parts and accessories added to the vehicle must be genuine parts or equivalent components designed for use on this vehicle, and they should be installed and used according to approved instructions. Consult your dealer for more information.

WARNING

POTENTIAL HAZARD:

Operating on frozen bodies of water.

WHAT CAN HAPPEN:

Severe injury or death can result if the vehicle falls through the ice.

HOW TO AVOID THE HAZARD:

Never operate the vehicle on a frozen body of water.

OPERATOR SAFETY

WARNING

Leaving the keys in the ignition can lead to unauthorized use of the vehicle, resulting in serious injury or death. Always remove the ignition key when the vehicle is not in use.

WARNING

After any overturn or accident, have an authorized dealer inspect the entire vehicle for possible damage, including (but not limited to) brakes, throttle and steering systems.

WARNING

Safe operation of this vehicle requires good judgment and physical skills. Persons with cognitive or physical disabilities who operate this vehicle have an increased risk of overturn and loss of control, which could result in severe injury or death.

WARNING

Exhaust system components are very hot during and after use of the vehicle. Hot components can cause serious burns and fire. Do not touch hot exhaust system components. Always keep combustible materials away from the exhaust system. Use caution when traveling through tall grass, especially dry grass.

CONTROLS AND FEATURES

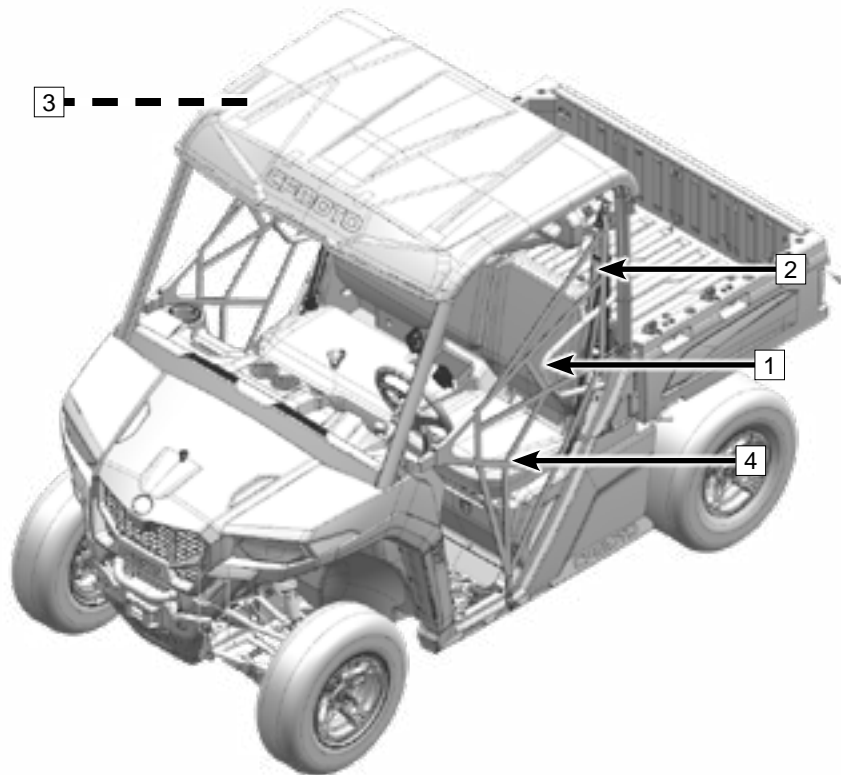

CONTROLS AND FEATURES

Controls and Features

Occupant Protection

Roll Over Protection System (ROPS) - (1)

ROPS cab frame helps to protect the occupants from injury in case of a rollover or other dangerous situation. Never put your hands and/or feet outside of the vehicle when driving.

Safety Belt - (2)

This vehicle is equipped with seat belts to help protect driver and passenger in the event of collisions, rollovers or tip over to keep occupants in the cab. Seat belt indicator light will flash if seat belt is not fastened during driving.

Safety Handrail - (3)

There is a handrail at both sides of the vehicle top bar. Holding the handrail allows the passenger to brace against the movement of the vehicle and keep the hands and body inside the cab in case of rollover.

Safety Net / Side Doors* - (4)

Side nets / side doors help to protect the driver and passenger in the cab. Always latch side nets / side doors when driving the vehicle. Make sure the side nets mounting points are fixed securely on the vehicle and buckle the latch into the lock connector (*Vehicles equipped with side nets or side doors as standard equipment according to selected market).

CONTROLS AND FEATURES

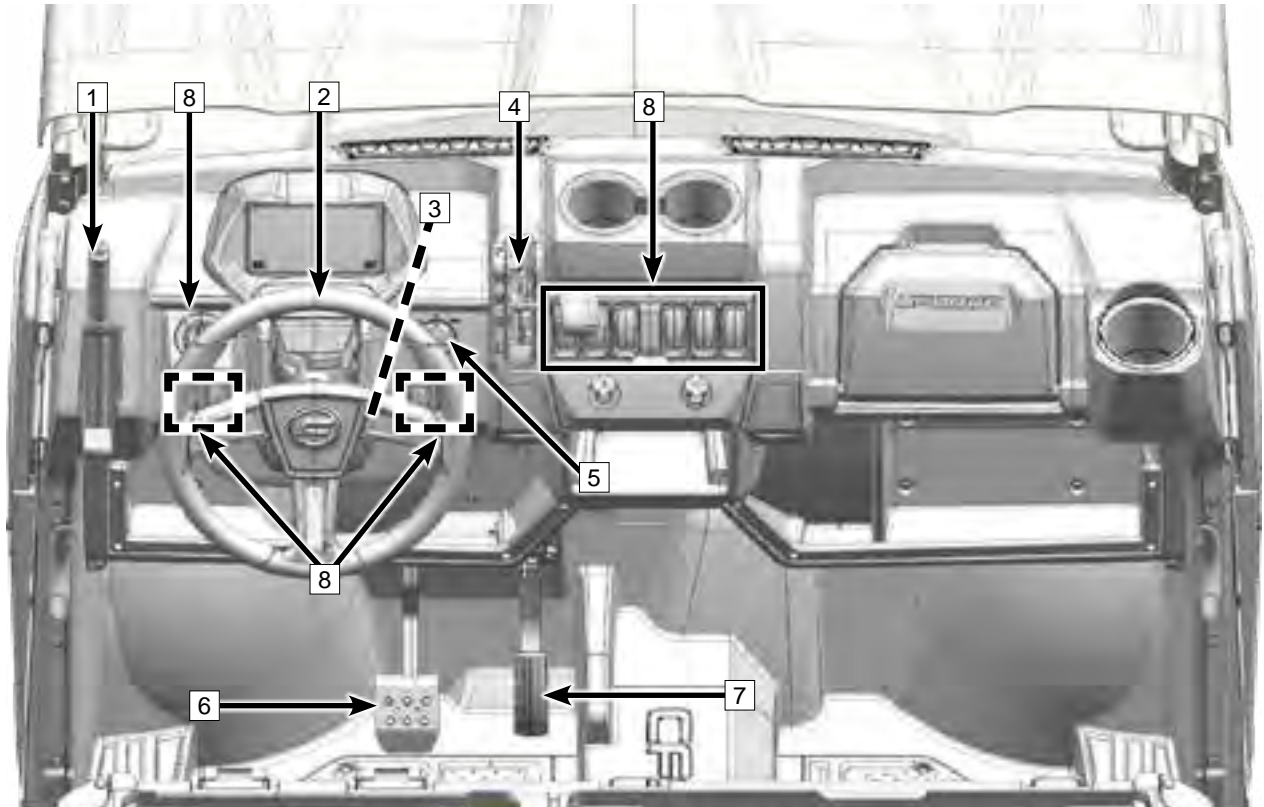

CONTROLS AND FEATURES

Primary Controls

Hand Brake - (1)

This vehicle is equipped with an auxiliary hand brake, which is located at the left of steering wheel. Pull down the lever to apply the mechanical brakes and prevent vehicle movement. If the vehicle is driven without releasing hand brake, the speed will be abnormal.

To release the hand brake, pull the handle lever slightly and depress the release button on top of the level, then push the lever to its original position.

CAUTION

Never depend on the transmission parking feature alone if the vehicle is parked on a hill. Always apply the hand brake and block the wheels on the downhill side of the vehicle to prevent movement. It is recommended to park the vehicle on level ground.

Make sure the hand brake is released before driving the vehicle. Driving without releasing hand brake will lead to wearing of brake pads, causing damage to the brake disc and result in a failure of the brake system.

Steering Wheel - (2)

The steering wheel is located in front of driver's seat. Use the steering wheel to turn the vehicle left or right and maneuver the vehicle in the desired direction.

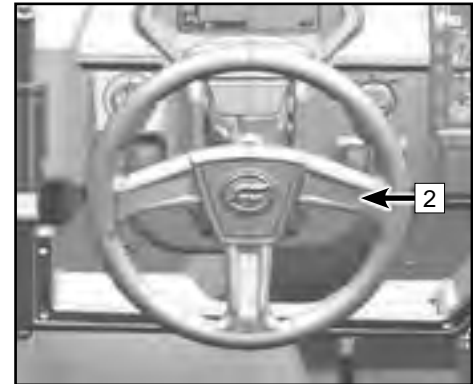
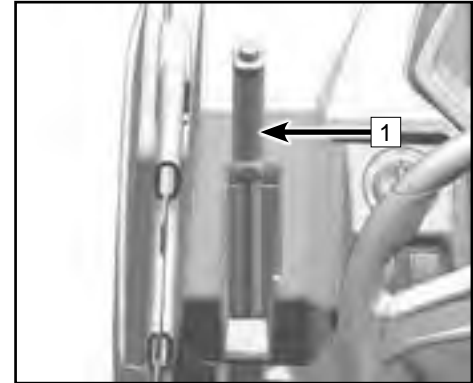

CONTROLS AND FEATURES

Tilt Lever and Steering Wheel Lock - (3)

3.1: The steering wheel can be locked. To lock, stop and park the vehicle, take the key from the ignition and insert it into the lock (3.1). With the front wheels pointed straight, turn the steering wheel left approximately 90°, then adjust the steering wheel a little until the key can turn 180° clockwise to lock it. Turn the key 180° counter-clockwise to release the steering wheel lock.

3.2: A tilt feature allows the steering wheel angle to be adjusted to fit the operator. Pull on the lever and adjust the steering wheel for comfort. Release the lever to lock the steering wheel tilt angle.

Gear Shift Lever - (4)

The gear shift lever is located at the right side of steering wheel. Use for changing the transmission gear selection. Apply brake pedal before shifting gear, to ensure personnel safety.

L – Low Gear. The low speed range of the gearbox. It allows the vehicle to move slowly with maximum torque at the wheels.

CAUTION: To avoid damage to the CVT system, always use low gear for constant slow speeds below 19mph (30 kph), pulling a trailer, carrying heavy cargo, going over obstacles, or driving up and down hills.

H – High Gear. The high speed range of the gearbox. It is for normal driving speeds over 19mph (30 kph) and allows the vehicle to reach maximum speed.

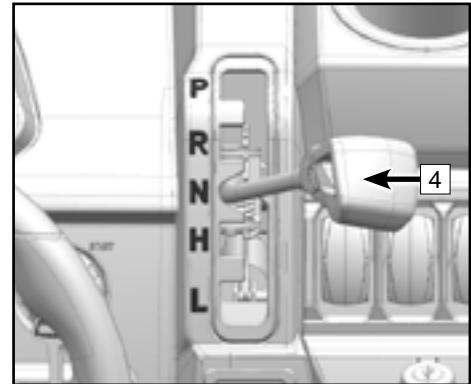
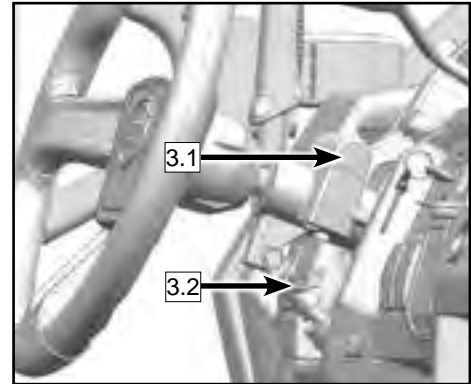

CONTROLS AND FEATURES

N – Neutral. In neutral position the engine power output is disengaged.

R – Reverse. The reverse gear position allows the vehicle to go backwards. Speed is limited to 15mph (25 kph) in reverse.

P – Park. The park position locks the gearbox to help prevent vehicle from movement.

Key Switch - (5)

Key switch is located at the right of steering wheel, use to start the vehicle power source or start engine.

OFF: Turn the key to this position, vehicle power source is off and engine does not start.

ON: Turn the key to this position, vehicle power source is on, electrical function is available.

START: Turn the key to this position, vehicle power source is on, and engine start.

Brake Pedal - (6)

The brake pedal is located at the left side of throttle pedal. Release throttle pedal and apply brake pedal to reduce speed or stop the vehicle.

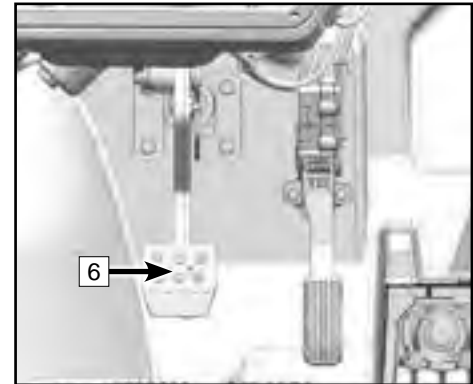
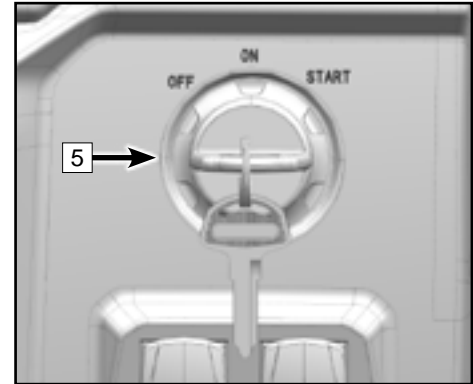

CONTROLS AND FEATURES

Electronic Throttle Pedal - (7)

The Electronic throttle pedal is located to the right of the brake pedal. The throttle pedal controls engine rpm and vehicle speed. To control vehicle speed, press on the throttle pedal with your right foot. Always check the pedal function before driving.

The electronic throttle and electronic throttle body system has the following functions:

1. Starting protection function: The vehicle can start directly on N and P gear, and requires the foot brake applied to start when the gearbox is in L or H gear.
2. Reverse speed limit function: The vehicle speed is limited to 15 mph (25kph) while it is in reverse gear.
3. 4WD-LOCK limit function: In 4WD-LOCK mode, the vehicle speed is limited to 22 mph (35 kph). Pressing the override button while in 4WD-LOCK mode removes the speed limitation.
4. Idling function: When the vehicle is in N gear, engine RPM is limited to 5000rpm.
5. Brake priority function: When the driver applies both brake pedal and throttle pedal at the same time, the electronic throttle body will return to idle automatically.
6. Limp home function: When a fault of the electronic throttle body or electronic throttle pedal is detected, the system will enter into torque limitation or limp home mode. If a fault occurs in the electronic throttle body, the engine will enter into torque limitation and RPM returns back to be idle state. If a fault occurs in the electronic throttle pedal, the vehicle will enter into limp home mode, and the top RPM will be less than 5000rpm.

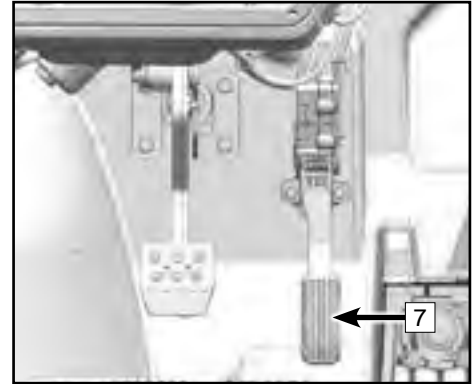



CONTROLS AND FEATURES

Secondary Controls

Switch - (8)

2WD / 4WD Switch

This vehicle is equipped with an on-command “2WD”/“4WD” and front diff-lock “LOCK”/“4WD” switch on the dashboard. Select the appropriate drive mode according to terrain and conditions:

	2WD - When the switch is on this position, power is supplied to the rear wheels only.
	4WD - When the switch is on this position, power is supplied to both front and rear wheels.
	4WD-LOCK - When the switch is on this position, power is supplied to the rear and front wheels and the front differential is locked. Unlike 4WD mode, all the wheels turn at the same speed. Speed is limited to 22 mph (35 kph). unless override is used.

WARNING

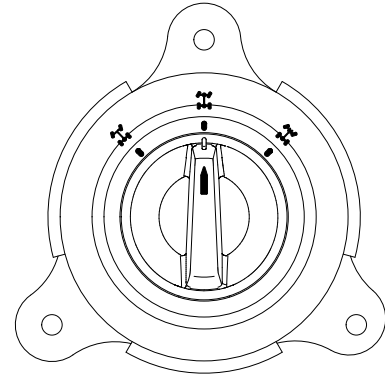

The vehicle must be stopped to engage or disengage 2WD/4WD and 4WD-LOCK. Mechanical damage may occur if the switch is engaged or disengaged while driving.



CONTROLS AND FEATURES

Main Light Switch

The main light switch consists of 3 positions. Turn the switch to select the following functions:

	When the switch is on this position, head light, position light, tail light and instrument light are 'on'.
	When the switch is on this position, position light / tail light will be 'on' and head light will be 'off'.
	When the switch is on this position, all lights are turned off.

Note:

Ignition key must be turned to 'ON' position before operating head lights.

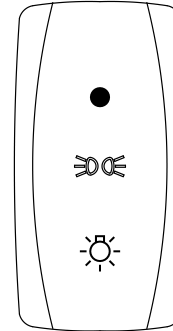

CAUTION

Do not use the headlights with the engine turned off for more than 15 minutes. The battery may discharge to a point that the starter motor will not operate properly. If this should happen, remove the battery and recharge it.



CONTROLS AND FEATURES

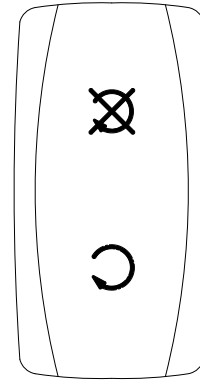

Stop Switch

	When the switch is on this position, ECU, fuel injector, ignition coil, fuel pump and starting system will stop working.
	When the switch is on this position, ECU, fuel injector, ignition coil, fuel pump and starting system will function.



Dimmer Switch

Dimmer switch consists of two positions, apply the related switch according to following function selection:

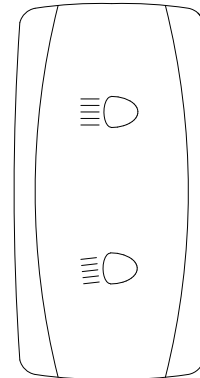

	When the switch is on this position, high beam works.
	When the switch is on this position, low beam works.



CONTROLS AND FEATURES

Horn Switch

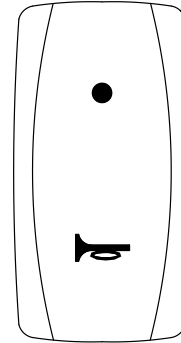

(If equipped-available only in select countries)

	Press this switch to sound the horn.
	When the switch rebounds back to this position, the horn will not sound.



Hazard Switch

(If equipped-available only in select countries)

	When the switch is on this position, front and rear turning light will flash. The hazard switch indicator light in the dashboard will be on.
	When the switch is on this position, front and rear turning light will stop flashing. The hazard switch indicator light in the dashboard will be off.

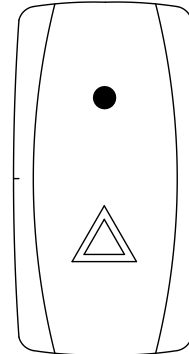

CONTROLS AND FEATURES



Override Switch

The engine is normally speed limited when operating in 4WD LOCK. If conditions require more engine power:

Release the throttle, then press and hold the override button. The override indicator light will be 'on'.

Continue to press the button, then reapply the throttle. The engine will have full power.

Release the button to restore the speed limiting function.

	When the button is on this position, speed limitation is canceled.
	When the button is on this position, the vehicle is normally speed limited.

NOTE: Override button is not active in 2WD or 4WD mode.

WARNING

Do not press override button when vehicle is in speed limiting mode and the throttle is open. Pressing the override button while the throttle is open may cause sudden acceleration, resulting in a loss of control, severe injury, or death. Always release the throttle before pressing the override button.

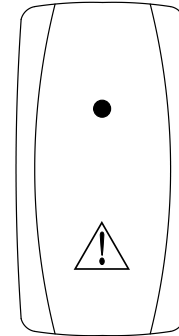

CONTROLS AND FEATURES

Mode Switch:

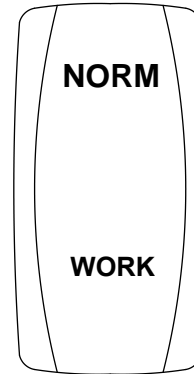

NORMAL	When the switch is on this position, the vehicle is in 'NORMAL' mode. The dashboard display will also shift to 'NORMAL' mode. The vehicle will have a less aggressive throttle response for smooth starts and is intended for flat trails, hard pack ground, etc. Use for light-duty riding. NOTE: Do not use this mode for driving situations that place high load on the CVT belt. Damage may occur.
WORK	When the switch is on this position, the vehicle is in 'WORK' mode. The dashboard display will also shift to 'WORK' mode. The vehicle will have a faster throttle response. NOTE: Use this mode for work loads, complex terrain or trails, and other driving situations that can place a high load on the CVT belt.



Turning Light Switch

(If equipped-available only in select countries)

Turning light switch consists of 3 positions, choose the related position according to the function icons:

	When the switch is on this position, left turning light flashes.
	When the switch is on this position, right turning light flashes.
•	When the switch is on this position, turning light is off.

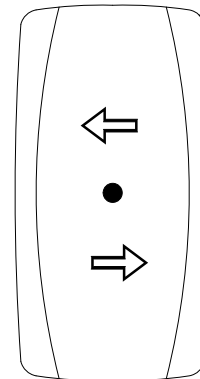

CONTROLS AND FEATURES

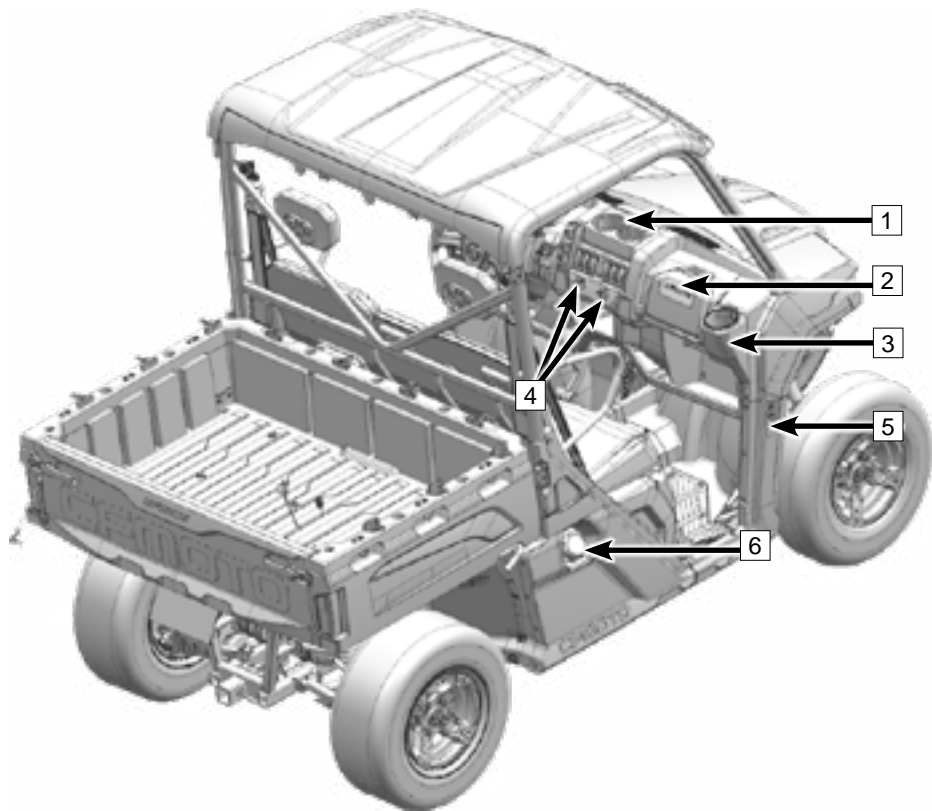

CONTROLS AND FEATURES

Vehicle Features

Cup Holder - (1)

For holding beverages.

Glove Box - (2)

The glove box is located in the front of passenger seat. A wired winch controller is located in the front glove box.

Cup Holder - (3)

In front of the passenger seat. For holding beverages.

Accessory Power Ports- (4)

Auxiliary 12Vdc power and USB outlets are provided for operating accessories such as hand-held spot lights and charging electronic devices. Please consult with your dealer on the use of powered accessories with your vehicle.

LH & RH Front Hood Clasps- (5)

Loosen the LH & RH clasps of front hood, then lift forward to gain access to electrical parts, coolant system and braking system for inspection or maintenance.

Fuel Cap - (6)

The fuel cap is located at the side of passenger seat, near the seat. Before filling with fuel, grip and turn the cap counter-clockwise to remove it. Reinstall the fuel cap after filling fuel. Fuel tank volume is 9.24 gallons (35L).

CONTROLS AND FEATURES

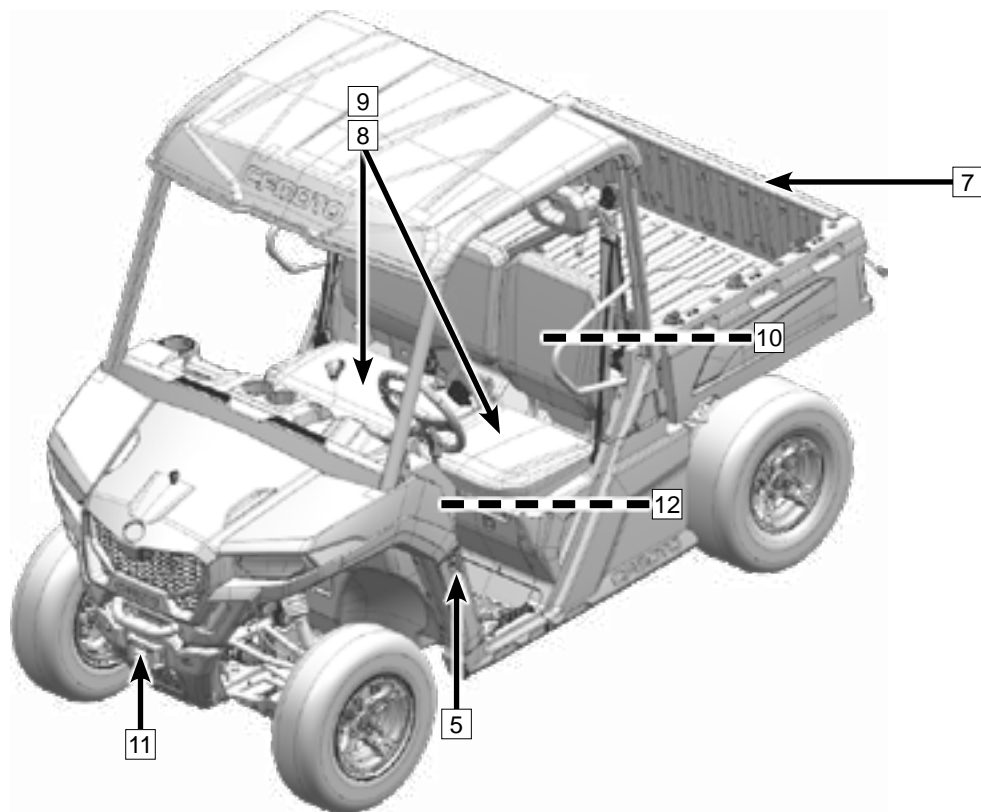

CONTROLS AND FEATURES

Cargo Box and Tilt Feature - (7)

Refer to the safety decals on the cargo box for load information. The cargo box has a release handle on each side that can be used to tilt the box (maximum angle is less than 45°) for maintenance or to dump material.

Seat - (8)

The driver's seat offers fore and aft adjustment. To adjust the seat, turn the lever to unlock it. Release the lever to lock the seat into the desired position. Two storage boxes are located under the driver and passenger seat for storing tools and other items.

Removal of the driver seat allows access to the ECU and EFI diagnostic connector located in the seat back area.

Removal: Pull up the rear part of seat **1** to release the grommet pins, then pull out backward to remove the seat base tabs from the slots.

Installation: Insert seat base tabs into the slots, then align the grommet pin and press the seat to install.

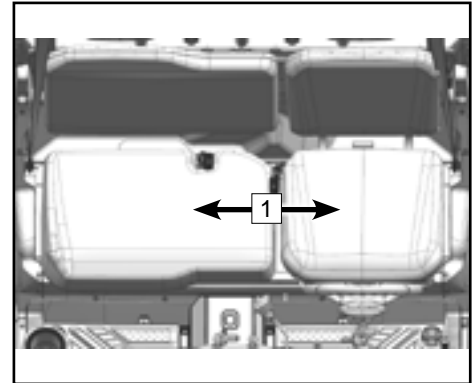

CONTROLS AND FEATURES

Seat Storage - (9)

This vehicle is equipped with storage boxes under the driver and passenger seats to store items and tools such as the funnel **2**, fill hose and tool kit **1**. The storage box under the driver seat is waterproof.

Removal of the storage boxes allow access to parts of the engine area for inspection and maintenance.

Removal: Remove the seat bases. Take out the passenger side storage box **3** first, then take out driver side storage box **4**.

Installation: Install the driver side storage box first, then install the passenger side storage box.

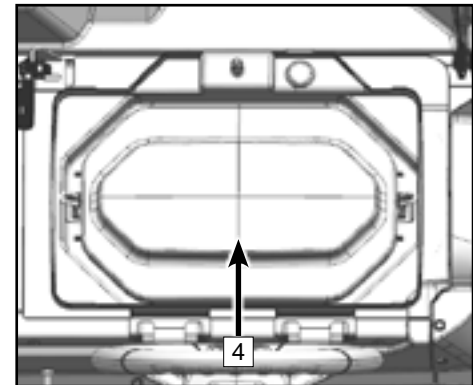
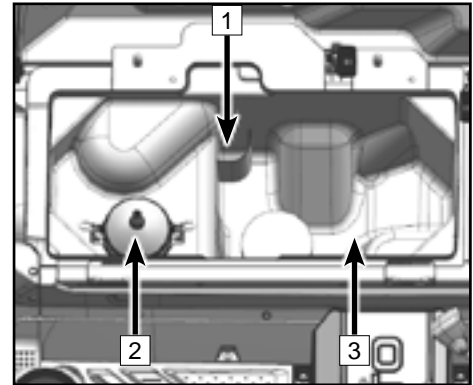

CONTROLS AND FEATURES

ECU and Fault Diagnosis Connector - (10)

ECU **2** and fault diagnosis connector **3** are located behind the driver seat.

Removal: Grasp the lower edge of ECU cover **1**, pull out to release the grommet pin, then remove the cover.

Installation: Insert the tabs into the corresponding holes, align the grommet pin and press.

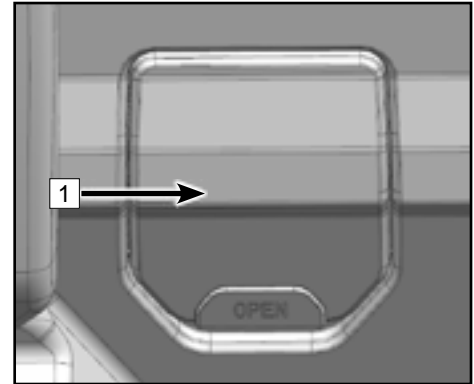

Winch - (11)

This vehicle is equipped with a 3500 lb winch, equipped with a wireless remote controller and a standard winch controller that are located inside the glove box. Only operate the winch when engine is running to retain the battery capacity. Read the winch operating section in this manual before operating the vehicle. Consult with your dealer on proper winch use.

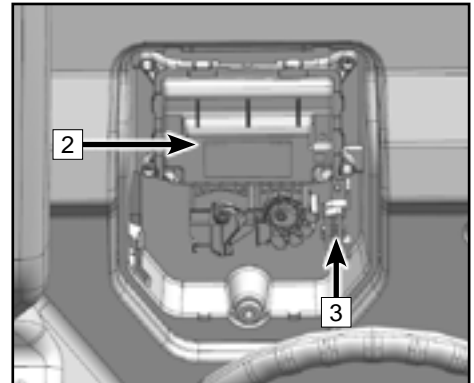

CONTROLS AND FEATURES

Wired Winch Cable Controller Power Port - (12)

This vehicle is equipped with a wired winch controller **1**, which can be designated for use if the wireless winch control is not working. The power port **2** is located on the lower left side of the steering wheel.

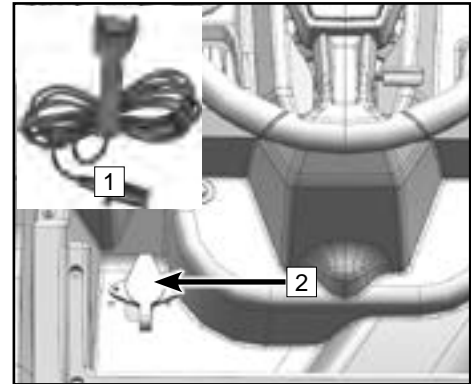

Wireless Winch Remote Control

This vehicle is equipped with a wireless remote control **3** **4** for operation of the winch system. Both the wireless remote control and wired winch controller are typically stored in the glove box on the passenger side of the dashboard.

To enable the wireless remote control: Press both control buttons at the same time. The indicator light will illuminate, and the controller can be used.

To disable the wireless remote control: Press both control buttons at the same time. The controller and indicator light will turn off.

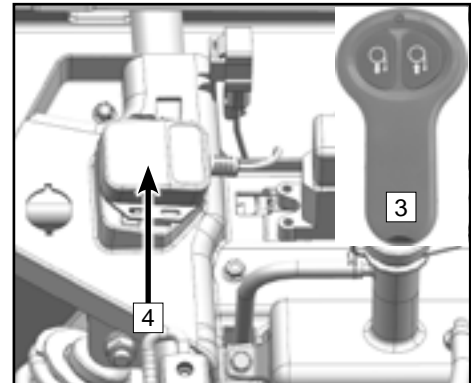

CONTROLS AND FEATURES

CVT System

This vehicle has a Continuously Variable Transmission (CVT) system that utilizes a drive belt and clutch pulleys to automatically vary transmission drive ratios, allowing infinite variability between the highest and lowest vehicle speeds with no discrete steps or shifts.

The CVT system consists of a primary clutch (1), which is an advanced form of centrifugal clutch that is mounted to the engine crankshaft (A).

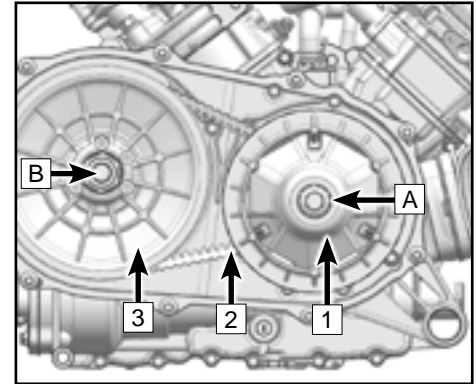

The secondary clutch (3) is mounted to the input shaft of the transmission (B) and serves two functions. As a “slave” pulley to the primary clutch, and to provide a torque sensing element that shifts drive ratios. The drive belt (2) is a heavy duty V-belt that connects the engine and transmission clutch pulleys.

A CVT housing and cover encloses the clutches and belt assembly. There are inlet and outlet cooling ducts that route air to cool the components, and they should be regularly inspected. The CVT components do not contain any user maintenance items. Contact your dealer for service.

CONTROLS AND FEATURES

How to Avoid CVT Drive Belt and Clutch Failures

CVT clutch and belt life can be dramatically extended by avoiding these common operating mistakes:

Causes CVT damage:	Solution:
Attempting to load the vehicle onto a truck bed or tall trailer in high gear.	Shift transmission to low gear during loading of the vehicle to prevent belt burning.
Starting out on a steep incline in high gear.	When starting out on steep inclines, use low gear.
Constant driving at low RPM, driving at just above clutch engagement RPM, or at low speed (approximately 3mph ~ 7mph [5km/h ~ 10km/h]) in high gear.	Low gear is highly recommended for cooler CVT operating temperatures and longer component life. Drive at a higher speed or use low gear more frequently.
Insufficient warm-up of CVT exposed to low ambient temperatures.	Warm the engine before driving, the CVT drive belt will become more flexible and prevent belt burning.
Slow throttle and easy CVT engagement.	Use the throttle with purpose and effectively for efficient CVT clutch engagement.
Towing / pushing at low RPM/low ground speed.	Use low gear only.
Utility use / plowing snow, dirt, etc.	Use low gear only.
Heavy vehicle load operating at low speed	Use low gear only.

CONTROLS AND FEATURES

Causes CVT damage:	Solution
Stuck in mud or snow.	Shift the transmission to low gear, and carefully use fast, aggressive throttle application to engage CVT. WARNING: Excessive throttle may cause loss of control and vehicle overturn.
Climbing over large objects from a stopped position.	Shift the transmission to low gear, and carefully use fast, brief, aggressive throttle application to engage the CVT. WARNING: Excessive throttle may cause loss of control and vehicle overturn.
Belt slipping from water or snow ingestion into the CVT system.	Drain the water from the CVT housing and dry the CVT if possible, or contact your dealer.
Overheating of the CVT components causes malfunction.	Contact your dealer for inspection and repair of the CVT components.

NOTE:

Low gear is the preferred transmission gear selection when:

- Constant driving speeds are lower than 19 mph (30kph)
- Driving on level road surfaces, and the vehicle is carrying/towing more than 584 lb. (265kg)
- Driving on muddy or rough road surfaces, and the vehicle is carrying/towing more than 430 lb. (195kg)

CONTROLS AND FEATURES

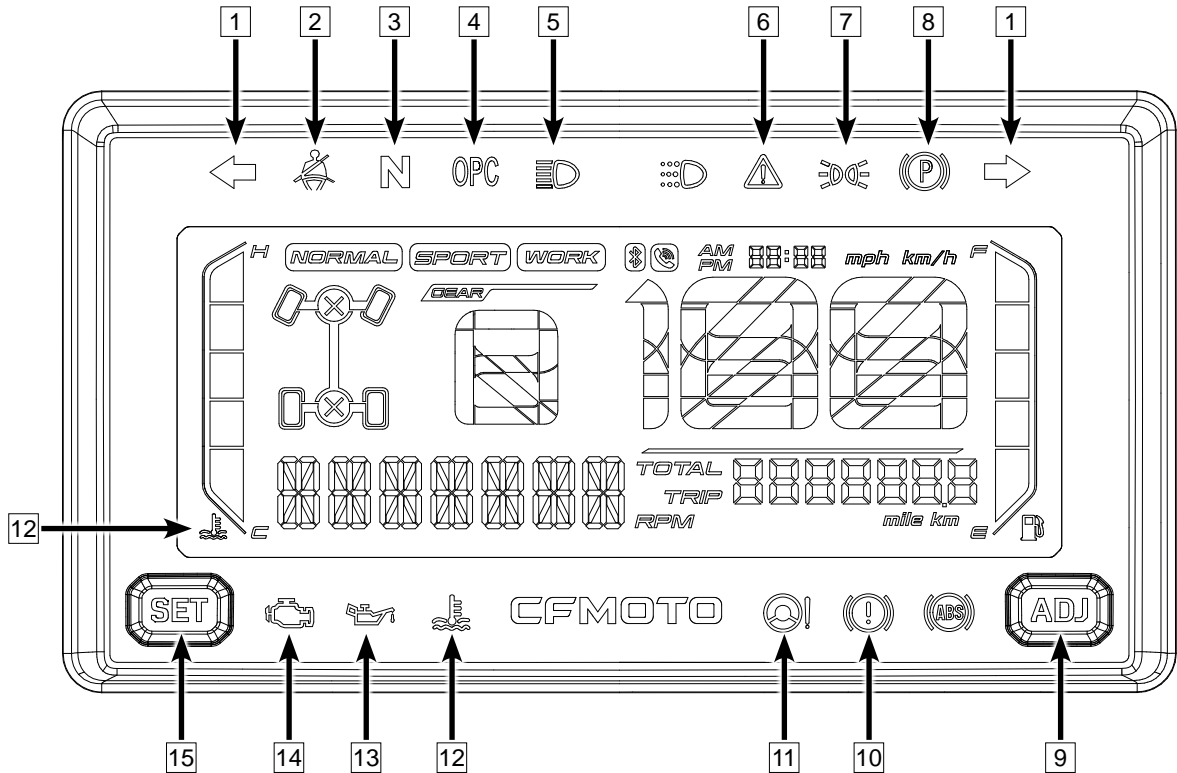

CONTROLS AND FEATURES

Dashboard Indicators and Warnings

1	Turning light	6	Override indicator	11	EPS indicator
2	Seat belt warning indicator	7	Position light	12	Coolant temp. warning indicator
3	Neutral indicator	8	Parking brake indicator	13	Oil pressure signal indicator
4	OPC indicator	9	ADJ - mode adjust button	14	EFI fault indicator
5	High beam indicator	10	Brake fault warning indicator	15	SEL - mode select button

NOTE :

Turning light is available only in select countries.

CONTROLS AND FEATURES

Indicators and Warnings

1. Turning Light (If equipped)

When switch turns to right turning light position, the right turning indicator will be on.

When switch turns to left turning light position, the left turning indicator will be on.

2. Seatbelt Warning Indicator

Seatbelt Reminder. This indicator displays when the seat belt is not fastened. The latch plate is not pushed securely into the buckle, the indicator on the dashboard will be on.

3. Neutral indicator

This indicator displays when the transmission is in neutral position.

4. OPC Indicator

When the driver leaves the seat without shifting to the parking position, this indicator will be on and alarm sounds.

5. High Beam Indicator

This indicator illuminates when the headlight switch turns to high beam position.

6. Override Indicator

When pressing the override button, the indicator is on and 4WD-LOCK speed limitation will be released in this state.

7. Position Light Indicator

This indicator illuminates when the light switch turns to position light.

CONTROLS AND FEATURES

8. Parking Brake Indicator

This indicator displays when parking brake function is activated.

9. ADJ - Mode Adjust Button

Use this key together with “SEL” key to set the information on dashboard.

10. Brake Fault Warning Indicator

This indicator displays when brake fluid level is very low. Add DOT4 brake fluid and contact your dealer. Low brake fluid level may lead to air in the brake system, causing brake fault and lead to serious accident.

11. EPS Indicator

The indicator will be on when a fault occurs in the Electronic Power Steering system. Please stop the vehicle and contact your dealer to inspect and eliminate the fault. Continuing to operate could lead to permanent EPS damage and increase the steering force.

12. Coolant Temperature Warning Indicator

Both over-low and over-high of the coolant temperature are abnormal. Idle the vehicle to warm the engine when it's too cold, and park the vehicle when it's too hot to prevent the coolant from boiling. Keep the coolant temperature in a normal range.

13. Oil Pressure Indicator

The oil pressure indicator is on when the oil pressure is very low. Please have your vehicle stopped safely at once when the indicator is on, and contact your dealer to eliminate the fault.

CONTROLS AND FEATURES

14. EFI Fault Indicator

This indicator displays when a fault occurs in the Electronic Fuel Injection system. Please stop the vehicle and contact your dealer to eliminate the fault, or it may result in serious engine damage.

15. SEL - Mode Adjust Button

Use together with “ADJ” key to adjust functions on the dashboard.

CONTROLS AND FEATURES

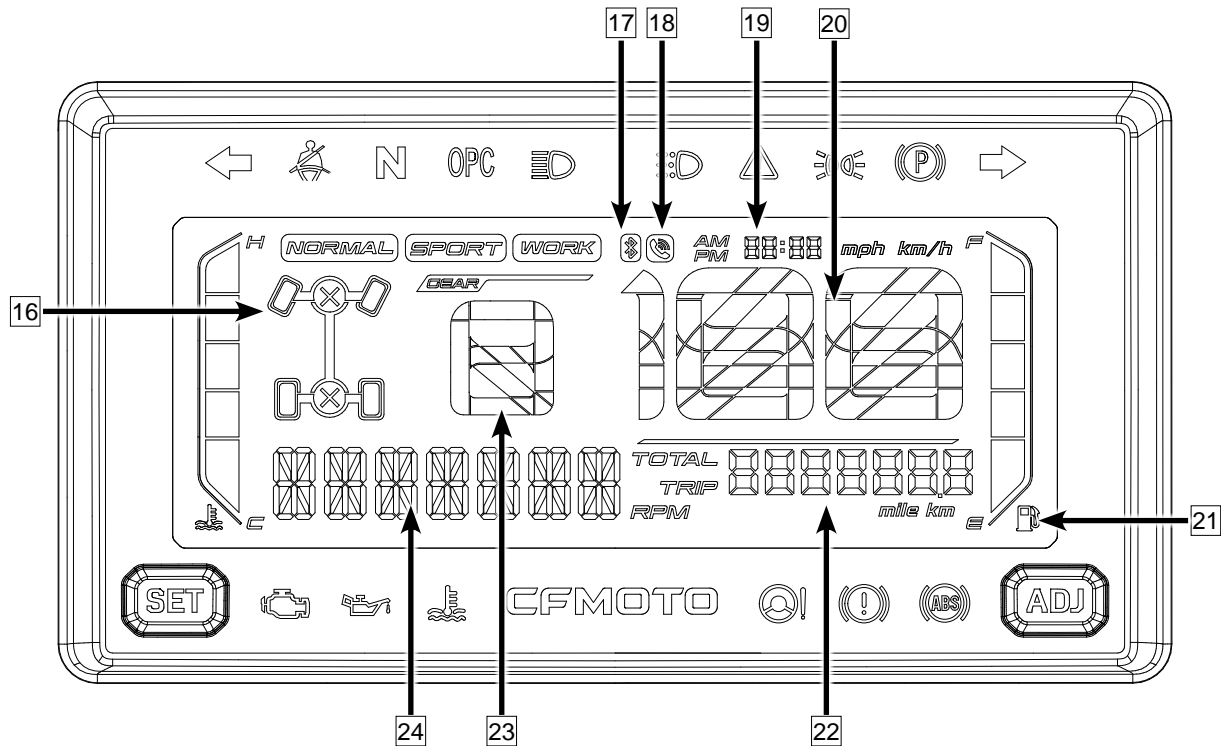

CONTROLS AND FEATURES

Dashboard Indicators and Warnings

16	Drive mode	19	Clock	22	Rider Information Center
17	Bluetooth indicator	20	Speedometer	23	Gear position indicator
18	Call indicator	21	Fuel gauge indicator	24	Engine RPM

CONTROLS AND FEATURES

16. Drive Mode

Display the current drive mode, there are three modes, 2WD, 4WD and 4WD-LOCK. If the mode is not engaged successfully, the indicator will flash.

17. Bluetooth Indicator

This vehicle is equipped with bluetooth function for connecting and disconnecting calls from a mobile phone. The bluetooth icon will not light when it is not paired and connected to a phone. It will flash during pairing and connecting, and remains on after pairing successfully and staying connected. The telephone icon will flash when there is an incoming call, it remains on while the call is connected, and it turns off when the call is disconnected.

Short-press the “SEL” button to answer the call, and short-press “ADJ” button to finish the call.

To pair, open the bluetooth function in the mobile phone, turn the vehicle main key switch to “ON”, then connect to the vehicle’s bluetooth feature using the phone.

 WARNING
--

Do not operate the vehicle while using bluetooth. Always stop the vehicle before answering a call. Distracted driving can result in an accident causing serious injury or death.

18. Call Indicator

After bluetooth pairing successfully, this indicator flashes when there is an incoming call, and it displays “CALL IN”. Short-press “SEL” to accept the call, short-press “ADJ” to finish the call.

19. Clock

Display the current time. This dashboard section can be adjusted to correct time by using the “ADJ” and “SEL” button.

CONTROLS AND FEATURES

20. Speedometer

Display the current vehicle speed. Speedometer section can be toggled to display the vehicle speed in Kilometers per hour (km/h) or Miles Per Hour (MPH) by the “ADJ” and “SEL” keys.

21. Fuel Gauge / Low Fuel Indicator

Display the fuel level in the fuel tank.

22. Rider Information Center

Indicates the total mileage the vehicle has traveled. Press “SEL” button to toggle to TRIP meter, or engine hour, or EFI fault code, or battery voltage, or dashboard brightness, or EPS fault code.

23. Gear Position Indicator

Displays the current gear position.

24. Engine RPM

Indicate the engine current RPM.

CONTROLS AND FEATURES

Dashboard Navigation / Settings / Adjustments					
Item	Displays	SEL	ADJ	Operation	Result
Odometer	Total Distance	Short press		Shifts to trip	Trip
Trip	Trip Distance	Short press		Shifts to engine hour	Engine hour
Trip	Trip Distance		Long press	Trip resets to zero	Trip Distance Reset
Engine hour	H	Short press		Shifts to EFI fault code	EFI fault code
EFI fault code	EFI fault code	Short press		Shifts to voltage	Voltage
Voltage	U	Short press		Shifts to dashboard brightness	Dashboard brightness
Dashboard brightness	Brightness level	Short press		Shifts to odometer	Odometer
			Short press	Adjust brightness+1	L-I-g-H-5
Home interface	Home interface	Long press		Shifts to time setting	Hour setting
			Short press	Shifts to dashboard brightness	Home interface
Shifting for time setting, time format and speed unit	Hour setting	Short press		Shifts to time setting	Minute setting
			Short press	Increase 1 / press	Hour setting
			Long press	Incremental 1-24	Hour setting
	Minute setting	Short press		Shifts to time unit	12/24 time format setting
			Short press	Increase 1 / press	Minute setting
			Long press	Incremental 00-59	Minute setting
	12/24 time format setting	Short press		Shifts to unit setting	Speed unit setting
			Short press	Shifts to time format	12/24 time format setting
	Unit setting	Short press		Back to home interface	Home interface
			Short press	Shifts to speed unit	Speed unit setting

Operating Your Vehicle

Break-In Period

The break-in period for a new engine is very important. Careful treatment of a new engine at the beginning of ownership will result in more efficient performance and longer life. Perform the following procedures carefully:

1. Select an open area that allows room to familiarize yourself with vehicle operation and handling.
2. Place vehicle on level ground.
3. Fill the fuel tank with gasoline.
4. Check the engine oil level. Add the recommended oil if necessary to maintain the oil level between the minimum and maximum indicators on the dipstick.
5. Position yourself in the operating position on the vehicle, fasten the seatbelt and safety nets or side doors, and start the engine. Allow the engine to idle for a short period before operating.
6. Press the foot brake, select the desired gear, and then release the foot brake.
7. Apply throttle. Drive slowly at first, varying throttle positions not more than $\frac{1}{2}$ throttle for 10 hours or 100 miles (whichever interval arrives first), then another 10 hours or 100 miles of not more than $\frac{3}{4}$ throttle (whichever interval arrives first). Do not operate at sustained idle or sustained wide open throttle.
8. Do not pull or carry any heavy loads during the break-in period.
9. Periodically check coolant level, controls, etc. along with the items outlined in the periodic maintenance chart.
10. At the end of the break-in period, change the oil and filter (20 hours or 200 miles / 320 km).

OPERATING YOUR VEHICLE

⚠ CAUTION

During the break-in period:

- Do not operate at sustained full throttle. Damage to engine parts or decrease engine life may result if excessive wide open throttle is used during the first 20 hours or 200 miles / 320 km of use.
- Do not run engine with throttle over 1/2 open during the first 10 hours (or 100 miles/160km) of use.
- Do not run engine with throttle over 3/4 open during the next 10 hours (or the second 100 miles/160km) of use.
- Do not haul or tow heavy cargo.
- Use of any oil other than those recommended may cause serious engine damage. CFMOTO recommends the use of 5W-40 for 1-cylinder 4-stroke engines. Changing engine oil viscosity to 10W-40 or 15W-40 due to hot environments is acceptable. Reference the chart below for ambient temperature and viscosity choice.

Recommended Engine Oil Viscosity

Oil Viscosity			15W-40						
				10W-40					
					5W-40				
F°	-22	-4	14	32	50	68	86	104	
C°	-30	-20	-10	0	10	20	30	40	

OPERATING YOUR VEHICLE

Pre-Ride Inspection

Before each use of the vehicle, a best practice is to check the vehicle according to the “Perform daily before operating the vehicle” checklist in the maintenance section of this manual.

WARNING

If a proper inspection is not done before each use, severe damage to the vehicle, severe injury, or death could result. Always inspect the vehicle before each use to ensure it is in proper operating condition.

Throttle

Before starting the engine, check the throttle pedal to be sure it is operating smoothly. Make sure it returns to the idle position as soon as the pedal is released. Regulate the speed of the vehicle by varying the throttle position. Because the throttle pedal is an electrically operated mechanism controlled by an ECU, the vehicle will decelerate and the engine should return to idle speed any time your foot is removed from the throttle pedal.

OPERATING YOUR VEHICLE

Foot Brake

Before operating the vehicle, push down on the pedal to apply the front and rear brakes. When pressed, the lever or pedal should feel firm. A soft brake pedal would indicate a possible fluid leak or low master cylinder fluid level, which must be corrected before riding. Contact your dealer for proper diagnosis and repairs.

Starting the Engine

 **WARNING**

Never run an engine in an enclosed area. Engine exhaust contains poisonous carbon monoxide and can cause loss of consciousness, resulting in severe injury or death.

Starting a Cold Engine

1. Verify the gear selector is shifted to the Parking or Neutral position.
2. Apply the foot brake.
3. Press the engine stop switch and main key switch to “” (ON).
4. Verify the throttle is completely closed, then turn the key start switch.
5. Once the engine starts, continue to warm the engine for a short period before operating the vehicle.

OPERATING YOUR VEHICLE

NOTE:

Do not activate the starting system more than 10 seconds on each attempt. If the engine fails to start, release the start switch, pause a few seconds before the next attempt, then try the start switch again. Each attempt should be as short as possible to preserve battery energy.

The engine can only be started when the vehicle is at the neutral gear or parking gear. If the neutral indicator light on the dashboard does not come on when the gear selector is in the neutral position, contact your dealer to inspect the indicator electrical circuit or adjust the gear shifting system.

CAUTION

Allow the engine to warm up for a short period before operating the vehicle. Operating the vehicle immediately after starting could cause engine damage.

If the vehicle can not be started immediately, do not activate the starting system continuously. Failure to start the ignition system multiple times may cause the starting motor to burn out.

Shifting the Transmission

CAUTION

To avoid transmission damage, return the throttle to the closed position, stop the vehicle, and apply the foot brake before shifting.

NOTE:

Low gear is the preferred transmission gear selection when:

- Constant driving speeds are lower than 19 mph (30kph)
- Driving on level road surfaces, and the vehicle is carrying/towing more than 584 lb. (265kg)

OPERATING YOUR VEHICLE

Shifting Out of Park

1. Verify the throttle is closed.
2. Apply the foot brake and press the gear selector button.
3. Shift to the desired gear by moving the gear selector along the shift guide.

Shifting: Neutral to High Gear

1. Verify the throttle is closed and the vehicle is stopped completely.
2. Apply the foot brake.
3. Shift to 'H' by moving the gear selector along the shift guide.

Shifting: High Gear to Low Gear

1. Verify the throttle is closed and the vehicle is stopped completely.
2. Apply the foot brake.
3. Shift to 'L' by moving the gear selector along the shift guide.

OPERATING YOUR VEHICLE

Shifting: Low Gear to High Gear

1. Verify the throttle is closed and the vehicle is stopped completely.
2. Apply the foot brake.
3. Shift to 'H' by moving the gear selector along the shift guide.

Shifting: to Reverse Gear

1. Verify the throttle is closed and the vehicle is stopped completely.
2. Apply the foot brake and press the gear selector button.
3. Shift to 'R' by moving the gear selector along the shift guide.
4. Check behind you for people or obstacles, then release the rear brake pedal.
5. Apply the throttle lever gradually and continue to watch behind you while moving backward.

WARNING

Before shifting into reverse, make sure there are no obstacles or people, and the area is safe behind you. When it is safe to proceed, go slowly.

Avoid excessive throttle operation while in speed limit mode, as it may cause fuel to build in the exhaust, resulting in engine popping and/or engine damage.

OPERATING YOUR VEHICLE

Shifting: to Park

1. Verify the throttle is closed and the vehicle is stopped completely.
2. Apply the foot brake and press the gear selector button.
3. Shift to 'P' by moving the gear selector along the shift guide. Shake the vehicle forward and backward to verify that parking is engaged.

NOTE:

- The gear shift indicators should display corresponding to the actual gear position, if the indicator does not display, ask your dealer to inspect the vehicle electrical circuit or adjust the gear shifting system.
- Due to the synchronizing mechanism in the engine, an indicator may not display until the vehicle starts moving.
- Do not use high gear for continuous slow speed travel or towing, as this can lead to excessive heating of the clutch system, which may damage components.

Safe Operation - Driving Safely

Responsibilities of the Operator

As the operator of this vehicle, your common sense, judgment, and abilities are the only factors that will prevent injury to yourself, to others around you, and/or damage to the vehicle or environment.

Recreational, Group, and Distance Riding

One of the benefits of this vehicle is that it can take you off-road away from most communities. Stay away from areas designated for other types of off-road use unless it is specifically allowed. This includes snowmobile trails, equestrian trails, cross-country ski trails, mountain bike trails, etc. Join a local ATV club. A club can provide you with a map and advice, or inform you about areas where you can ride.

Always keep a safe distance from other riders ahead of you and behind you when riding in a group. Never operate carelessly or make unexpected maneuvers with other vehicles close by. Stay on designated trails and riding areas, and discourage others from operating in unauthorized locations.

Avoiding Accidents, Rollovers and Tip-overs

- Utility terrain vehicles handle differently from other vehicles. Utility terrain vehicles are designed to handle off-road terrain (for example, the wheel base and track width, ground clearance, suspension, drive train, tires, etc.) and as a result, can overturn in situations where vehicles designed for use primarily on paved or smooth terrain may not.

A rollover or other accident can occur quickly during abrupt maneuvers such as:

- Sharp turns or hard acceleration.
- Deceleration when turning.
- When driving on hills or over obstacles.

SAFE OPERATION - DRIVING SAFELY

Abrupt maneuvers or aggressive driving can cause rollovers or loss of control even in flat open areas. If the vehicle rolls over, any part of your body (such as arms, legs, or head) outside of the cockpit can be crushed and trapped by the cage or other parts of the vehicle. You can also be injured by impact with the ground, cab, or other objects.

To reduce the risk of rollovers:

- Use care when turning.
- Adjust steering inputs accordingly to your speed and environment.
- Slow down before entering a turn.
- Avoid hard braking during a turn.
- Avoid sudden or hard acceleration when turning, even from a stop or low speed.
- Never attempt donuts, skids, slides, fishtails, jumps, or other stunts.
- If vehicle starts to skid or slide, steer in the direction of the skid or slide.
- Never slam the brakes and lock the wheels.
- This vehicle is built primarily for OFF-ROAD purposes. Riding on paved surfaces may seriously affect vehicle handling and control. If you must drive on paved surfaces for a short distance, reduce speed and avoid abrupt inputs to steering wheel, accelerator and brake pedals.

This vehicle can roll over sideways, or tip over forward or backwards on slopes or uneven terrain:

- Avoid side hilling (driving along the slope rather than up or down a hill). When possible, drive straight up and down inclines rather than across them. If you must side hill, use extreme caution and avoid slippery surfaces, objects, or depressions. If you feel the vehicle start to rollover or slide sideways, steer downhill if possible.
- Avoid steep hills and follow procedures in this manual for climbing and descending hills.

SAFE OPERATION - DRIVING SAFELY

- Sudden changes in terrain such as holes, depressions, banks, softer or harder ground or other irregularities may cause the vehicle to tip or become unstable. Observe the terrain ahead and slow down in areas of uneven terrain.

This vehicle will handle differently when carrying or pulling a load:

- Reduce speed and follow instructions in this manual for carrying cargo or pulling a trailer.
- Avoid hills and rough terrain.
- Allow more distance to stop.

Be prepared in case of rollover:

- Latch side doors or side nets and fasten seat belts to help you avoid sticking out arms or legs.
- Never grab the cage while riding. Hands can be crushed between the cage and the ground in a rollover. Keep hands on the steering wheel or handhold.
- Never try to stop a rollover using your arms or legs. If you think that the vehicle may tip or roll, the driver should keep both hands on the steering wheel and both feet firmly planted on the floor. The passenger should keep both hands on the handhold and both feet firmly planted on the floor.

Avoiding Collisions

At higher speeds, there is an increased risk of losing control, particularly in challenging off-road conditions, and the risk of injury in a collision is greater. Never operate at excessive speeds. Always go at a speed that is proper for the terrain, visibility, and operating conditions, and your experience. This vehicle does not have the same kind of protection for collisions as a car; for example, there are no air bags, the cab is not fully enclosed, and it is not designed for collisions with other vehicles. Therefore, it is particularly important to fasten seat belts, latch side doors or side nets, and wear proper riding gear.

SAFE OPERATION - DRIVING SAFELY

Environment

Off-road recreation is a privilege. Maintain your privilege by respecting the environment and the rights of others to enjoy it:

- Chasing wildlife is illegal. Wildlife can die of exhaustion if chased by a motorized vehicle.
- Never purposely damage the terrain unless the operating area is designated for that type of activity.
- Observe the rule... "what you take in, carry out". Do not litter.

Practice Exercises

Before you go out for a ride, it is very important to familiarize yourself with the handling of your vehicle by practicing in a controlled environment. Find a suitable area to practice and perform the following exercises. It should be at least 147 ft × 147 ft. (45 m × 45 m), and free of obstacles like trees and large rocks.

Remember: Avoid higher speeds until you are thoroughly familiar with the operation of your vehicle.

NOTE:

Low gear is the preferred transmission gear selection when:

- Constant driving speeds are lower than 19 mph (30kph)
- Driving on level road surfaces, and the vehicle is carrying/towing more than 584 lb. (265kg)
- Driving on muddy or rough road surfaces, and the vehicle is carrying/towing more than 430 lb. (195kg)

SAFE OPERATION - DRIVING SAFELY

Turning Exercise

Turning is one of the most frequent causes of accidents. It is easier for the vehicle to lose traction or rollover if you turn too sharply, or go too fast. Slow down when you approach a turn.

Practice turning:

- First, learn how to perform slight right turns at very low speeds. Release the throttle before turning and slowly reapply the throttle.
- Repeat the turning exercise, but this time maintain the throttle at the same level while turning.
- Finally, repeat the turning exercise while accelerating slowly.
- Practice exercises turning to the left.

Note how your vehicle reacts in these different exercises. CFMOTO recommends releasing the throttle before entering a turn to help initiate directional change. You will feel the lateral force increasing with the speed and with your steering input. The lateral force should be maintained as low as possible to make sure it does not cause the vehicle to roll over.

U-turn Exercise

Practice doing U turns:

- Accelerate slowly and while remaining at low speed, gradually turn the steering wheel to the right until you have completed the U-turn.
- Repeat U-turn exercise with different steering inputs and always at a very low speed.
- Repeat U turn exercise to the left.

As mentioned before in this manual, do not ride on paved surfaces. The vehicle behavior will not be the same, increasing the risk of rollover.

SAFE OPERATION - DRIVING SAFELY

Braking Exercise

Practice braking to get familiar with the brake response:

- Practice braking at low speed first, then increase the speed.
- Practice braking in straight line at different speeds and different braking forces.
- Practice emergency braking. Optimal braking is obtained in straight line, with high force applied, without locking the wheels.

Remember, braking distance depends on vehicle speed, load and the type of surface. Also, the tires and brakes conditions play a major role.

Reverse Exercise

Practice using the reverse:

- Place 1 cone marker on both sides of the vehicle beside each rear wheel.
- Move the vehicle forward until you can see the cone markers behind you, then stop the vehicle. Acknowledge the distance required to see obstacles behind you.
- Learn how the vehicle handles in reverse and reacts with steering inputs.
- Always perform this reverse exercise at slow speeds.

Emergency Engine Stopping Exercise

Learn how to stop your engine quickly in an emergency situation:

- While running at low speed, simply turn the ignition key to the off position. This is to familiarize you with the vehicle's reaction when the engine is turned off while driving and to develop this reflex.

SAFE OPERATION - DRIVING SAFELY

Operating Your Vehicle

Off-Road Operation

The very nature of off-road operation is dangerous. Any terrain which has not been specially prepared to carry vehicles presents an inherent danger where terrain substance, shape, and steepness are unpredictable. The terrain itself presents a continual element of danger, which must be knowingly accepted by anyone venturing over it.

An operator who takes a vehicle off-road should always exercise the utmost care in selecting the safest path and keeping close watch on the terrain ahead. This vehicle should never be operated by anyone who is not completely familiar with the driving instructions applicable to the vehicle, nor should it be operated on steep or treacherous terrain.

General Driving Tips

Care, caution, experience and driving skill are the best precautions against the hazards of vehicle operation. Whenever there is the slightest doubt that the vehicle can safely negotiate an obstacle or a particular piece of terrain, always choose an alternate route. In off-road operation, power and traction, not speed, are important. Never drive faster than visibility and your ability to select a safe route permit. Never operate the vehicle if the controls do not function normally. See your dealer.

Operating in Reverse

When operating in reverse, check that the path behind the vehicle is free of people or obstacles. Pay attention to blind spots. When it is safe to proceed in reverse, go slowly and avoid sharp turns.

 WARNING
--

Steering inputs in reverse operation increase the risk of rollover.

SAFE OPERATION - DRIVING SAFELY

WARNING

When driving downhill in reverse, gravity can increase the vehicle speed above the set limited reverse speed. Failure to use caution when operating in reverse can result in serious injury or death.

NOTE:

This vehicle is equipped with a reverse speed limiter function. In reverse operation, the engine RPM is limited, thus limiting the vehicle reverse speed. Do not operate at wide open throttle. Open the throttle just enough to maintain a desired speed.

Crossing Paved Roads

If you have to cross a paved road, ensure to have complete visibility on both sides for incoming traffic and decide on exit point on other side of road. Drive in a straight line toward that point. Do not make sharp direction changes or abrupt accelerations as it may result in a rollover situation. Do not travel on sidewalks or bicycle trails, as they are designated specifically for those uses.

Riding on Paved Surfaces

Avoid paved surfaces. This vehicle is not designed to operate on paved surfaces and is more likely to roll over. If you must drive on pavement, turn gradually, go slowly, and avoid abrupt acceleration and braking.

Shallow Water Crossing

Water can be a unique hazard. If it is too deep the vehicle may “float” and topple. Check the water depth and current before you attempt to cross any water. Water depth should not exceed the bottom of the floorboard to safely cross the obstacle.

SAFE OPERATION - DRIVING SAFELY

Beware of slippery surfaces such as rocks, grass, logs, etc., both in the water and on its banks. A loss of traction may occur. Do not attempt to enter the water at high speed. Water will affect the braking ability of your vehicle. Make sure you dry the brakes by applying them several times while driving slowly after the vehicle leaves the water.

What to Do If Vehicle is Submerged

If the vehicle becomes immersed, it will be necessary to have it transported to your dealer as soon as possible. Do not attempt to re-start the engine, as water may have been ingested into the engine, which can cause internal damage.

Riding in Mud, Ice or Snow

When performing a pre-ride inspection, pay special attention to locations on the vehicle where mud, ice and/or snow accumulations may obstruct visibility of the tail lamps, clog ventilation openings, block the radiator and fan, and interfere with the movement of controls. Before starting with your vehicle, check the steering, throttle and brake pedals for interference-free operation.

Whenever this vehicle is driven on a snow or ice covered path, the tire grip is generally reduced, causing the vehicle to react differently to control inputs from the operator.

Riding on Sand

Sand and riding on sand dunes is a unique experience, but there are some basic precautions that should be observed. Wet, deep, or fine sand may create a loss of traction and cause the vehicle to slide, drop off or become “bogged” down. If this occurs, look for a firmer base. Again, the best advice is to slow down and be watchful of the conditions.

When riding on sand dunes, it is advisable to equip the vehicle with an antenna-type safety flag. This will help make your location more visible to others over the next sand dune. Proceed carefully should you see another safety flag ahead.

SAFE OPERATION - DRIVING SAFELY

Riding on Gravel, Loose Stones, or Other Slippery Surfaces

Riding on gravel or loose stones is very similar to riding on ice. They affect the steering of vehicle, possibly causing it to slide and tip over especially at high speeds. In addition, braking distance may be affected. Remember that “gunning” the throttle or sliding may cause loose stones to be ejected rearwards which could hit other people.

Crossing Obstacles

Obstacles on the trail should be traversed with caution. This includes rocks, fallen trees, and depressions. You should avoid them whenever possible. Remember that some obstacles are too large or dangerous to cross and should be avoided. As a guideline, never attempt to cross an obstacle higher than the ground clearance of the vehicle. Small rocks or small fallen trees may be safely crossed. Approach obstacles at low speed and to as much a right angle as possible. Adjust speed without losing momentum and do not accelerate abruptly. The passenger must grasp handhold firmly and brace feet on the floor.

Hill Driving Conditions

When driving on hills or slopes, two things are highly important: be prepared for slippery surfaces or terrain variations, obstacles, and brace yourself properly inside vehicle. If you climb or descend a hill that is too slippery or has too loose a surface, you can lose control. If you go over the top of a hill at high speed, you may not have time to prepare for the terrain on the other side. Avoid parking on a slope. Always put the shift lever in PARK and activate the hand brake when stopped or parked, especially on an incline, to avoid rolling. If you must park on a steep incline, block the wheels on the downhill side using rocks or other suitable material.

SAFE OPERATION - DRIVING SAFELY

Uphill Driving

Use the low gear (L) for uphill driving. Due to its configuration, this vehicle has very good traction even while climbing, so much so that tip-over is possible before traction is lost. For example, it is common to encounter terrain situations where the top of the hill has eroded to a point that the hill peak rises very sharply. This vehicle is not designed to negotiate such a condition. Take an alternate route.

If you feel that the slope is getting too steep to climb, apply the brakes to immobilize the vehicle. Put the shift lever in reverse (R), and back straight down the hill, barely releasing brakes to remain at low speed. Do not attempt to turn around. Never coast downhill while the vehicle is in neutral. Do not perform hard braking, as it increases the risk of tip-over.

Downhill Driving

This vehicle can climb steeper slopes than it can descend safely. Therefore, it is essential to assure that a safe route exists to descend a slope before you climb it. Decelerating while negotiating a slippery downhill slope could “toboggan” the vehicle, causing it to slide. Maintain steady speed and/or accelerate slightly to regain control. Never slam the brakes and lock the wheels.

SAFE OPERATION - DRIVING SAFELY

Hauling and Towing Loads

Your vehicle can help you perform a number of different light tasks ranging from snow removal, to pulling wood, or carrying cargo. This can change the vehicle handling. To prevent possible injury, follow the instructions and warnings in this manual and on the vehicle.

Always respect the load limits of the vehicle. Overloading the vehicle can over-stress the components and cause failure.

Carrying Loads

The load limit of the vehicle including the weight of operator, passenger, cargo, accessories and trailer towing hitch weight: 1500 lb. (680kg)

Following is an example of suitable total vehicle load distribution:

EXAMPLE OF SUITABLE VEHICLE TOTAL LOADS				
Operator and Passenger	Cargo Box Load	Accessories Storage	Towing Hitch Weight	Total Vehicle Load
352.7 lb. (160 kg)	551.2 lb. (250 kg)	11 lb. (5 kg)	55.1 lb. (25 kg)	1500lb. (680kg)

WARNING

Low gear is the preferred transmission gear selection when:

- Constant driving speeds are lower than 19 mph (30kph)
- Driving on level road surfaces, and the vehicle is carrying/towing more than 584 lb. (265kg)
- Driving on muddy or rough road surfaces, and the vehicle is carrying/towing more than 430 lb. (195kg)

SAFE OPERATION - DRIVING SAFELY

Vehicle Settings When Carrying Loads

If the total load approaches 1500 lb. (680 kg), including weight of operator, passenger, cargo, accessories and trailer Towing Hitch Weight:

- Inflate the tires to maximum pressure: Front: 11 PSI (80 kPa), rear : 17 PSI (120 kPa).
- Readjust the suspension coil spring pre-load accordingly.
- Operate with the shift lever in L (low gear) when carrying heavy loads in the cargo box and/or pulling a trailer.

Load Distribution

Your vehicle has been designed to carry or tow a certain amount of load. Always:

- Read and understand the load distribution warnings listed on the warning labels.
- Never exceed the specified weights.
- Cargo weight should be mounted as low as possible.
- When operating over rough or hilly terrain with loads or towing, reduce speed and cargo to maintain stable driving conditions.

Pulling or Towing

Your vehicle is equipped with a hitch receptacle and winch for towing or pulling.

Pulling a Load

- Never pull a load by attaching it to the cage. This can cause the vehicle to tip over. Use only the trailer hitch or winch (if installed) to pull a load.
- When pulling loads with a chain or cable, ensure that there is no slack before starting and maintain tension while pulling.

SAFE OPERATION - DRIVING SAFELY

WARNING

Slack can cause a chain or cable to break and snap back, possibly causing injury.

- When pulling a load, respect the maximum hauling capacity.
- If pulling another vehicle, be sure that someone is controlling the pulled vehicle. They must brake and steer to prevent the vehicle from going out of control.
- Reduce your speed when pulling a load and turn gradually to avoid chains, straps, ropes or cables from catching on the rear wheels. Avoid hills and rough terrain. Never attempt steep hills. Allow more distance for braking, especially on inclined surfaces. Be careful not to skid or slide.
- Before pulling loads with a winch, refer to the winch Owner's Manual.

Towing a Load

If a trailer is used behind the vehicle, make sure that its hitch is compatible with the one on the vehicle. Make sure the trailer is horizontal with the vehicle. Use safety chains or cables that keep the trailer secured to the vehicle in the event of a hitch failure.

Improperly loading a trailer may cause loss of control. Respect the recommended maximum hauling capacity and maximum tongue load. Make sure there is at least some weight on the tongue. Follow these guidelines for hauling and towing of cargo:

WARNING

Overloading the vehicle, carrying or towing cargo improperly, can alter the vehicle handling and may cause loss of control or braking instability.

SAFE OPERATION - DRIVING SAFELY

- Always use low gear while towing to avoid clutch wear and belt issues.
- Reduce speed when hauling or towing loads.
- Never exceed the stated load capacity for this vehicle.
- All loads must be secured before operation. Unsecured loads may shift and create unstable operating conditions, which could result in loss of control of the vehicle.
- When operating over rough or hilly terrain, reduce speed and cargo to maintain stable driving conditions.
- Use extreme caution when applying brakes with a loaded vehicle. Avoid terrain or situations that may require backing downhill.
- Load weight distribution should be as low as possible. Carrying a high load raises the center of gravity and creates an unstable operating condition. Reduce load weight when the cargo center of gravity is high.
- When handling off-centered loads that cannot be centered, secure the load and operate with extra caution.
- When operating with loads extending beyond the cargo area, stability and maneuverability may be adversely affected, causing the machine to overturn.
- Towing a load while carrying cargo may cause an imbalanced condition that increases the possibility of vehicle overturn. Balance loads proportionally, but do not exceed the stated load capacity.
- Always attach to the tow using the hitch point and hardware specifically made for towing. Never exceed the recommended Towing Hitch Weight.
- Using chains, straps, rope or other materials to tow objects is not recommended, as these items could get caught in the rear wheels, resulting in vehicle damage or personal injury.

SAFE OPERATION - DRIVING SAFELY

- While towing, the vehicle should never exceed 10 mph (16 km/h) towing a load on a level surface. Vehicle speed should never exceed 5 mph (8 km/h) when towing loads in rough terrain, while cornering, or while ascending or descending a hill.
- When stopped or parked, block the vehicle and trailer wheels from possible movement.
- Use caution when disconnecting a loaded trailer; it or its load may topple on you or others.

MAXIMUM HAULING CAPACITY			
Type of Attachment	Trailer Load Allowed	Trailer Hitch Weight Allowed	Note
2 in. (51 mm × 51 mm) hitch ball support	1500 lb. (680.4 kg)	150 lb. (68kg)	Includes trailer and trailer load

SAFE OPERATION - DRIVING SAFELY

Winch Operation

(Select Markets) Your vehicle may be equipped with a winch that can pull certain capacities and types of loads. It is useful for vehicle self-recovery when stuck, assisting another vehicle in recovery, moving fallen trees, removing brush, etc.

Consider practicing the operation and use of your winch before you actually need to use it.

The safety warnings, operating precautions and instructions in this section apply if your vehicle came equipped with a winch, or if you choose to install an accessory winch on your vehicle:

Winch Safety Warnings

These safety warnings apply if your vehicle is equipped with a winch, or if you choose to install an accessory winch on your vehicle:

- Read and understand all sections of this manual.
- Improper winch use or failure to correctly follow the winch guidelines, instructions, and warnings in this manual can result in SEVERE INJURY or DEATH.
- Improper or lack of winch maintenance and service could lead to SEVERE INJURY or DEATH.
- Always keep body, hair, clothing, and jewelry clear of the winch cable, fairlead, and hook during winch operation.
- Always keep the area around the vehicle, winch, winch cable and load clear of people, pets, and distractions during winch operation.
- Always wear eye protection and heavy gloves during winch operation.
- Never use alcohol or drugs before or while operating the winch.

SAFE OPERATION - DRIVING SAFELY

- Never allow children under 16 years of age to operate the winch.
- Never attempt to “jerk” a load attached to the winch by moving the vehicle.
- Never winch up or down, or to the sides at sharp angles. This can destabilize the winching vehicle and possibly cause it to move without warning.
- Never attempt to winch loads that weigh more than the winch capacity rating.
- Never touch, push, pull, or straddle the cable while winching a load.
- Never let the winch cable run through your hands, even if wearing heavy gloves.
- Never release the drum on the winch when the winch cable is under load.
- Never use the winch for lifting or transporting people.
- Never use the winch to hoist or suspend a vertical load.
- Never retract the hook fully into the winch. This can cause damage to system components.
- Never operate the winch or the vehicle if they are in need of repair or service.
- Always turn the ignition switch OFF and unplug the remote control (if equipped) to prevent inadvertent activation or unauthorized use when the vehicle or winch are not being used.

Winch Operating Precautions

These operating precautions should always be followed if your vehicle is equipped with a winch, or if you choose to install an accessory winch on your vehicle:

- Always inspect your winch and winch cable before each use.
- Always use the provided hook strap when pulling cable out or guiding cable in. Never grab the hook.
- Always align the load directly in front of the vehicle and winch as much as possible. Avoid winching with the cable at a sharp angle to the winching vehicle’s centerline whenever possible.

SAFE OPERATION - DRIVING SAFELY

If winching at an angle is unavoidable, follow these precautions while operating:

- A. Look at the winch drum occasionally. Never let the winch cable “stack” or accumulate at one end of the drum. Too much cable at one end of the drum can damage the winch and cable.
- B. If cable stacking occurs, stop winching. Follow the ‘Winch Cable Spooling Guidelines’ section in this manual to redistribute the cable evenly before continuing.
- Always apply the vehicle’s park brake and/or park mechanism to hold the vehicle in place during winching. Use wheel chocks when necessary.
- Always maintain at least five full turns of cable wrapped around the winch drum at all times. The friction provided by the wrapped cable allows the drum to pull on the winch cable and move the load.
- Never grease or oil the winch cable. This will cause the winch cable to collect debris that will shorten the life of the cable.
- The winch motor and relay connector may become hot during continuous use. When winching for more than 45 seconds, or if the winch stalls during operation, stop and allow the winch components to cool for a minimum of 10 minutes before using it again.
- Never operate the winch without running the engine. The engine’s charging system helps keep the battery maintained. Battery reserve capacity can be quickly exhausted by heavy winch use, rendering the starting system inoperable.
- Always operate with concern for the environment. Do not purposely damage trees, etc.

Basic Winch Operation

Follow these operating instructions if your vehicle is equipped with a winch, or if you choose to install an accessory winch on your vehicle. Read *Winch Safety Warnings and Winch Operating Precautions* on the preceding pages before using your winch.

SAFE OPERATION - DRIVING SAFELY

BEFORE YOU BEGIN - Realize that each winching situation is unique:

- Take your time to think through the winch operation you are about to perform.
 - Proceed slowly and deliberately.
 - Never hurry or rush during winching.
 - Always pay attention to your surroundings.
 - Be prepared to change your winching strategy if it is not working.
 - Remember that although your winch is very powerful, there are simply some situations that you and the winch will not be able to deal with. Do not be afraid to ask others for help when necessary.
1. Always inspect the vehicle, winch, cable and controls for signs of damage or parts in need of repair before each use. Pay particular attention to the first 3 feet (1 meter) of winch cable if the winch is used (or has been used) for lifting a plow. Promptly replace any worn or damaged cable.
 2. Apply the vehicle's park brake and/or park mechanism to hold the vehicle in place during winching. Use wheel chocks when necessary.
 3. Release the winch drum and pull out the required length of cable. Always use the hook strap to handle the hook. Never remove the hook strap from the hook.

CAUTION: Always maintain a minimum of five (5) full turns of cable around the winch drum at all times. The friction provided by wrapping cable allows the drum to pull on the cable and move the load.

4. Attach the hook onto the load, or use a tow strap or chain to secure the load to the winch hook. Never hook the winch cable back onto itself. This can damage the winch cable and result in cable failure.

SAFE OPERATION - DRIVING SAFELY

WARNING: Never use a 'recovery strap' for winching. Recovery straps are designed to stretch and could release excessive energy that can result in SEVERE INJURY or DEATH if the strap or winch cable breaks. Use only undamaged tow straps or chains that do not stretch.

5. Re-engage the winch drum.
6. Slowly winch in slack of the winch cable until it is gone, then stop and follow the instructions for 'winch damping' to ensure safe operation:
 - A. Place a damper on the mid-point of winch cable length to absorb energy that could be released by a winch cable failure. A damper can be a heavy jacket, tarp, or other soft, dense object. A damper can absorb much of the energy released if the cable breaks during winching. Even a tree limb can help as a damper if no other items are available to you.
 - B. Lay the damper on top of the mid-point of the winch cable length.
 - C. On a long pull, it may be necessary to stop winching so the damper can be repositioned to a new mid-point. Always release the tension on the winch cable before repositioning the damper.
 - D. Avoid being directly in line with the winch cable whenever possible. Also, never permit others to stand near or in line with the winch cable during winch operation.
7. Stop winching as soon as the job is completed or the load can be moved without the help of the winch.
8. Detach the winch hook, then rewind the cable evenly back onto the drum following the instructions in this manual.

SAFE OPERATION - DRIVING SAFELY

Vehicle Recovery Methods

Vehicle Self-Recovery:

- A. Release the winch drum and pull out the required length of cable.
- B. Whenever possible, pick an anchor point that aligns the winch cable to the vehicle's centerline as close as possible. This will help the spooling of the winch cable and reduce the load on the fairlead.
- C. Attach the winch hook to an anchor point. NOTE: If freeing a stuck vehicle by attaching to a tree, use an item such as a tow strap to avoid damaging the tree during winch operation. Sharp cables and chains can damage and even kill trees. Always respect the environment.
- D. Re-engage the winch drum.
- E. Slowly winch in any slack in the winch cable, then damper it.
- F. Shift to the lowest gear available that will propel the vehicle in the direction of winching.
- G. Carefully apply winch power and throttle together to free the vehicle.

CAUTION: Using the vehicle throttle and winching at the same time has risk and is optional. Place the vehicle in neutral and use only the winch if unsure of your operating abilities.

- H. Stop winching as soon as the stuck vehicle is able to propel itself without the help of the winch.
- I. Detach the winch hook, then rewind the cable evenly back onto the drum following the instructions in this manual.

CAUTION: The ONLY time a winch-equipped vehicle should be moving and using the winch is for self-recovery. The winch-equipped vehicle should NEVER use motion to “shock-load” the winch cable in an attempt to recover a second stuck vehicle. See ‘Winch Shock Loading’ section in this manual for more information.

SAFE OPERATION - DRIVING SAFELY

Recovery of Another Vehicle:

- A. Release the winch drum and pull out the necessary length of cable.
- B. Attach the winch hook to the vehicle. Whenever possible, pick an anchor point on the stuck vehicle that aligns the winch cable to the winching vehicle's centerline as close as possible. This will help the spooling of the winch cable and reduce the load on the fairlead.

CAUTION: Never attach the winch hook to a suspension component, brush guard, bumper or cargo rack. Vehicle damage may result. Always attach the hook to the strongest available portion of the vehicle frame or hitch.

- C. Re-engage the winch drum.
- D. Slowly winch in any slack in the winch cable, then damper it.
- E. Shift to the lowest gear available on the stuck vehicle that will propel it in the direction of winching.
- F. Carefully apply winch power and the stuck vehicle's throttle together to free it.
- G. Stop winching as soon as the stuck vehicle is able to propel itself without the help of the winch.
- H. Detach the winch hook, then rewind the cable evenly back onto the drum following the instructions in this manual.

Winch Cable Care

Always inspect your winch cable before each use for worn or kinked winch cable. Never use a cable that is damaged. Follow these guidelines for inspection and use:

- A winch cable made of wire rope that is kinked, deformed, or bent is permanently and severely damaged. Promptly discontinue use of a winch cable in this condition.

SAFE OPERATION - DRIVING SAFELY

- A kinked winch cable made of wire rope that has been “straightened out”, even though it may look usable, has been permanently and severely damaged. It can no longer achieve its load capacity rating. Promptly discontinue use of a winch cable in this condition.
- A winch cable made of synthetic rope should be inspected for signs of fraying. Replace the cable if fraying is observed. Promptly discontinue use of a winch cable in this condition.
- Replace synthetic winch cable if fused or melted fibers are discovered. The synthetic rope will be stiff and appear smooth or glazed in the damaged section. Promptly discontinue use of a winch cable in this condition.
- Never replace a synthetic winch cable with consumer-grade polymer rope. Only use cable that is specifically designed for winch use.
- Never grease or oil a wire rope winch cable. This will cause the cable to collect debris that will shorten the life of the cable.
- Never operate the winch with a damaged hook or latch. Always replace damaged parts before using the winch.

WARNING: Replace the winch cable and components at the first sign of damage to prevent SEVERE INJURY or DEATH in the event of failure.

Winch Cable Spooling Guidelines

After winching is complete, especially if winching at an angle, it may be necessary to respool the winch cable evenly across the drum. This reduces the chances of the winch cable “wedging” itself between lower layers of cable. You will need an assistant to perform this task:

- A. Release the winch drum.

SAFE OPERATION - DRIVING SAFELY

- B. Pull out the winch cable that is wrapped unevenly onto the drum.
- C. Re-engage the winch drum.
- D. Have an assistant pull the winch cable hook strap tightly to apply about 100 lbs. (45 kg) of tension.
- E. Slowly winch the cable in while the assistant moves the end of the cable back and forth horizontally to evenly distribute it onto the drum.

Winch ‘Shock Loading’

Your winch (if equipped) is designed and tested to withstand the loads produced when operated from a stationary vehicle. Always remember that the winch, cable and components are NOT designed for shock loading. Follow these guidelines:

- Never attempt to “jerk” a load with the winch. For example, never take up cable slack by moving the winching vehicle in an attempt to move an object. This is a dangerous practice that generates high loads which may exceed the strength of the components. Even a slow moving vehicle can create a large shock load which can cause damage.
- Never quickly turn the winch ON and OFF repeatedly (“jogging”). This is a form of shock loading. This puts extra load on the winch components, the cable, and generates excessive heat in the motor and relay assembly.
- Never tow a vehicle or other object with your winch. Towing with a winch produces shock loading even when towing at slow speeds. Towing from the winch also positions the towing force high on the vehicle, which can cause vehicle instability and the possibility of an accident.

SAFE OPERATION - DRIVING SAFELY

- Never use recovery straps with your winch. This is a form of shock loading. Recovery straps are designed to stretch and can store energy. Stored energy in the recovery strap is released if a failure occurs, making the event even more hazardous. Similarly, never use elastic “bungee” cords for winching.
- Never use the winch to tie down the vehicle to a trailer or other transporting unit. This is a form of shock loading that can cause damage to the winch components, the cable, or the transporting unit.

MAINTENANCE

Maintenance

Careful periodic maintenance will help keep your vehicle in the safest, most reliable condition. Inspection, adjustment, and lubrication of important components are explained in the maintenance schedule.

Inspect, clean, lubricate, adjust, and replace parts as necessary. When inspection reveals the need for replacement parts, always use genuine parts available from your dealer.

NOTE:

Periodic service and adjustments are critical. If you are not familiar with performing safe service and adjustment procedures, have a qualified dealer perform the required maintenance for you.

Pay special attention to the engine oil level during cold weather operation. A rise in engine oil level can indicate contaminants collecting in the oil sump or crankcase. Change oil immediately if the oil level begins to rise. Monitor the oil level, and if it continues to rise, discontinue use and determine the cause, or see your dealer.

Severe Use Definition

CFMOTO defines severe vehicle use as:

- Frequent immersion in mud, water or sand
- Racing or race-style high RPM use
- Prolonged low speed, heavy load operation
- Extended engine idle
- Short trip cold weather operation
- Vehicles used in commercial operations

If your vehicle use matches any of these definitions, decrease the service intervals by 50%.

MAINTENANCE

WARNING

Procedures marked as '■' means if repair is required, have an authorized dealer perform repairs that involve this component or system. Improperly performing the procedure could result in component failure and lead to serious injury or death.

KEY POINTS OF LUBRICATION SCHEDULE:

Check all components at the intervals outlined in the Periodic Maintenance Schedule. Items not listed in the schedule should be lubricated at the general lubrication interval.

- Change lubricants more often under severe use, such as wet or dusty conditions.
- Use All Season Grease on pivot points.
- Lubricate every 500 miles (800 km), before long periods of storage, after pressure washing, or after submerging drive system.

Item	Lubricant	Method
Engine oil	SAE 10W-40 / SAE 5W-40 / SAE 15W-40	Screw off, clean, insert and pull out dipstick to check oil level
Brake fluid	DOT4	Keep level between upper and lower lines
Front gear case oil	SAE 80W-90 GL-5	Drain and fill with specified amount
Rear gear case oil	SAE 80W-90 GL-5	Drain and fill with specified amount
Suspension pivots and drive train	All Season Grease	Grease gun-Pump grease until it begins to flow from the pivot point

MAINTENANCE

Pre-Ride Maintenance Checklist

Perform these inspections before operating the vehicle:

Item		Maintenance before operation			
		Hour	Calendar	Miles (km)	Remarks
■	Steering system	-	Pre-Ride	-	Visually inspect, test, or check components. Make adjustments and/or schedule repairs when required.
■	Throttle return	-	Pre-Ride	-	
	Front suspension and axles	-	Pre-Ride	-	
	Rear suspension and axles	-	Pre-Ride	-	
	Tires	-	Pre-Ride	-	
	Brake fluid level	-	Pre-Ride	-	
	Brake lever / foot brake function	-	Pre-Ride	-	
	Brake system function	-	Pre-Ride	-	
	Wheels / fasteners	-	Pre-Ride	-	
	Engine oil level	-	Pre-Ride	-	
▶	Air filter / Air box and connections	-	Pre-Ride	-	Visually inspect. Replace filter when dirty.

▶ = Severe Use Item. Inspect frequently on vehicles subjected to severe use.

■ = Have an authorized dealer perform repairs that involve this component or system.

● = Emissions related components. Have an authorized dealer perform repairs that involve this component or system.

MAINTENANCE

Item		Maintenance before operation			
		Hour	Calendar	Miles (km)	Remarks
▶	Air box sediment tube	-	Pre-Ride	-	Inspect. If deposits are visible, clean intake tubes, air box, and replace air filter.
▶	CVT sediment tube	-	Pre-Ride	-	Inspect. If deposits are visible, drain / clean the CVT or have it serviced by a dealer.
■	Headlight aim / General lighting and turn indicators (if equipped)	-	Pre-Ride	-	Inspect. Adjust or replace lights when necessary.
▶	Radiator	-	Pre-Ride	-	Inspect for mud or debris blocking airflow. Clean surfaces when necessary.

▶ = Severe Use Item. Inspect frequently on vehicles subjected to severe use

■ = Have an authorized dealer perform repairs that involve this component or system.

● = Emissions related components. Have an authorized dealer perform repairs that involve this component or system.

MAINTENANCE

Break-In Maintenance Checklist

Perform these maintenance items when the vehicle break-in is completed:

Item		Break-in Maintenance (Perform at the interval that arrives first)			
		Hour	Calendar	Miles (km)	Remarks
	General lubrication	20	-	200 (320)	Lubricate all grease points, pivots, cables, etc.
	Engine oil / oil filter / oil strainer	20	-	200 (320)	Change oil and filter. Clean oil strainer.
▶	Engine air filter	20	-	200 (320)	Inspect; replace if dirty; do not clean
■	Engine valve clearance	20	-	200 (320)	Check and adjust as necessary.
	Front / Rear gear case oil	20	-	200 (320)	Check level. Inspect for leaks.
	Coolant	20	-	200 (320)	Check level. Inspect for leaks.
▶	Brake pad	20	-	200 (320)	Inspect the thickness.

▶ = Severe Use Item. Reduce interval by 50% on vehicles subjected to severe use.

■ = Have an authorized dealer perform repairs that involve this component or system.

● = Emissions related components. Have an authorized dealer perform repairs that involve this component or system.

MAINTENANCE

Item		Break-in Maintenance (Perform at the interval that arrives first)			
		Hour	Calendar	Miles (km)	Remarks
▶	Brake pads	20	-	200 (320)	Inspect pad thickness.
	Battery	20	-	200 (320)	Check terminals, clean, test battery condition if required.
■	Idle condition	20	-	200 (320)	Inspect for proper rpm. See dealer for service if out of spec or erratic.
■	Steering / Wheel Alignment	20	-	200 (320)	Inspect steering system. See dealer for service if wheel alignment is required.
▶	Foot brake / Hand brake	20	-	200 (320)	Inspect function. Adjust as necessary.
	Gear cases, CV shafts, Propshafts	20	-	200 (320)	Inspect for leaks.

▶ = Severe Use Item. Reduce interval by 50% on vehicles subjected to severe use.

■ = Have an authorized dealer perform repairs that involve this component or system.

● = Emissions related components. Have an authorized dealer perform repairs that involve this component or system.

MAINTENANCE

Periodic Maintenance Schedule

Perform maintenance at the interval that arrives first after the 20-hour break-in period:

Item		Periodic Maintenance Intervals (Perform at the interval that arrives first)			
		Hour	Calendar	Miles (km)	Remarks
▶	Brake pads	10	Monthly	100 (160)	Inspect pad thickness.
	Battery	20	-	200 (320)	Check terminals. Clean and test battery condition as necessary.
	Engine hoses, gaskets and seals	20	-	200 (320)	Inspect for leaks.
▶	Air filter	50h	-	500 (800)	Always inspect pre-ride. Inspect frequently if subjected to severe use. Replace if dirty. Do not clean.
▶	CVT air intake filter screen / filter	50h	-	500 (800)	Clean filter screen or filter, replace with new one if necessary.
▶	General lubrication	50h	3M	500 (800)	Lubricate all grease points, pivots, cables, etc.

▶ = Severe Use Item. Reduce interval by 50% on vehicles subjected to severe use.

■ = Have an authorized dealer perform repairs that involve this component or system.

● = Emissions related components. Have an authorized dealer perform repairs that involve this component or system.

MAINTENANCE

Item		Periodic Maintenance Intervals (Perform at the interval that arrives first)			
		Hour	Calendar	Miles (km)	Remarks
▶	Front gear case oil	100h	12M	1000 (1600)	Inspect level. Change yearly if hours or distance interval is not met.
▶	Rear gear case oil	100h	12M	1000 (1600)	Inspect level. Change yearly if hours or distance interval is not met..
▶	Engine oil / oil filter / oil strainer	100h	12M	1000 (1600)	Inspect for color change. Change if dirty and clean strainer. Change yearly if hours or distance interval is not met.
	Cooling system	50h	6M	500 (800)	Test coolant strength. Pressure test system yearly.

▶ = Severe Use Item. Reduce interval by 50% on vehicles subjected to severe use.

■ = Have an authorized dealer perform repairs that involve this component or system.

● = Emissions related components. Have an authorized dealer perform repairs that involve this component or system.

MAINTENANCE

Item		Periodic Maintenance Intervals (Perform at the interval that arrives first)			
		Hour	Calendar	Miles (km)	Remarks
▶	Radiator	50h	6M	500 (800)	Inspect; clean external surfaces. Clean more frequently if subjected to severe use.
■	Steering system	50h	6M	500 (800)	Inspect. Lubricate.
▶	Front suspension	50h	6M	500 (800)	Lubricate. Check fasteners.
▶	Rear suspension	50h	6M	500 (800)	Lubricate. Check fasteners.
▶	Gear shift	50h	1M	500 (800)	Inspect, lubricate, adjust as necessary.
▶ ■	Throttle body / throttle cable	50h	6M	500 (800)	Inspect. Clean carbon deposits. Inspect cable and lubricate frequently if subjected to severe use.

▶ = Severe Use Item. Reduce interval by 50% on vehicles subjected to severe use.

■ = Have an authorized dealer perform repairs that involve this component or system.

● = Emissions related components. Have an authorized dealer perform repairs that involve this component or system.

MAINTENANCE

Item		Periodic Maintenance Intervals (Perform at the interval that arrives first)			
		Hour	Calendar	Miles (km)	Remarks
▶ ■	CVT drive belt	100h	12M	1000 (1600)	Inspect. Replace as necessary. See dealer for service.
■	CVT drive and driven pulleys	100h	12M	1000 (1600)	Clean and Inspect pulleys. Replace worn parts. See dealer for service.
	Fuel filter and hoses	100h	24M	2000 (3200)	Inspect routing and condition. Replace filter and high-pressure hoses every 4 years.
	Cooling hoses	100h	-	1000 (1600)	Inspect routing and condition.
▶	Valve clearance	100h	-	2000 (3200)	Inspect and adjust as necessary. See dealer for service.

▶ = Severe Use Item. Reduce interval by 50% on vehicles subjected to severe use.

■ = Have an authorized dealer perform repairs that involve this component or system.

● = Emissions related components. Have an authorized dealer perform repairs that involve this component or system.

MAINTENANCE

Item		Periodic Maintenance Intervals (Perform at the interval that arrives first)			
		Hour	Calendar	Miles (km)	Remarks
●	Fuel system	100h	12M	500 (800)	Inspect fuel tank, cap, fuel pump and fuel pump relay.
	Spark plug	100h	24M	2000 (3200)	Inspect; Replace if worn or fouled.
■	Engine mounts	100h	12M	1500 (2400)	Inspect condition.
	Exhaust pipe and spark arrestor	100h	12M	500 (800)	Inspect. Clean spark arrestor.
▶	Wiring, fuses, connectors, relays, and cables	100h	12M	1000 (1600)	Inspect wire routing for wear, security. Apply dielectric grease as necessary to connectors subjected to water, mud, etc.

▶ = Severe Use Item. Reduce interval by 50% on vehicles subjected to severe use.

■ = Have an authorized dealer perform repairs that involve this component or system.

● = Emissions related components. Have an authorized dealer perform repairs that involve this component or system.

MAINTENANCE

Item		Periodic Maintenance Intervals (Perform at the interval that arrives first)			
		Hour	Calendar	Miles (km)	Remarks
▶ ■	Wheel bearings	100h	12M	1500 (2400)	Inspect for noise or looseness. Replace as necessary.
▶	Safety Belts	100h	12M	2000 (3200)	Visually inspect belts and test latches. Clean latch mechanism more often if used in severe conditions. Replace as necessary.
▶	Transmission oil	200h	12M	2000 (3200)	Inspect level. Change yearly if hours or distance interval is not met.
	Coolant	200h	24M	4000 (6400)	Change coolant every 2 years if hours or distance interval is not met.

▶ = Severe Use Item. Reduce interval by 50% on vehicles subjected to severe use.

■ = Have an authorized dealer perform repairs that involve this component or system.

● = Emissions related components. Have an authorized dealer perform repairs that involve this component or system.

MAINTENANCE

Item		Periodic Maintenance Intervals (Perform at the interval that arrives first)			
		Hour	Calendar	Miles (km)	Remarks
▶	Brake fluid	200h	24M	1000 (1600)	Inspect fluid for color change. Change fluid every two years.
	Idle condition	-	12M	-	Inspect for proper rpm. See dealer for service if out of spec or erratic.
■	Steering / Wheel Alignment	-	12M	-	Inspect steering system. See dealer for service whenever steering parts or wheel alignment are required.
▶	Foot brake height	-	12M	-	Inspect. Replace brake pads or adjust height as required.

▶ = Severe Use Item. Reduce interval by 50% on vehicles subjected to severe use.

■ = Have an authorized dealer perform repairs that involve this component or system.

● = Emissions related components. Have an authorized dealer perform repairs that involve this component or system.

MAINTENANCE

Maintenance Procedures

Air Filter

Check and change the air filter at the intervals outlined in the Maintenance Schedule. The air filter element should be cleaned or replaced more often if the vehicle is used in extremely dusty or wet areas. Each time air filter maintenance is performed, check the air inlet of the air filter box for obstructions and debris. Check the air filter housing rubber joint to the throttle body and manifold fittings for an airtight seal. Check that all fittings are secure to avoid the possibility of unfiltered air entering the engine.

Air Filter Housing Inspection

There is a check hose at the bottom of the air filter housing. If dust or water can be viewed in this hose, empty the hose and clean the air filter housing thoroughly.

NOTE:

If a large amount of water is present in the air filter, have your dealer check for water entering the engine crankcase.

MAINTENANCE

Air Filter Maintenance

1. Lift the rear cargo box.
2. Remove the six clasps and remove the air filter cover (1).
3. Remove the four screws and the sponge filter element (2).
4. Inspect the sponge filter element (2) and confirm it could be reinstalled, clean it if necessary. Replace with new filter element (2) if necessary.
5. Remove paper filter element (3).
6. Inspect the paper filter element (3) if could be reused. Brush the dust gently if necessary. Replace with a new filter element (3) if necessary.

NOTE:
Never attempt to wash the filter.

7. When reinstalling the air filter, inspect the sealing ring for dirt, oil or water deposits, and wipe with clean cloth.
8. Apply a layer of lubricating oil on the inner diameter of air filter rubber sealing ring, and install the filter element.
9. Install air filter cover (1), verify proper installation and proper sealing.

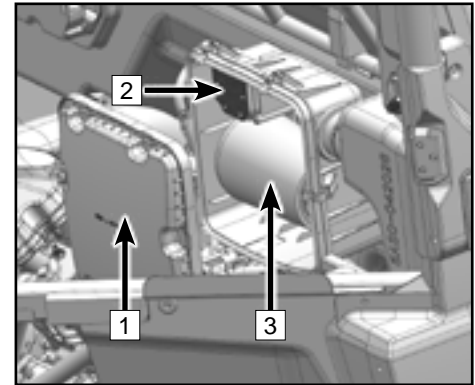

MAINTENANCE

Drying the Air Filter Housing after Submersion

If water has been ingested into the air filter housing, Drain the air filter housing, remove the air filter, and thoroughly dry the components. Do not use compressed air on the paper air filter. Contact your dealer if vehicle performance issues exist.

 **CAUTION**

Do not operate the engine without an air filter element. Unfiltered air entering into the engine can cause engine wear and damage. Driving without an air filter will also decrease performance and can lead to engine overheating.

 **CAUTION**

Major engine damage can result in the vehicle if water has been ingested into the air filter housing, and engine. Have the vehicle serviced by your dealer promptly if your vehicle becomes immersed or stalls in water that exceeds the footrest level. It is important to contact your dealer for service before starting the engine, as water may have been ingested in the air box and engine.

MAINTENANCE

Engine Air Intake Deflector

1. Remove the right access cover (1).
2. The filter element (2) behind the engine air intake deflector is visible.
3. Take out the filter element (2), inspect and check if it can be reinstalled. Clean the filter element (2) if necessary, or install with new filter element if necessary

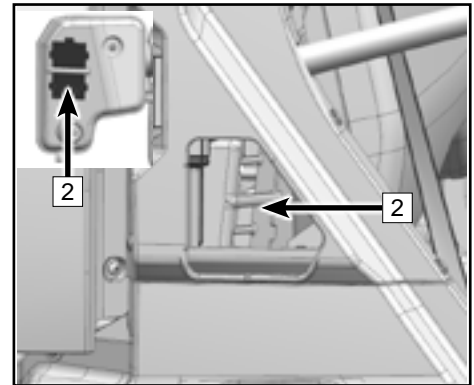
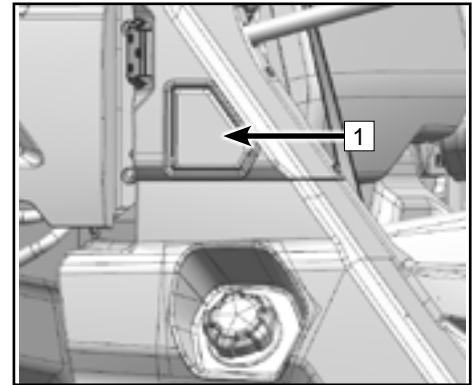

MAINTENANCE

Inspect The Engine Oil Level

Always inspect and change the engine oil at the intervals outlined in the Maintenance Schedule.

1. Place vehicle on level ground with transmission in park.
2. Start the engine and idle for 30 seconds, then stop the engine.
3. Wait for a few minutes to allow the engine oil to settle down inside the engine.
4. Remove passenger seat and the storage box (1) under the seat.
5. Remove the oil dipstick (2) and clean it.
6. Insert the oil dipstick into the dipstick hole (do not fully reinstall it).
7. Remove the oil dipstick and verify the oil level is between upper and lower mark. Maintain the oil level as necessary.
8. Reinstall the oil dipstick and tighten it. Reinstall the storage box and passenger seat.

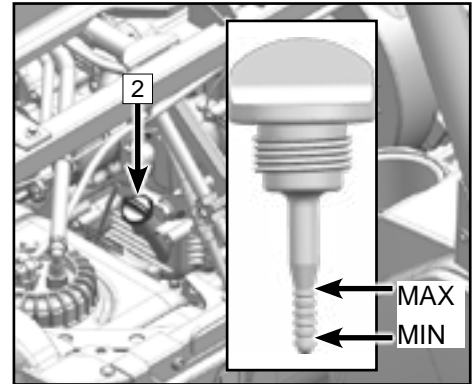
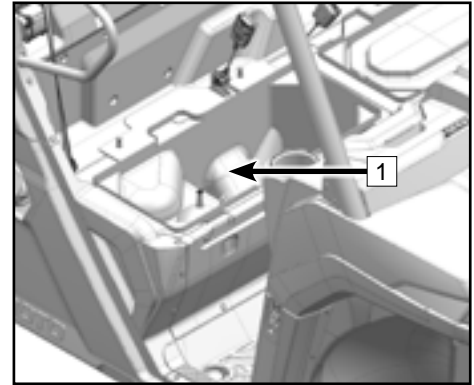

MAINTENANCE

Change the Engine Oil

1. Place vehicle on level ground with the transmission in park.
2. Start the engine and warm for (2~3) minutes, then stop the engine.
3. Place a pan under the engine oil drain hole **1** to collect the used engine oil.
4. Remove the dipstick and wipe it clean.
5. Remove the magnetic drain bolt and washer **2** to drain out the oil.
6. Confirm the engine oil is drained completely.
7. Remove the three bolts **3** on the oil filter cover.
8. Remove the oil filter cover **4**.
9. Inspect the O-ring **6** in the cover, to ensure it is in good condition. Replace with a new one if damaged.
10. Mount O-ring **6** into the oil filter cover, and apply a layer of fresh engine oil for lubricating.
11. Install a new oil filter **5**.
12. Mount oil filter cover **4**, then install and tighten the cover bolts to the specified torque.

Oil Filter Cover Bolt Torque: 7.3 ft-lb.(10N·m)

13. Clean any debris or contaminants from the magnetic drain bolt **2**. Replace the washer with new one if damaged.
14. Install the magnetic drain bolt and washer **2**.

Drain Bolt Torque: 18.5 ft-lb. (25 N·m)

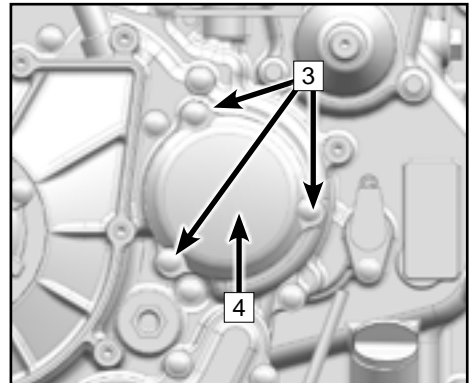
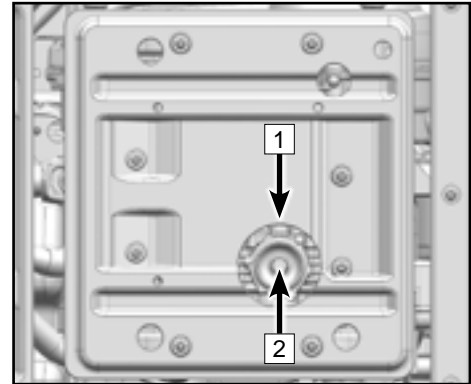

MAINTENANCE

15. Use a dry and clean cloth to wipe the area around magnetic drain bolt.
16. (Filling option 1) Add the recommended type of oil into oil dipstick hole using the funnel, funnel extension tube and tube adapter that are supplied in the tool kit with the vehicle. Keep oil level in the specified range. Remove the funnel assy.
17. (Filling option 2) Open the filling cap on the cylinder head, fill with the recommended type of oil into the oil filling hole. Keep oil level in the specified range.
18. Remove the funnel assy, verify the oil level is between the upper and lower mark with the dipstick, and adjust the oil level accordingly.

CAUTION

Too much or too little oil will have an impact on the normal operation of the engine. Make sure the oil is maintained between the upper and lower marks of the dipstick.

19. Install and tighten the oil dipstick.
20. Verify the vehicle is in parking state, then start and idle the vehicle for 30 seconds.
21. Inspect the engine for leaks after turning off engine. Contact your dealer if leaks are found.

WARNING

When change the engine oil, turn off the vehicle and keep it in parking position to avoid any injury or death.

22. Dispose the used oil and filter in a proper way.

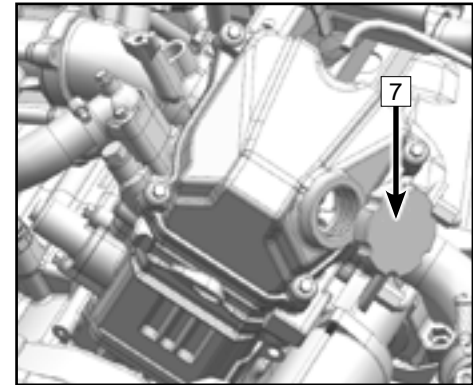
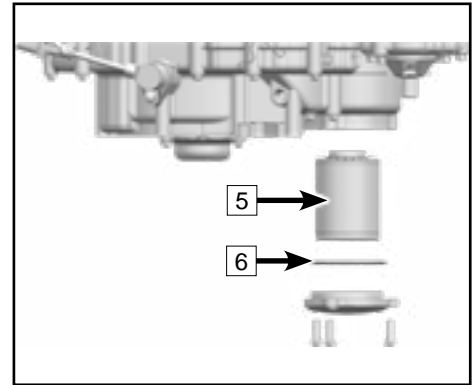

MAINTENANCE

Engine Valve Clearance Adjustment

The intake and exhaust valve clearances change with use of the vehicle, which can result in improper fuel/air supply or engine noise. To prevent this, the valve clearances must be adjusted according to the maintenance schedule. This adjustment should be performed by a professional service technician. Contact your dealer for service.

NOTE:

Intake valve clearance (cold engine): **0.0024 in ~ 0.0055 in. (0.06mm ~ 0.14mm)**

Exhaust valve clearance (cold engine): **0.0043 in ~ 0.0075 in. (0.11mm ~ 0.19mm)**

Engine Idle Speed

This vehicle is equipped with an electronic fuel injection system. The throttle body is a vital part of the fuel system which requires very sophisticated adjustment, and was set at the factory. There are no consumer provisions to adjust engine idle speed. If the settings are disturbed, poor engine performance and damage may result. Check the engine idle speed for stability or an abnormal engine idle condition and contact your dealer for service if necessary.

MAINTENANCE

Front and Rear Gear Case

Inspect the front and rear gear case for any leaks before operating the vehicle, if found any leaks, stop operating the vehicle and contact with your dealer for inspection and service.

Change the Front and Rear Gear Case Oil

1. Place vehicle on level ground with the transmission in park.
2. Place an oil pan under the gear case to collect the used oil.
3. Remove the magnetic drain bolt and washer at the bottom of gear case.
4. Clean any debris or contaminants from the magnetic drain bolt. Replace the washer with new one if damaged.
5. Wait for several minutes until the gear case is completely drained.
6. Install magnetic drain bolt and washer.

Drain Bolt Torque : 18.4 ft-lb. (25 N·m)

7. Remove filling bolt and washer (3).
8. Add the recommended type of oil (SAE 80W-90 GL-5) by specified volume using the funnel, funnel extension tube and tube adapter that are supplied with the vehicle.

Front gear case oil volume: 8.45 oz. (250 mL)

Rear gear case oil volume: 13.5 oz. (400 mL)

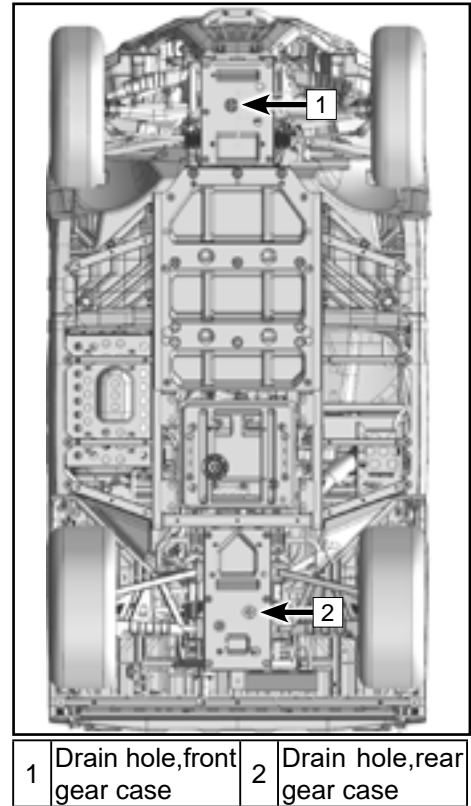

MAINTENANCE

9. Mount the filling bolt and washer (3).

Torque for filling bolt: 18.4 ft-lb. (25 N·m)

10. Dispose the used oil in a proper way.

11. The oil replacement method is the same for both front and rear gear cases.

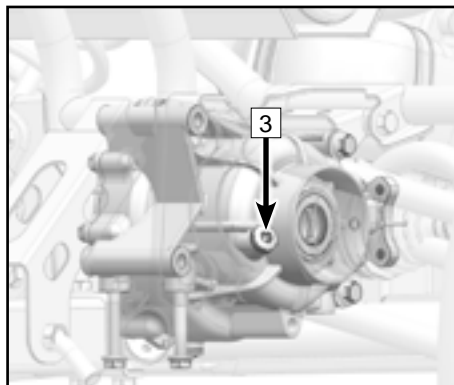
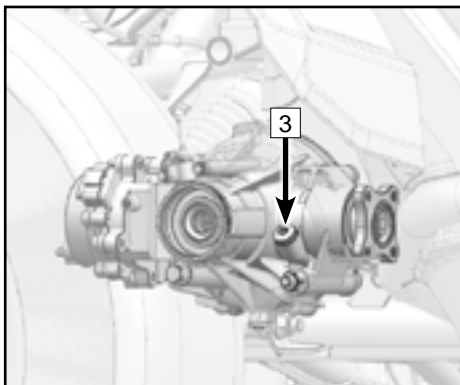

MAINTENANCE

Front and Rear Axle Boots

The front and rear axle boots (1) must be checked for holes or wear before operating. If any damage is found, have your dealer repair the vehicle.

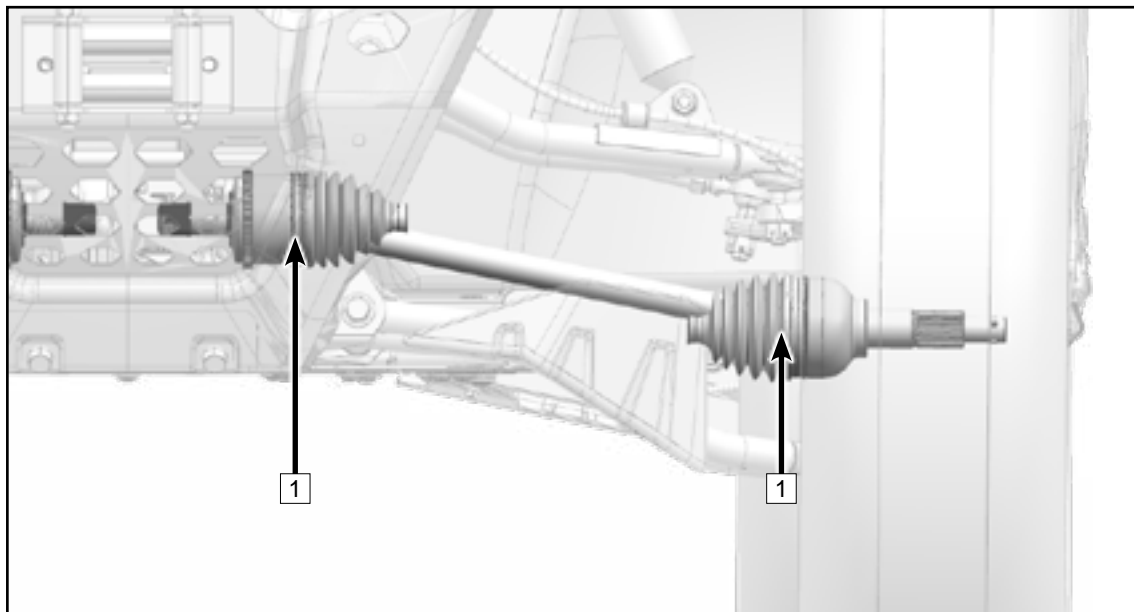

MAINTENANCE

What to do if water collects in the CVT housing

If the vehicle was submerged in water deep enough that water has entered the CVT housing, remove the drain bolt (1) at the bottom of the housing to drain the water from the case.

Water drain bolt torque: 18.4 ft-lb.(25 N•m)

CAUTION

If water drains from the CVT housing after removing the bolt, have your dealer inspect the vehicle, as water may have affected the CVT system and other engine parts.

Drying a Wet CVT System

If the CVT system was submerged and the drive belt is slipping, any remaining moisture inside the CVT housing after draining can be expelled by running the engine above 2000 RPM in Park or Neutral for (30~60) seconds, then testing for proper CVT function in low gear. Repeat as necessary. If the CVT system continues to slip or have poor performance, contact your dealer.

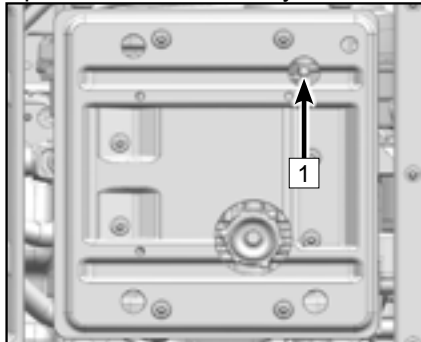

MAINTENANCE

Cooling System

Inspect coolant level

1. Place vehicle on level ground with the transmission in park.
2. Wait for the engine cooling down to ambient temperature, then inspect the coolant level.
3. Release the LH & RH hood clasps, then turn up the hood.
4. Verify coolant level is between upper and lower marks at the side of the coolant reservoir (1).
5. Reinstall the front hood.

CAUTION

If coolant level is increased, contact your dealer to inspect the antifreeze content of the coolant as soon as possible.

Distilled water can be used for short time if coolant is not available, softened tap water could be the second choice. Never add hard water or salt water, as it is harmful to the engine.

The radiator fan operation is automatically switched on or off according to the coolant temperature during operation.

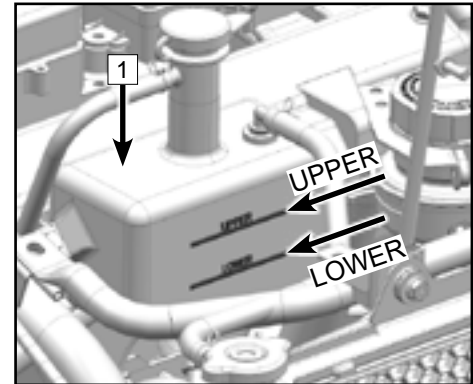
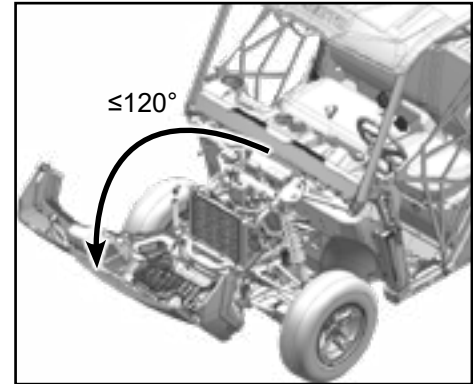

MAINTENANCE

Change the Coolant

WARNING

Never remove the radiator cap if the engine is hot. Wait for the engine to cool down before removing the radiator cap. Hot coolant can cause serious burns.

1. Place vehicle on level ground with the transmission in park.
2. Wait for the engine cooling down to ambient temperature, then inspect the coolant level.
3. Release the LH & RH hood clasps, then turn up the hood.
4. Remove radiator cap (1) and coolant reservoir cap (2).
5. Place a container under the front of engine coolant drain bolt (3), then remove the drain bolt and washer.
6. Wait until coolant has drained completely, then install the coolant drain bolt and washer. Replace with new one if washer is damaged. Do not fully tighten the drain bolt at this time.
7. Remove the coolant reservoir hose and allow it to drain completely, then install the coolant reservoir hose.
8. Fill coolant into the radiator using the funnel supplied with the vehicle. **NOTE:** The funnel should be cleaned completely of any oil or other substance that may contaminate the coolant.

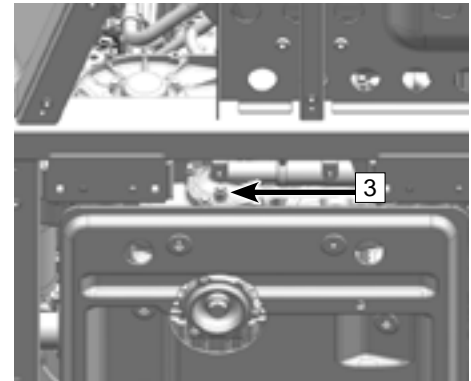
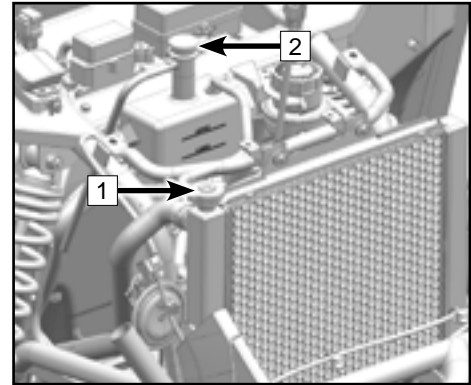

MAINTENANCE

9. During filling coolant, unscrew the coolant drain bolt to release residual air inside the coolant hose until only fluid flows out, then screw back in and tighten the drain bolt.

Drain Bolt Torque: 7.4 ft-lb. (10 N·m)

10. Install radiator cap after filling the coolant.
11. Start the engine and idle for several minutes until the cooling fan turns on, then turn off the engine.
12. Inspect the coolant level after engine cool-down. Add additional coolant into the top of radiator if coolant level is low.
13. Fill coolant into reservoir until the level is between the upper and lower mark.
14. Install coolant reservoir cap.
15. Start the engine and idle for several minutes to inspect for leaks, contact your dealer to inspect the cooling system if any leaks are found.
16. Close the hood and secure the LH & RH hood clasps.
17. Dispose the used coolant in a proper way.

MAINTENANCE

Recommended antifreeze:

Any high quality ethylene glycol antifreeze containing corrosion inhibitors for aluminum engines. CFMOTO recommended coolant freeze protection level: -35°C.

Antifreeze and distilled water mixing ratio: **1:1**

Total coolant capacity (without reservoir capacity): **3.8 qt. (3.6 L)**

Coolant changing capacity (without reservoir capacity): **3.7 qt. (3.5 L)**

Reservoir capacity: 0.32 qt (0.3 L) ~ 0.62 qt (0.59 L)

Lower mark: 0.32 qt (0.3L); Upper mark: 0.62 qt (0.59 L)

Cleaning the Radiator

Cleaning the external surfaces of the radiator if it is covered with mud or debris will ensure it continues to efficiently cool the engine. Use only low pressure water to clean the radiator. High pressure washers can damage components. Ensure that water can flow freely through the radiator fins. This is a sign that cooling air will be allowed to pass through.

WARNING

If replace with different coolant, please contact with your dealer to drain out completely the residual coolant. Different coolant mixture may lead to engine failure.

MAINTENANCE

Spark Plug(s)

The spark plug (1) is an important engine component that is easy to inspect. The color and condition of the spark plug can indicate the condition of the engine. The ideal color on the insulator around the center electrode is a medium-to-light tan color for an engine that is being operated normally. If electrode erosion becomes excessive, or if carbon and other deposits are excessive, you should replace the spark plug with the specified plug.

Periodically remove and inspect the spark plug(s) for heat damage and deposits that will cause them to break down and erode. Do not attempt to diagnose spark plug color or engine problems yourself. Instead, take the vehicle to your dealer for service.

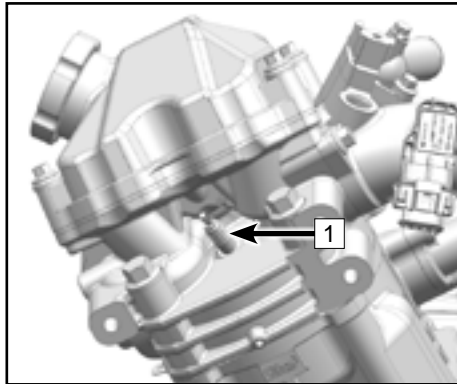

MAINTENANCE

Spark Plug Removal and Inspection

1. Place vehicle on level ground with transmission in park.
2. Lift the rear cargo box.
3. Remove the spark plug cap.(Spark plug is located under the rear cargo box on the engine magneto side.)
4. Use the spark plug socket and wrench from the tool kit to remove the spark plug.
5. Check the spark plug gap (A) using a thickness gauge. Adjust the gap if necessary.

NOTE:

Specified spark plug: **DCPR8E (NGK)**

Spark plug gap: **0.031 in ~ 0.035 in (0.8 mm ~ 0.9 mm)**

6. Clean the gasket surface. Wipe off any grime from the threads.
7. Install spark plug and tighten to specified torque.

Spark Plug Torque: 14.8 ft-lb. (20 N•m).

NOTE: If a torque wrench is not available when you are installing a spark plug, a good estimation of the correct torque is to tighten the spark plug by finger first, then use tool to tighten 1/4 to 1/2 turn.

8. Install the spark plug cap.

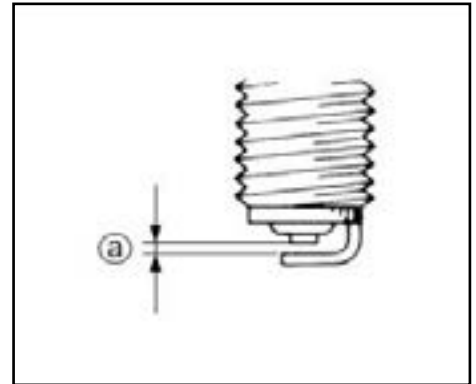

MAINTENANCE

Spark Plug Removal to Expel Water from the Engine

If water has been ingested into the engine, it is important to remove the water as soon as possible by removing the spark plug(s) and using the starter system to rotate the engine for a short period to expel water out of the cylinder(s). Verify that the air box has been drained of water before attempting to expel water. Have a dealer service the engine immediately.

CAUTION

Major engine damage can result in the vehicle if water is ingested into the engine. Have the vehicle serviced by your dealer promptly if your vehicle becomes immersed or stalls in water that exceeds the footrest level. It is important to contact your dealer for service before starting the engine if water has been ingested. Water inside the engine can cause a 'hydraulic lock' effect that can damage the starter and engine components. The engine oil should be checked for water contamination. Drain and refill with new engine oil if water is found in the crankcase.

MAINTENANCE

Exhaust Pipe Spark Plug Arrestor

Clean the carbon deposits from the spark arrester periodically. Blocked spark arrester will decrease the engine power. After driving through mud or water, inspect the spark arrester and clean it if necessary.

WARNING

The exhaust system temperature is very high just after operation. Touching the pipe may lead to serious injury. Make sure the exhaust system is cooled, and then proceed with inspection and cleaning.

Remove the cap nuts and washers (1).

Remove spark arrester (2).

Use a steel brush to clean any carbon deposits from the steel screen (3) of the spark arrester.

Clean inside the spark arrester with compressed air.

Inspect for damage or wear to the steel screen of the spark arrester. Replace with a new spark arrester if damaged or worn.

Reinstall the spark arrester, washers and cap nuts onto the muffler. Torque: **7.4 ft-lb. (10 N•m)**.

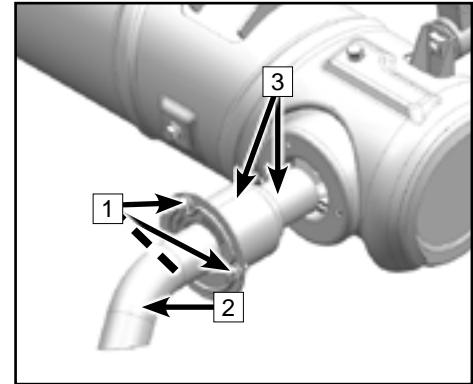

MAINTENANCE

Battery

This vehicle is equipped with a 12 volt / 30 Amp-hour, sealed low maintenance battery (A). Therefore, it is not necessary to check the electrolyte or add distilled water into the battery. If the battery seems to be discharged, cover is damaged, or other problem exists, contact your dealer. The battery is located on the lower frame area between the driver seat and cargo box.

CAUTION
Do not operate electrical system lighting or accessories for long periods without the engine running to charge the battery. The battery may discharge to a point that the starter motor will not operate properly. If this should happen, please remove the battery and charge it.

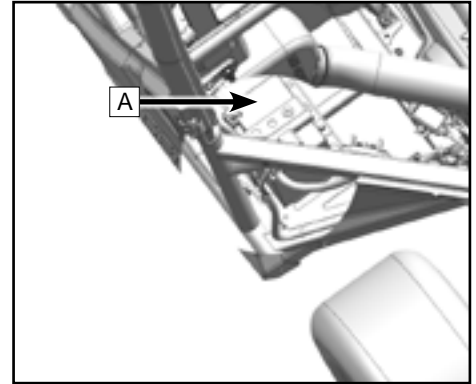

MAINTENANCE

Battery Removal

Place vehicle on level ground with the transmission in park.

Turn off the stop switch, turn the key to the OFF position, make sure the ignition system is in power off condition for the vehicle.

Lift up the rear cargo box.

Remove the black negative wire (-).

Remove the red positive wire (+).

Remove the battery belt.

Take out the battery.

Battery maintenance

Apply a mixture of baking soda and water with a soft brush to clean the battery top and terminals.

Clean away dirt and any corrosion on positive and negative wire terminals with a stiff brush.

A special battery charger (constant low voltage / ampere) is required for recharging low-maintenance batteries. Using a conventional battery charger may shorten the battery life.

If the vehicle will not be used for a month or longer, take out the battery and store it in a cool, dry place. Completely recharge the battery before re-installation. When charging the battery, it should be taken out from the vehicle.

MAINTENANCE

Battery Installation

Place vehicle on level ground with the transmission in park.

Turn off the stop switch, turn the key to the OFF position, make sure the ignition system is in power off condition for the vehicle.

Put the battery in place.

Install the battery fixing bracket.

Install the red positive wire (+).

Install the black negative wire (-).

WARNING

Avoid contact with skin, eyes or clothing, and always shield eyes when working near batteries. Keep out of reach of children. Keep batteries away from sparks, flames, cigarettes or other sources of ignition. Ventilate the area when charging or using in a closed space.

Battery acid antidote:

EXTERNAL: Flush with water.

INTERNAL: Get prompt medical attention.

EYES: Flush with water for 15 minutes and get prompt medical attention.

NOTE: Wrong operating sequence for positive and negative wires installation or disassembly may lead to short circuit between battery and the vehicle.

MAINTENANCE

Battery Charging

Remove battery.

Connect the charger with the positive and negative end of battery.

Switch on the charger.

NOTE: It's recommended to charge the battery with current 10% of the battery amp-hour capacity.

Disconnect the charger after finishing charging.

Separate the charger and battery.

NOTE: If the vehicle will not be used for a long time, the battery should be recharged every month.

MAINTENANCE

Brakes

Brake Fluid Level Inspection

Before riding, check that the brake fluid level is above the low mark and replenish whenever necessary. The brake fluid reservoir is located under the front access cover. Insufficient brake fluid may let air enter the brake system, possibly causing the brakes to become ineffective.

Observe these Precautions:

- When checking the fluid level, make sure the vehicle is on a level surface.
- Use only the designated quality brake fluid. Otherwise, the rubber seals may deteriorate, causing leaks and poor brake performance.
- Recommended brake fluid: DOT 4.
- Refill with the same type of brake fluid. Mixing fluids may result in a harmful chemical reaction and may lead to poor brake performance.
- Be careful that water does not enter the master cylinder reservoir. Water will significantly lower the boiling point of the fluid and lead to poor brake performance.
- Brake fluid may deteriorate painted surfaces or plastic parts. Always clean up spilled fluid immediately.
- As the brake pads wear, it is normal for the brake fluid

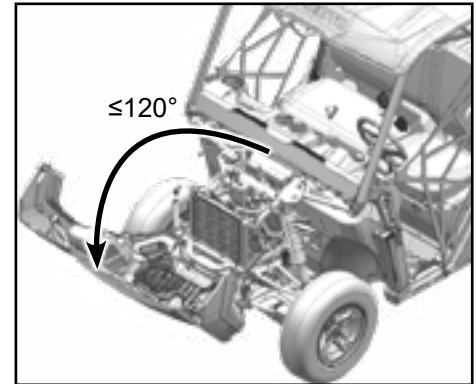

MAINTENANCE

level to gradually go down. A low brake fluid level may indicate worn brake pads or brake system leakage. Therefore, be sure to check the brake pads for wear before checking the brake system for leakage.

- Have your dealer check the cause if the brake fluid level goes down unexpectedly.

Brake Pad Inspection

Inspect the front and rear brake pads and discs for damage and wear. If the pad thickness² is less than 0.08 in. (2.0 mm) or the disc thickness¹ is less than 0.16 in. (4.0 mm), have your dealer replace them. Replacement of brake components requires professional knowledge, and should be performed by your dealer.

NOTE:

Wheels must be removed to check brake pads.

CAUTION

After servicing:

- Make sure the brakes operate smoothly and that the lever free play is correct.
- Make sure the brakes do not drag and the brake operation is not spongy.
- All air is bled from the brake system.

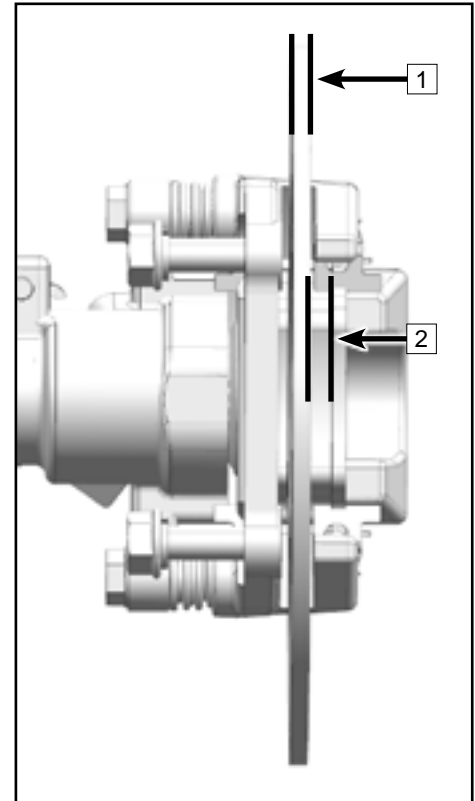

MAINTENANCE

Brake Fluid Change

Complete brake system fluid replacement should be performed only by trained service personnel. Have your dealer replace the following components during periodic maintenance, or when they are damaged or leaking:

- Replace the brake hoses every four (4) years.

WARNING

An over-full master cylinder may cause brake drag or brake lockup, which could result in an accident causing serious injury or death. Maintain brake fluid at the recommended level. Do not overfill.

WARNING

Never store or use a partial bottle of brake fluid. Brake fluid is hygroscopic, meaning it rapidly absorbs moisture from the air. The moisture causes the drop of boiling temperature of the brake fluid, which can lead to early brake fade and the possibility of accident or severe injury. After opening a bottle of brake fluid, always discard any unused portion.

Brake Light Operation

The brake light is activated by foot brake pedal pressure, and is properly working when the brake light comes on just as braking takes effect. Check that the switch assembly or the electrical circuit is working properly in case of brake light failure.

Suspension

Some front suspension components of the vehicle do not require maintenance or lubrication. Ensure these components are cleaned regularly, and are not loose or damaged before operating the vehicle.

MAINTENANCE

Suspension Lubricating and Adjustment

Lubricate the front and rear swing arm bushing, and rear stabilizer bar.

Add lubricating grease into grease nipple (1) with a grease gun until it begins to flow from bushing.

NOTE:

There are 4 grease nipples on front swing arms, and 6 grease nipples on the rear swing arms, and 2 grease nipples on the rear stabilizer bar, they are symmetrical in left and right.

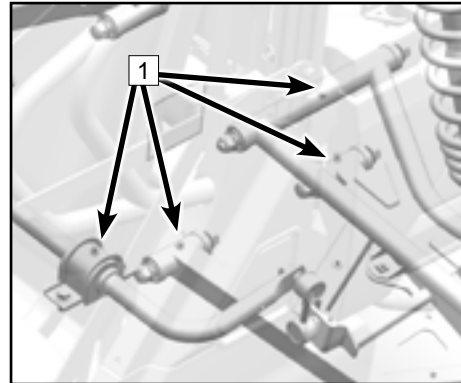
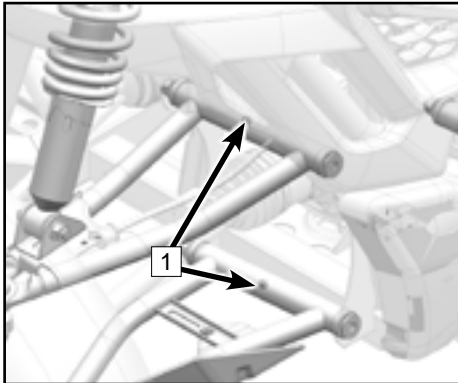

MAINTENANCE

Shock Absorber Adjustment

When riding on rough terrain conditions, using the hitch to tow, or carrying the maximum weight of people and cargo, increase the spring preload to get firmer riding. Decrease the spring preload as necessary for rough or soft terrain, to get smooth riding.

Proper spring preload setting is a personal preference, and changes with rider weight, riding style and conditions.

NOTE: Elevating the vehicle with the tires off the ground assists with adjustments.

Increase spring preload:

Turn adjuster **1** in direction **a** with special tool **2** from the kit.

Decrease spring preload:

Turn adjuster **1** in direction **b** with special tool **2** from the kit.

NOTE:
Wrenches are included in the tool kit for adjusting shock absorber spring preload. If not, please contact your dealer to make adjustment.

Standard preload position: B

A: Minmum (soft)

B: Maxmum (Hard)

NOTE: Keep the left and right preload with the same setting.

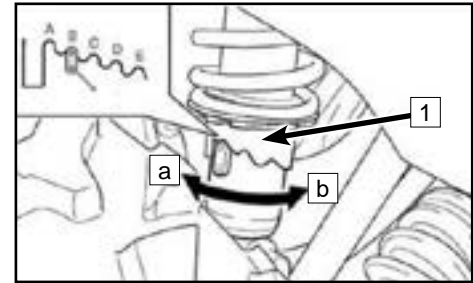

MAINTENANCE

Wheels

Tire Pressure

Before operating the vehicle, use tire pressure pen to inspect the tire pressure:

Front tire:

When the load is less than 195 kgs: 10 PSI (70 kPa)

When the load is more than 195 kgs: 11 PSI (80 kPa)

Rear tire:

When the load is less than 195 kgs: 14 PSI (100 kPa)

When the load is more than 195 kgs: 17 PSI (120 kPa)

Tread Depth

Inspect the tread depth regularly and replace the tires if the minimum tread depth is less than:

Minimum tread depth: **3/32 in. (3.0 mm)**

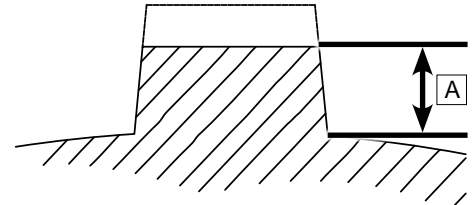
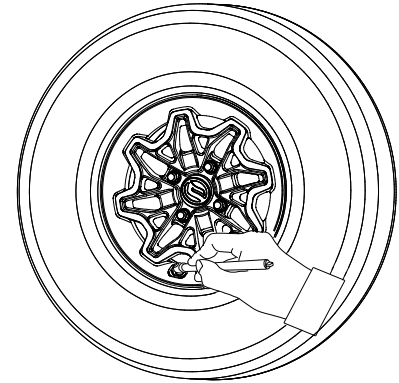

Wheel Bearings

- Lift the vehicle and support it securely under the frame with the tires off the ground.
- Push and pull the wheels at the outer edges to feel for side play or looseness. See your dealer if there is any side play or looseness.

MAINTENANCE

Change the Wheel

Disassembling

1. Place vehicle on level ground.
2. Lift the vehicle and support the vehicle securely under the frame using a jack or other suitable tool so the wheel is off the ground.
3. Remove the hexagon slotted wheel nut (1).
4. Remove wheels.

Installation

1. Install the wheels onto the wheel hub and secure with wheel nuts.
2. Torque the wheel nuts to specification.

Wheel Nut Torque: 52 ~ 59 ft-lb. (70 ~ 80 N·m)

3. Remove the vehicle support and place vehicle on the ground.

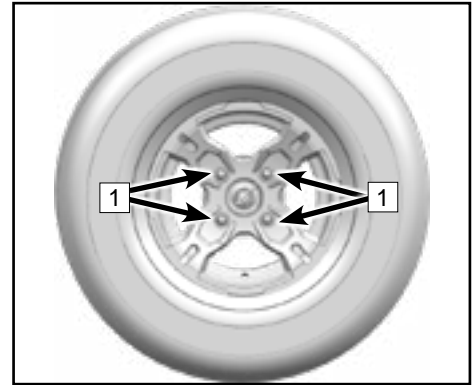

MAINTENANCE

Electrical

Fuse Box







The fuse box is located under the front hood. If a fuse is blown, turn off the main switch, install a new fuse with specified amperage. Turn on the main switch. If fuse blows again immediately, contact your dealer.

Electronic relays mounted in the fuse box operate all system functions of the vehicle. If a relay fails to operate or replacement or diagnostic of a relay is required, please contact your dealer.







CAUTION

To prevent an accidental short-circuit, turn off the main switch before checking or replacing fuses. Always use a fuse with the correct specified rating. Never use conductive material in place of the proper fuse. Using an improper fuse can cause damage to the electrical system and may lead to a fire.

For LED light

MAIN RELAY	AUXILIARY START RELAY	MAIN DRIVING HEATING RELAY	COPILOT HEATING RELAY	FAN RELAY	FUEL PUMP RELAY	2-4 RELAY
						4-4 RELAY
FUEL PUMP 10A	SIGNAL A 15A	BACKUP 15A	HMI 10A		REVERSE RELAY	
HEADLIGHT 15A	EFI 15A	FAN 15A	SIGNAL B 15A			

For halogen light

MAIN RELAY	AUXILIARY START RELAY	MAIN DRIVING HEATING RELAY	COPILOT HEATING RELAY	FAN RELAY	FUEL PUMP RELAY	2-4 RELAY
						4-4 RELAY
FUEL PUMP 10A	SIGNAL A 15A	BACKUP 15A	HMI 10A	LOW BEAM RELAY	HIGH BEAM RELAY	REVERSE RELAY
HEADLIGHT 15A	EFI 15A	FAN 15A	SIGNAL B 15A			

MAINTENANCE

Main Fuse and EPS Fuse

A 40 Amp main fuse and a 40 Amp EPS (1) fuse are located next to the battery. If the fuse is blown, turn off the main switch and install a new fuse of the specified amperage. Turn on the main switch. If the fuse immediately blows again, please contact your dealer.

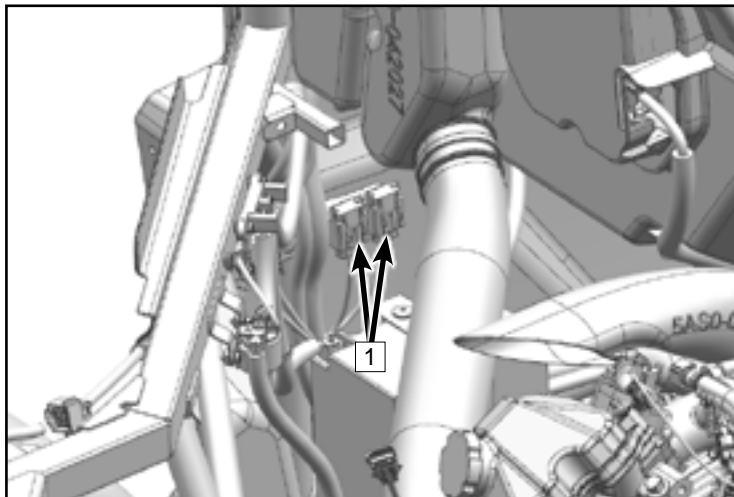

MAINTENANCE

Headlight Adjustment

To adjust the headlight:

Take off the LH & RH clasps and open front hood.

Adjust the adjustment screw (1) to adjust the high beam direction vertically.

Adjust the adjustment screw (2) to adjust low beam direction vertically.

⚠ WARNING

It is advisable to have your dealer perform headlight adjustments. Improper adjustment could lead to an accident resulting in serious injury or death.

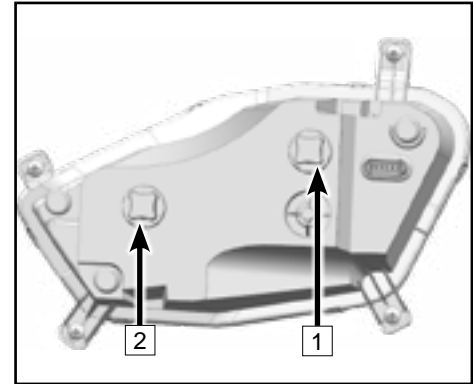

Lamps for the vehicle

For LED lights: LED structure cannot be repaired if damaged or failed, have your dealer replace the entire assembly if an LED is damaged or has failed.

For halogen lights: Please contact your CFMOTO dealer to service or replace the light if any damage or fault.

MAINTENANCE

Safety Belt

This vehicle is equipped with three point safety belts for driver and passenger. Please make sure all safety belts are fastened safely before operating the vehicle.

 **WARNING**

Falling from a moving vehicle will lead to serious injury or death. Always fasten the seat belts before operating or driving the vehicle.

Follow below steps to fasten the safety belts:

- For three point safety belt, pull down the belt lock plug **1**, cross the shoulder, chest and hip without any twist.
- Insert lock plug **1** into the lock catch **2** until it sounds a click.
- Loosen a little the safety belt and let it tension automatically.
- Press the red button to open the safety belt.

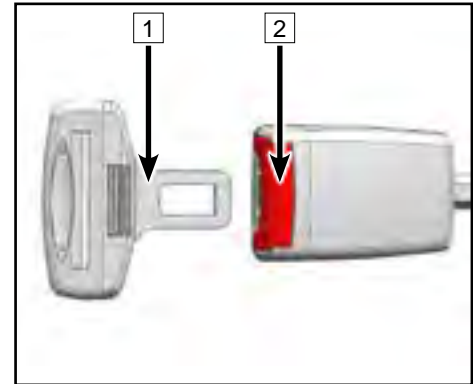

MAINTENANCE

Always inspect all seat belts that can work normally before every operation of the vehicle.

1. Insert the lock plug into the lock catch until it sounds a click. The lock plug can be inserted smoothly. Click sound means it is fastened safely.
2. Press red button to unlock that make sure the safety belts can be unlocked smoothly.
3. Pull out all the safety belts to inspect if any damage for all length of belts, including cut damage, wear damage or stiffening. If found any damage or it can not work normally, please ask your authorized CFMOTO dealer or qualified technician to inspect or replace the whole safety belt system.
4. Clean the dirt on the safety belt, wash the belt with soft soap water, never use bleach, dye or household detergent. Wash the whole length belt. Flush the lock plug **1** and the retractor cover **2** regularly with a garden hose.

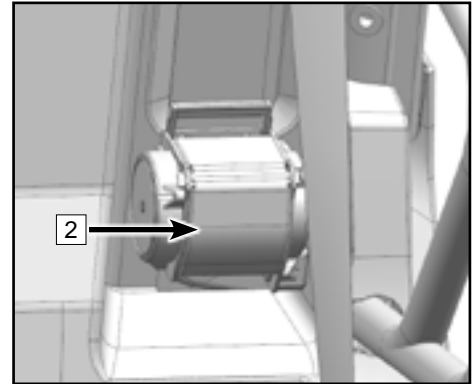
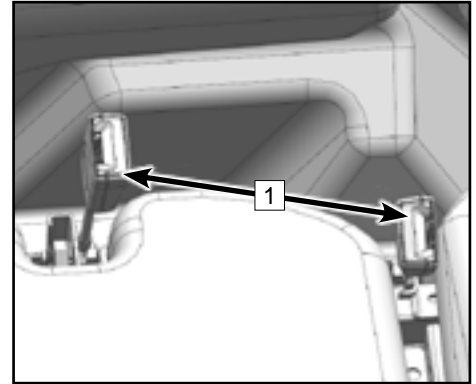

CLEANING AND STORAGE

Cleaning and Storage

Washing the Vehicle

Keeping your vehicle clean will not only improve its appearance, but it can also extend the life of various components. With a few precautions, your vehicle can be cleaned much like an automobile:

- The best and safest way to clean your vehicle is with a garden hose and a pail of mild soap and water. Harsh detergents may deteriorate rubber components.
- Use a professional type washing mitt, cleaning the upper body first and the lower parts last.
- Pay special attention that the cooling system radiator and axle boots are thoroughly cleaned of all dirt and debris.
- Rinse with water frequently and dry the vehicle with a chamois to prevent water spots.
- Lubricate all pivot points immediately after washing.
- Allow the engine to run for a while to evaporate any water that may have entered the engine air intake or exhaust system.

CFMOTO does not recommend the use of a high pressure type car wash system for washing your vehicle, as water can be forced past seals and damage decals. If a high pressure system is used, exercise extreme care to avoid water damage to the decals, wheel bearings, transmission seals, body panels, brakes, warning labels, air filter intake system and electrical system. Ensure water is not allowed to enter into the air filter or CVT housing. If warning and safety labels are damaged, contact your dealer for a replacement.

CLEANING AND STORAGE

Waxing the Vehicle

Your vehicle can be waxed with any non-abrasive automotive paste wax. Avoid the use of harsh cleaners since they can scratch the body finish.

 CAUTION
--

Certain products, including insect repellent and other chemicals, will damage plastic surfaces. Use caution when using these products near plastic surfaces.

Perform Repairs

Make necessary repairs to your vehicle before storing to prevent further damage the next time you operate it.

Check the Tires

Inspect the tire treads and overall condition. Set the tires to the specified air pressure.

Oil and Filter

Warm the engine, then stop the engine and change the oil and filter.

Air Filter/ Air Box

Inspect and clean or replace air filter. Clean the air box and the sediment tube.

CLEANING AND STORAGE

Check Fluid Levels

Inspect the following fluid levels and change if necessary:

- Front gear case
- Rear gear case
- Brake fluid (change every two years or as required if fluid looks dark or contaminated)
- Coolant (change every two years or as required if coolant looks contaminated)
- Fuel Level (add fuel stabilizer according to the product label directions)

Stabilize the Fuel

Fill the fuel tank with fresh fuel that has been treated with fuel stabilizer according to the product label directions. Do not allow untreated fuel to remain in the tank longer than 30 days, as the fuel begins to degrade and can cause damage to the fuel system components.

Battery Storage

- Remove the battery from the vehicle and ensure that it is fully charged before placing it in storage. Protect the battery from freezing temperatures, which can damage the battery.

Lubricate

Inspect all cables and lubricate with cable lubricant according to the product label directions. Grease the vehicle lubricating points with all season grease.

CLEANING AND STORAGE

'Fog' the Engine

- Remove the rear access cover to access the spark plug(s).
- Remove the spark plug(s), rotate the piston to the bottom of its stroke, and pour approximately 2 oz. (15mL ~ 20mL) of engine oil into the opening.

NOTE:

Do this carefully! If you miss the spark plug hole, oil will drain from the spark plug cavity, and appear to be an oil leak. To access the spark plug hole, use a section of clean hose and a small plastic squeeze bottle filled with the pre-measured amount of oil.

- Reinstall the spark plug(s). Torque the spark plug to specification.
- Turn engine over several times slowly. Oil will be forced in and around the piston, piston rings and the cylinder will be coated with a protective film of fresh oil.
- Reinstall the spark plug(s), cap(s), and side panel.

NOTE:

Starting the engine during the storage period will disturb the protective film created by fogging. Corrosion could occur. Never start the engine during the storage period.

Storage Area And Covering

Support the vehicle with stands under the frame with the tires 30 ~ 40mm (1.2 ~ 1.6 in.) off the ground. Be sure the storage area is well ventilated, and cover the machine with an approved cover.

NOTE:

Do not use covers made of plastic or coated materials. They do not allow enough ventilation to prevent condensation, and may promote corrosion and oxidation.

CLEANING AND STORAGE

Transporting the Vehicle

Follow these procedures when transporting the vehicle:

- Turn off the engine and remove the key to prevent loss during transporting.
- Ensure the fuel cap is installed correctly and secure.
- Ensure the seat is installed correctly and secure.
- Place the gear selector into any position except the parking position, and block the front and rear wheels to prevent the vehicle from moving.

 **CAUTION**

Never transport with the gear selector in the parking position.

Damage to the engine and transmission may result.

- Secure both the front and rear of the vehicle frame to the transport to prevent the vehicle from sliding or moving.

VEHICLE ISSUE DIAGNOSIS

Vehicle Issue Diagnosis

This section is intended to guide an average owner to simple items that could cause operating problems. Diagnosis of vehicle issues may require the experience of a dealership technician. Please contact your dealer if a solution is not apparent.

Engine Does not Turn Over

Possible Cause	Solution
Blown fuse	Reset or replace the fuse
Low battery voltage	Recharge battery to 12.8 Vdc – Confirm battery state of health
Loose battery connections	Check all connections and tighten if necessary
Loose starter system electrical connections	Check all connections and tighten if necessary
Engine stop switch	Check function
Start circuit not complete – transmission in gear	Press foot brake or shift transmission to neutral or parking position.

Engine Pings or Knocks

Possible Cause	Solution
Poor quality or low octane fuel	Replace with minimum 89 octane unleaded fuel
Incorrect ignition timing.	See your dealer
Incorrect spark plug gap or heat range	Set spark plug gap to specs or replace plugs

VEHICLE ISSUE DIAGNOSIS

Engine Stops or Loses Power

Possible Cause	Solution
Overheated engine	Clean radiator screen and external core. clean engine exterior. See your dealer
Out of fuel	Refuel with minimum 89 octane unleaded fuel
Kinked or plugged fuel tank vent line	Inspect and replace. See your dealer
Water present in fuel	Replace with new fuel
Fouled or defective spark plugs	Inspect and clean or replace spark plug
Worn or defective spark plug wires	See your dealer
Incorrect spark plug gap or heat range	Set gap to specs or replace plug
Possible Cause	Solution
Loose ignition connections	Check all connections and tighten
Low battery voltage	Recharge battery to 12.8 Vdc; check charging system - Confirm battery health
Clogged air filter	Inspect and replace as necessary
Reverse speed limiter malfunction	See your dealer
Electronic throttle control malfunction	See your dealer
Other mechanical failure	See your dealer

VEHICLE ISSUE DIAGNOSIS

Engine Turns Over, Fails to Start

Possible Cause	Solution
Engine turns over, Fails to start	Refuel
Clogged fuel filter	Inspect and replace as necessary
Water is present in fuel	Replace with 89 minimum octane unleaded fuel
Fuel pump is inoperative	Inspect pump and fuse; Replace as necessary
Old or non-recommended fuel	Replace with 89 minimum octane unleaded fuel
Possible Cause	Solution
Fouled or defective spark plugs	Inspect spark plugs, replace if necessary
No spark to spark plug	Inspect spark plugs, verify stop switch is on
Crankcase filled with water or fuel	Immediately see your dealer
Clogged air filter	Inspect and replace as necessary; Replace spark plugs as necessary
Clogged fuel injector	See your dealer
Low battery voltage	Recharge battery to 12.8 Vdc - Confirm battery health
Mechanical failure	See your dealer

VEHICLE ISSUE DIAGNOSIS

Engine Backfires

Possible Cause	Solution
Weak spark from spark plugs	Inspect and replace spark plugs as necessary
Incorrect spark plug gap or heat range	Set gap to specs or replace plugs
Old or non-recommended fuel	Replace with minimum 89 octane unleaded fuel
Incorrectly installed spark plug wires	See your dealer
Incorrect ignition timing	See your dealer
Mechanical failure	See your dealer
Speed limiter malfunction	See your dealer

Engine turns over, Fails to start

Possible Cause	Solution
Fouled or defective spark plugs	Inspect and replace spark plugs as necessary
Worn or defective spark plug wires	See your dealer
Incorrect spark plug gap or heat range	Set gap to specs or replace plugs
Loose electrical connections	Check all connections and tighten
Water present in fuel	Replace with new fuel
Low battery voltage	Recharge battery to 12.8 Vdc; Check charging system
Kinked or plugged fuel tank vent line	Inspect and replace
Incorrect fuel	Replace with 89 minimum octane unleaded fuel
Clogged air filter	Inspect and replace as necessary; Replace spark plugs as necessary

VEHICLE ISSUE DIAGNOSIS

Possible Cause	Solution
Reverse speed limiter malfunction	See your dealer
Electronic throttle control malfunction	See your dealer
Other mechanical failure	See your dealer
Possible Lean or Rich fuel mixture	See your dealer
Low or contaminated fuel	Add or change fuel, clean the fuel system
Low octane fuel	Replace with minimum 89 octane unleaded fuel
Clogged fuel filter	Replace filter
Fuel is very high octane	Replace with minimum 89 octane unleaded fuel

VEHICLE ISSUE DIAGNOSIS

EFI Malfunction Indicator Light

The Electronic Fuel Injection system on your vehicle contains a self-diagnostic feature that will illuminate the malfunction indicator light (MIL) if it detects a problem. When this indicator flashes, please contact your dealer. During normal operation, the EFI indicator will be off.

The fault code will display on the dashboard directly, record the fault code and contact your dealer for diagnosing. Your dealer has the EFI tool required to diagnose, repair and clear trouble codes.

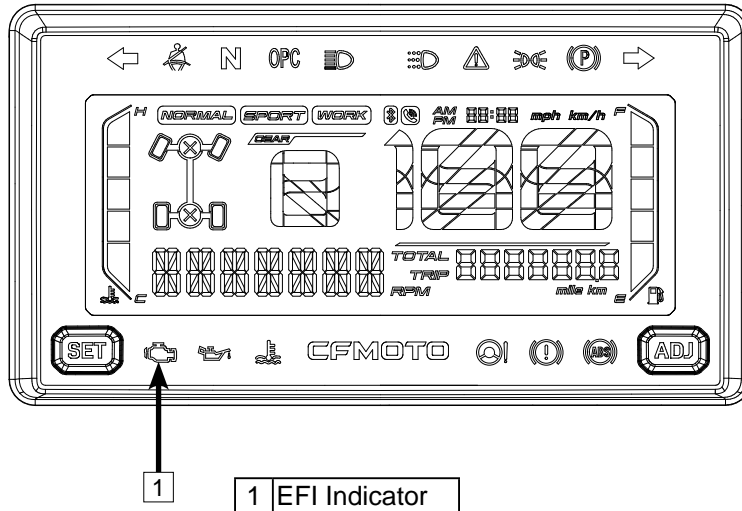

VEHICLE ISSUE DIAGNOSIS

EPS Malfunction Indicator Light

The Electronic Power Steering system on your vehicle contains a self-diagnostic feature that will illuminate the malfunction indicator light (MIL) if it detects a problem, when this indicator flashes, please contact your dealer. During normal operation, the EPS indicator will be on after the ignition switch is turned to ON, but EPS will not work. When the engine is started, the EPS indicator will be off and the EPS starts to function.

Fault code will display on the dashboard directly, record the fault code and contact your dealer for diagnosing. Your dealer has the EFI tool required to diagnose, repair and clear trouble codes.

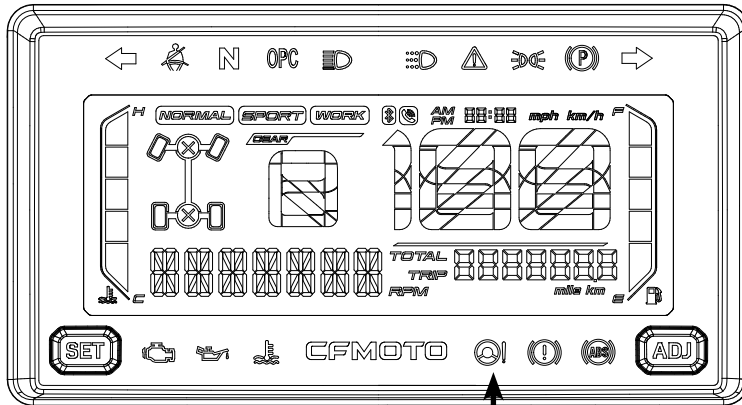

1 EPS Indicator

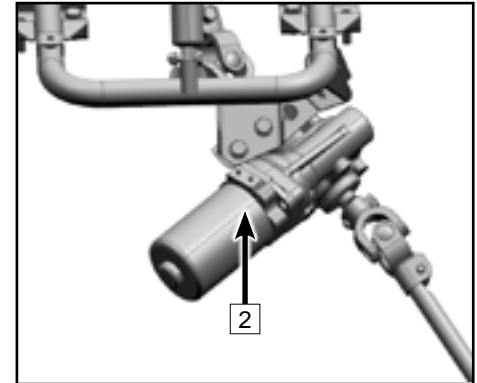

2 EPS

VEHICLE ISSUE DIAGNOSIS

Electronic Power Steering (EPS) Fault Diagnosis and Solution

Steering without assistance	<ol style="list-style-type: none"> 1. Wire connectors have bad contact or are disconnected 2. The fuse blew out 3. Relay damage 4. The controller, motor, or sensor is damaged 	<ol style="list-style-type: none"> 1. Check whether wire connectors and pins are fully inserted 2. Replace the fuse (40A) 3. Contact your dealer 4. Contact your dealer
Power assist doesn't weigh the same for left and right	<ol style="list-style-type: none"> 1. The median output voltage has deviation 2. Controller, motor or sensor is damaged 	<ol style="list-style-type: none"> 1. Contact your dealer 2. Contact your dealer
When system is 'ON', the steering swings to both sides	<ol style="list-style-type: none"> 1. Motor is mounted backwards 2. Controller or sensor is damaged 	<ol style="list-style-type: none"> 1. Contact your dealer 2. Contact your dealer
Steering becomes heavy	<ol style="list-style-type: none"> 1. Battery has power loss 2. Air pressure of the tires (front) is insufficient 3. Motor damage (power reduction) 	<ol style="list-style-type: none"> 1. Charge the battery 2. Inflate the tires 3. Contact your dealer
System has noise	<ol style="list-style-type: none"> 1. Motor damage 2. Gap of lower steering shaft assembly or mechanical steering assembly is too large 3. Installation of lower steering shaft assembly or mechanical steering assembly is loose 	<ol style="list-style-type: none"> 1. Contact your dealer 2. Contact your dealer 3. Contact your dealer

CFMOTO LIMITED WARRANTY FOR USA

CFMOTO Limited Warranty

Dear Customer,

Thank you for purchasing a CFMOTO product, if any component on your vehicle is found to be defective in materials or workmanship within the terms and conditions of this Limited Warranty, the defective component will be repaired or replaced (at the option of CFMOTO) without charge for parts and/or labor at any authorized dealer located within the United States. The CFMOTO Limited Warranty is subject to the following terms and conditions:

CFMOTO Warranty Terms & Conditions

- 1. WARRANTY DURATION:** The duration of the warranty period is one (1) year from the date of the new vehicle purchase from an authorized CFMOTO POWERSPORTS, Inc., Dealer. This warranty coverage is invoked from the purchase and use of CFMOTO vehicles only within the continental United States. During the warranty period, CFMOTO POWERSPORTS, Inc. will cover parts and labor costs incurred by an authorized CFMOTO POWERSPORTS, Inc. Dealer arising from a defect in material and/or workmanship of a CFMOTO vehicle. Any vehicles used for commercial purposes will have their warranty period reduced to six (6) months. If CFMOTO POWERSPORTS, Inc. covers a full engine replacement or a complete vehicle replacement under this warranty, the warranty period does not get extended and remains the same as the original purchase date of the vehicle at issue.
- 2. WARRANTY LIMITATIONS:** CFMOTO POWERSPORTS, Inc. provides warranty coverage for one (1) year on all parts and labor for all of its new CFMOTO ATVs. However, the following coverage, exceptions, and limitations apply to all CFMOTO vehicles:

CFMOTO LIMITED WARRANTY FOR USA

- A. A 30-DAY WARRANTY coverage period applies to all new CFMOTO vehicles in relation to the vehicle's:
- Battery
 - Spark Plugs
 - Air Filters
 - Oil and Fuel Filters
- B. A 90-DAY WARRANTY coverage period applies to all new CFMOTO vehicles in relation to the vehicle's:
- Drive Belt
 - Gear Shift, CVT, and Wet Clutch
 - Throttle and Brake Cables
 - Front/Rear Rims
 - Front/Rear Tires
 - Front/Rear Brake Pads or Shoes
 - Front/Rear Brake Discs or Drums
 - Wheel or Steering Stem Bearings and Seals
 - Rubber Parts/Engine Mounts/Grips/Boots
 - Brake or Clutch Levers
 - Floor Boards or Pegs
 - ATV Winch (if equipped)
 - Light Bulbs/Fuses
 - Body Plastics and Cosmetic Defects

CFMOTO LIMITED WARRANTY FOR USA

3. **EXCLUSIONS FROM WARRANTY COVERAGE:** Any Damage resulting from the following acts or circumstances is not covered by the CFMOTO POWERSPORTS, Inc., Limited Warranty:
 - Fire
 - Collision
 - Theft
 - Unavoidable natural disasters
 - Improper storage or transportation
 - Failure or negligence in the performance of periodic vehicle maintenance
 - Improper or negligent use or operation
 - Unauthorized repair or adjustment
 - Unauthorized modifications or performance upgrades
 - Use of vehicle as a rental vehicle
 - Use of vehicle in competitive or racing events
4. **VEHICLE CARE AND MAINTENANCE:** The vehicle's owner must properly use, maintain, and care for the vehicle as outlined in the CFMOTO POWERSPORTS, Inc., Owner's Manual. Any warranty repairs must be performed exclusively by CFMOTO POWERSPORTS, Inc., authorized Dealers. Any warranty work performed by anyone other than an authorized CFMOTO Dealer will not be covered under the CFMOTO POWERSPORTS, Inc., Limited Warranty policy.
5. **TRANSFER OR CONTINUATION OF WARRANTY:** This warranty is transferable only under the following conditions:
 - Transfer information must be provided to an authorized CFMOTO POWERSPORTS, Inc. dealer, who will then forward the information to CFMOTO POWERSPORTS, Inc.;

CFMOTO LIMITED WARRANTY FOR USA

- The complete model and serial number as shown on the original warranty document must be provided.
 - The name and address of the existing and new owners must be provided.
 - The original delivery date of the vehicle must be provided.
 - The new owner must indicate in writing that he/she has received and read the vehicle's Owner's Manual and the CFMOTO POWERSPORTS, Inc. Warranty Policy.
6. **WARRANTY REGISTRATION:** The Dealer must complete a PDI form and warranty register the vehicle online and provide the completed registration form to CFMOTO POWERSPORTS, Inc., within seven (7) days of completing the sale of the vehicle. Please note that NO warranty claims will be processed unless the product warranty online registration form is completed and the form is received by CFMOTO POWERSPORTS, Inc., from the Dealer.
7. **DEALER RESPONSIBILITIES:** A CFMOTO authorized Dealer must perform warranty coverage repairs at no charge to the customer, even if they are not the dealer that sold the CFMOTO vehicle to the customer, and must use CFMOTO OEM parts for all warranty repairs. All vehicles sold by the dealer must be inspected and tested by the dealer to ensure proper performance and operation prior to delivery to the customer. No vehicles may be delivered to a customer without first passing a dealer inspection and an operational test.
8. **CUSTOMER ASSISTANCE:** Any questions regarding your CFMOTO vehicle or related products should be directed to an authorized CFMOTO dealer. However, if a dealer is not available to answer customer concerns or address a technical issue with a CFMOTO vehicle or product, CFMOTO POWERSPORTS, Inc., customer representatives can be contacted directly at (763)398-2690 or by e-mail: info@cfmoutousa.com. Please note that Customer Service cannot approve or deny warranty, and cannot provide technical repair data, diagnosis, instruction, or other information beyond what is provided in the Owner's Manual.

CFMOTO LIMITED WARRANTY FOR USA

9. **COMMERCIAL USE.** The duration of the warranty for commercial use shall be limited to a period of six (6) months instead of one year for recreational use. All other conditions and limitations shall apply.
10. **TIRES PROVIDED AS ORIGINAL EQUIPMENT:** Other than provided herein, vehicle tires supplied as original equipment are warranted separately by the individual tire manufacturer or its representatives.
11. **DISCLAIMER:** NO EXPRESS WARRANTY IS PROVIDED BY CFMOTO POWERSPORTS, INC. WITH RESPECT TO CFMOTO VEHICLES EXCEPT AS SPECIFICALLY SET FORTH HEREIN. ANY IMPLIED WARRANTY, WARRANTY OF MERCHANTABILITY, WARRANTY OF FITNESS FOR A PARTICULAR PURPOSE, AND ALL IMPLIED WARRANTIES ARISING FROM A COURSE OF DEALING, USAGE OF TRADE, BY STATUTE OR OTHERWISE, ARE HEREBY STRICTLY LIMITED TO THE TERMS OF THIS WRITTEN LIMITED WARRANTY.
12. **INTEGRATION:** This limited warranty supersedes any and all oral, express, or written warranties, statements, or undertakings that may previously have been made, and contains the entire agreement of the parties with respect to the warranty of CFMOTO vehicles. Any and all warranties not contained in this Agreement are specifically excluded. This warranty extends to each original (and subsequent) owner of any CFMOTO ATV, for the term of the original warranty period. This limited warranty shall be the sole and exclusive remedy available to the customer with respect to the covered CFMOTO vehicle. In the event of any alleged breach of any warranty or any legal action brought by the customer based on alleged negligence or other conduct by CFMOTO POWERSPORTS Inc., or its related parties, the customer's sole and exclusive remedy will be repair or replacement of defective components as stated above, unless otherwise provided by law. Some states do not allow limitations on how long an implied warranty lasts, so the above limitations may not apply if they are deemed inconsistent with the controlling state law.

CFMOTO LIMITED WARRANTY FOR USA

California Evaporative Emissions Control Warranty Statement Your Warranty Rights and Obligations

INTRODUCTION:

The California Air Resources Board (CARB) and CFMOTO Powersports, Inc. (CFMOTO) are pleased to explain the evaporative emissions control system warranty on your 2020 and later-model year off-highway recreation vehicles (OHRVs). In California, new off-highway recreational vehicles must be designed, built, and equipped to meet the State's stringent anti-smog standards. CFMOTO must warrant the evaporative emissions control system on your OHRV for the periods of time listed below, provided there has been no abuse, neglect, improper maintenance, or unapproved modification of your OHRV.

Your evaporative emissions control system may include parts such as: fuel injection systems, electronic control systems, fuel tanks, fuel lines, fuel caps, valves, carbon canisters, filters, vapor hoses, belts, clamps, connectors, and other evaporative emissions-related components. Where a warrantable condition exists, CFMOTO will repair your OHRV at no cost to you, including diagnosis, parts and labor.

MANUFACTURER'S WARRANTY COVERAGE:

The warranty period for this OHRV is 30 months, or 2500 miles, or 250 hours, whichever comes first, except for "high-priced" warranty parts, which are covered for 60 months, or 5000 miles, or 500 hours, whichever comes first. If any evaporative emissions-related part on your OHRV is defective, the part will be repaired or replaced by CFMOTO.

OWNER'S WARRANTY RESPONSIBILITIES:

As the OHRV owner, you are responsible for the performance of the required maintenance listed in your owner's manual. CFMOTO recommends that you retain all receipts covering maintenance on your OHRV, but CFMOTO cannot deny warranty solely for the lack of receipts or for your failure to ensure the performance of a scheduled maintenance.

As an owner, you are responsible for presenting your OHRV to a CFMOTO dealer as soon as a problem

CFMOTO LIMITED WARRANTY FOR USA

exists. The warranty repairs should be completed in a reasonable amount of time, not to exceed 30 days. As an OHRV owner, you should also be aware that CFMOTO may deny you warranty coverage if your OHRV or a part has failed due to abuse, neglect, improper maintenance or unapproved modifications.

WARRANTY PARTS:

The repair or replacement of any warranted part otherwise eligible for warranty coverage may be excluded from such coverage if CFMOTO demonstrates that the OHRV has been abused, neglected, or improperly maintained, and that such abuse, neglect, or improper maintenance was the direct cause of the need for repair or replacement of the part. That notwithstanding, any adjustment of a component that has a factory installed, and properly operating, adjustment-limiting device is still eligible for warranty coverage. The following emission warranty parts list are covered:

- Fuel Tank^{\$}
- Fuel Cap
- Fuel Lines
- Fuel Lines Fittings
- Clamps
- Pressure Relief Valves*
- Control Valves*
- Control Solenoids*
- Electronic Control*
- Electronic Control Module*^{\$}
- Vacuum Control Diaphragms*
- Control Cables*
- Control Linkages*
- Purge Valves
- Vapor Hoses
- Liquid/Vapor Separator
- Carbon Canister
- Canister Mounting Brackets

*Parts that relate to the installed vehicle Evaporative Control System; ^{\$}High-Priced warranty parts.

THE REMOVAL OR MODIFICATION OF EVAPORATIVE EMISSION-RELATED PARTS ON THIS OHRV IS ILLEGAL. VIOLATORS MAY BE SUBJECT TO CIVIL AND/OR CRIMINAL PENALTIES AS PROVIDED UNDER CALIFORNIA AND FEDERAL LAW.

If you have any questions regarding your warranty rights and responsibilities, you should contact CFMOTO at 763 398-2690; 555 Holly Lane N. Suite #30 Plymouth, MN 55447 or the California Air Resources Board at 9528 Telstar Avenue, El Monte, CA 91731.

CFMOTO LIMITED WARRANTY FOR USA

U.S.A. EPA and CARB Emissions Control Limited Warranty

This emissions limited warranty is in addition to the CFMOTO Powersports, Inc. standard limited warranty for your vehicle. CFMOTO Powersports, Inc. warrants that at the time it is first purchased, this emissions-certified vehicle is designed, built and equipped so it conforms to applicable U.S. Environmental Protection Agency (EPA) and the California Air Resource Board (CARB) emission regulations. CFMOTO Powersports, Inc. also warrants that the vehicle is free from defects in materials and workmanship that would cause it to fail to meet these regulations.

The warranty period for this emissions-certified vehicle starts on the date the vehicle is first purchased and continues for a period of 500 hours of engine operation, 5000 kilometers (3,100 miles) of vehicle travel, or 30 calendar months from the date of purchase, whichever comes first. This emissions limited warranty covers components whose failure increases the vehicle's regulated emissions, and it covers components of systems whose only purpose is to control emissions. Repairing or replacing other components not covered by this warranty is the responsibility of the vehicle owner. This emissions limited warranty does not cover components whose failure does not increase the vehicle's regulated emissions.

For exhaust emissions, emission-related components include any engine parts related to the following systems:

- Air-induction system (excludes filters)
- Fuel system (excludes pumps and filters)
- Ignition system (excludes spark plugs)
- Exhaust gas recirculation systems

The following parts are also considered emission-related components for exhaust emissions:

- After treatment devices
- Crankcase ventilation valves
- Sensors
- Electronic control units

CFMOTO LIMITED WARRANTY FOR USA

The following parts are considered emission-related components for evaporative emissions:

- Fuel Tank
- Fuel Cap
- Fuel Line
- Fuel Line Fittings
- Clamps*
- Pressure Relief Valves*
- Control Valves*
- Electronic Controls*
- Vacuum Control Diaphragms*
- Control Cables*
- Control Linkages*
- Purge Valves
- Vapor Hoses
- Liquid/Vapor Separator
- Carbon Canister
- Carburetor Purge Port Connector

* As related to the evaporative emission control system.

The exclusive remedy for breach of this limited warranty shall be, at the exclusive option of CFMOTO Powersports, Inc., repair or replacement of any defective materials, components or products.

THE REMEDIES SET FORTH IN THIS LIMITED WARRANTY ARE THE ONLY REMEDIES AVAILABLE TO ANY PERSON FOR BREACH OF THIS WARRANTY. CFMOTO POWERSPORTS, INC. SHALL HAVE NO LIABILITY TO ANY PERSON FOR INCIDENTAL, CONSEQUENTIAL OR SPECIAL DAMAGES OF ANY DESCRIPTION, WHETHER ARISING OUT OF EXPRESS OR IMPLIED WARRANTY OR ANY OTHER CONTRACT, NEGLIGENCE OR OTHER TORT OR OTHERWISE. THIS EXCLUSION OF CONSEQUENTIAL, INCIDENTAL, AND SPECIAL DAMAGES IS INDEPENDENT FROM AND SHALL SURVIVE ANY FINDING THAT THE EXCLUSIVE REMEDY FAILED OF ITS ESSENTIAL PURPOSE.

CFMOTO LIMITED WARRANTY FOR USA

ALL IMPLIED WARRANTIES (INCLUDING BUT NOT LIMITED TO ANY IMPLIED WARRANTIES OF MERCHANTABILITY AND FITNESS FOR A PARTICULAR PURPOSE) ARE LIMITED IN DURATION TO THE WARRANTY PERIOD DESCRIBED HEREIN. CFMOTO POWERSPORTS, INC. DISCLAIMS ALL EXPRESS WARRANTIES NOT STATED IN THIS WARRANTY.

Some states do not allow limitations on how long an implied warranty lasts, so the above limitation may not apply if it is inconsistent with the controlling state law. This limited warranty excludes failures not caused by a defect in material or workmanship. This limited warranty does not cover damage due to accidents, abuse or improper handling, maintenance or use. This limited warranty also does not cover any engine that has been structurally altered, or when the vehicle has been used in racing competition. This limited warranty also does not cover physical damage, corrosion, or defects caused by fire, explosions or other similar causes beyond the control of CFMOTO Powersports, Inc. Owners are responsible for performing the scheduled maintenance identified in the owner's manual. CFMOTO Powersports, Inc. may deny warranty claims for failures that have been caused by the owner's or operator's improper maintenance or use, by accidents for which CFMOTO Powersports, Inc. has no responsibility, or by acts of God. Any qualified repair shop or person may maintain, replace, or repair the emission control devices or systems on your vehicle. CFMOTO Powersports, Inc. recommends that you contact an authorized CFMOTO Powersports, Inc. dealer to perform any service that may be necessary for your vehicle. CFMOTO Powersports, Inc. also recommends that you use only genuine CFMOTO Powersports, Inc. parts. It is a potential violation of the Clean Air Act if a part supplied by an aftermarket parts manufacturer reduces the effectiveness of the vehicle's emission controls. Tampering with emission controls is prohibited by federal law. If you have any questions regarding your warranty rights and responsibilities, please contact CFMOTO Powersports, Inc. at 888-823-6686.

CFMOTO LIMITED WARRANTY FOR USA

Noise Control System and Tampering

Warranty time period: **1,865 miles (3000 km)**

Federal law prohibits the following acts or causing thereof:

1. The removal or rendering inoperative by any person other than for purposes of maintenance, repair, or replacement, of any device or element of design incorporated into any new vehicle for the purpose of noise control prior to its sale or delivery to the ultimate purchaser or while it is in use or;
2. The use of the vehicle after such device or element of design has been removed or rendered inoperative by any person.

AMONG THOSE ACTS PRESUMED TO CONSTITUTE TAMPERING ARE THE ACTS LISTED BELOW:

These acts include tampering with the following systems; i.e., modification, removal, etc.

Exhaust system

- Muffler
- Exhaust
- Silencer

Intake system

- Air cleaner case
- Air cleaner element
- Intake duct

CFMOTO LIMITED WARRANTY FOR USA

Change of Ownership

If you sell your vehicle, any valid remainder of the warranty can be transferred to the new owner. Please record the details of the exchange below and inform an authorized CFMOTO dealer:

Change of Ownership	Original Purchaser	2nd Owner	3rd Owner	4th Owner
Owner Name				
Address				
City				
State / Zip Code				
Telephone				
E-mail				
Date of Purchase				
Odometer Reading				
New Owner Signature				

NOTE:

If a completed Change of Ownership form does not include the required details or is inaccurate, CFMOTO reserves the right to investigate the actual ownership of the product, the service history, and possibly refuse the application for warranty transfer if the requirements have not been fulfilled.

A	Accessory Power Ports.....	65	Change the Engine Oil.....	136
	Age Restrictions.....	18	Change the Wheel.....	161
	Air Filter Maintenance.....	132	Cleaning and Storage.....	167
	Avoid Carbon Monoxide Poisoning.....	19	Cleaning the Radiator.....	146
	Avoid Gasoline Fires and Other Hazards.....	20	Controls and Features.....	52
B	Battery.....	151	Cooling System.....	143
	Battery Charging.....	154	Cup Holder.....	65
	Battery Installation.....	153	CVT System.....	71
	Battery maintenance.....	152	D	
	Battery Removal.....	152	Dashboard Indicators and Warnings.....	75
	Be Qualified and Responsible.....	22	Dashboard Navigation / Settings / Adjustments.....	83
	Brake Fluid Change.....	157	Drain Bolt Torque.....	137
	Brake Light Operation.....	157	Drying a Wet CVT System.....	142
	Brake Pad Inspection.....	156	Drying the Air Filter Housing after Submersion.....	133
	Brake Pedal.....	56	E	
	Brakes.....	155	ECU and Fault Diagnosis Connector.....	69
	Break-In Maintenance Checklist.....	122	EFI Malfunction Indicator Light.....	177
	Break-In Period.....	84	Electrical.....	162
C	Cargo Box and Tilt Feature.....	67	Electronic Power Steering (EPS) Fault Diagnosis and Solution.....	179
	Carrying a Passenger.....	22	Electronic Throttle Pedal.....	57
	CFMOTO Limited Warranty.....	180	Engine Air Intake Deflector.....	134
	CFMOTO Warranty Terms & Conditions.....	180	Engine Backfires.....	175
	Change of Ownership.....	191	Engine Does not Turn Over.....	172
	Change the Coolant.....	144	Engine Idle Speed.....	138
			Engine Pings or Knocks.....	172
			Engine Stops or Loses Power.....	173

Engine turns over, Fails to start	175		Introduction	10
Engine Turns Over, Fails to Start.....	174	K	Key Switch	56
Engine Valve Clearance Adjustment.....	138		Know Your Vehicle	18
EPS Malfunction Indicator Light.....	178	L	LH & RH Front Hood Clasps.....	65
Equipment Modifications.....	19	M	Main Fuse and EPS Fuse.....	163
EVAP System.....	6		Maintenance	118
Exhaust Pipe Spark Plug Arrestor	150		Maintenance Procedures.....	131
F		N	Noise Control System and Tampering	190
Foot Brake	87	O	Occupant Protection	52
Foreword.....	5		Occupant Restraint System	24
Front and Rear Axle Boots.....	141		Operating Your Vehicle	84, 98
Front and Rear Gear Case	139		Operator Safety	18
Fuel Cap	65		Owner Responsibilities	22
Fuel Minimum Octane Rating and Safety Warnings	20		P	
Fuse Box.....	162		Periodic Maintenance Schedule	124
G			Potential Hazard Warnings	34
Gear Shift Lever.....	55		Practice Exercises	95
General Safety Precautions	18		Pre-Ride Inspection	86
Glove Box	65		Pre-Ride Maintenance Checklist	120
H			Primary Controls	54
Hand Brake	54			
Hauling and Towing Loads.....	103			
Headlight Adjustment.....	164			
How to Avoid CVT Drive Belt and Clutch Failures ...	72			
I		Q		
Indicators and Warnings	76			
Inspect The Engine Oil Level.....	135	R		

Recommended Engine Oil Viscosity.....	85	T	Terrain Conditions.....	24
Responsibilities of the Operator.....	92		Throttle.....	86
Riding Carefully	23		Tilt Lever and Steering Wheel Lock.....	55
Roll Over Protection System (ROPS).....	24		Transporting the Vehicle	171
S		U		
Safe Operation - Driving Safely	92		U.S.A. EPA and CARB Emissions Control Limited	
Safe Riding Gear	26		Warranty	187
Safety Belt	165	V		
Safety Labels, Locations and Warnings.....	27		Vehicle Features	65
Seat	67		Vehicle Identification Numbers and Key Information	11
Seat Storage.....	68		Vehicle Issue Diagnosis.....	172
Secondary Controls	58		Vehicle Recovery Methods	113
Severe Use Definition	118	W		
Shifting the Transmission.....	88		Welcome	5
Shock Absorber Adjustment.....	159		Wheels.....	160
Signal Words.....	7		Winch.....	69
Spark Plug Removal and Inspection.....	148		Winch Cable Care.....	114
Spark Plug Removal to Expel Water from the Engine			Winch Cable Spooling Guidelines	115
.....	149		Winch Operation	108
Spark Plug(s).....	147		Winch ‘Shock Loading’	116
Specifications.....	12		Wired Winch Cable Controller Power Port.....	70
Starting a Cold Engine	87		Wireless Winch Remote Control.....	70
Starting the Engine	87			
Steering Wheel	54			
Suspension	157			
Suspension Lubricating and Adjustment.....	158			
Switch	58			

5ASV-380101-6202-13 US218

ZHEJIANG CFMOTO POWER CO., LTD.

MANUFACTURED BY:

ZHEJIANG CFMOTO POWER CO., LTD.

Add:NO.116,Wuzhou Road, Yuhang Economic Development Zone, Hangzhou 311100, Zhejiang Province, China

Tel:86-571-86258863

Fax:+86-571-89265788

E-mail:service@cfmoto.com.cn

<http://global.cfmoto.com>

DISTRIBUTED BY:

CFMOTO POWERSPORTS INC.

3555 Holly Lane N. Suite #30, Plymouth MN, 55447, USA

Toll free: (888) 8-CFMOTO (823-6686)

Tel: (1) 763-398-2690

Fax: (1) 763-398-2695

www.cfmotousa.com

DISTRIBUTED BY

CANADA MOTOR IMPORT INC.

24 rue Industrielle, Saint-Benoît Labre,

Québec, Canada, G0M 1P0

Tel:418-227-2077

www.cfmoto.ca