

CFORCE

600

CFORCE

600 TOURING

OWNER'S MANUAL



READ THIS MANUAL CAREFULLY

It contains important safety information
This ROV should not be ridden by anyone under 16
years of age. Passenger under 12 are prohibited.

TABLE OF CONTENTS

Foreword	1
Welcome	1
EVAP System (Evaporative Emission Control System)	2
Catalytic Converter.....	2
Signal Words.....	3
Introduction	8
Vehicle Identification Number.....	9
Specification.....	10
Operator Safety	17
Equipment Modifications	18
Safety Training	19
Hazardous Operation Warnings.....	19
Safe Riding Gear.....	44
Safety Decals and Locations.....	45
Features & Controls	53
Left Hand Controls	53
Right Hand Controls.....	57
Foot Brake.....	62
Fuel Tank.....	64

Transmission Gear Selector	66
CVT System	68
Engine Braking System (EBS)	69
Avoiding CVT drive belt and component problems	70
Vehicle Features	72
Winch Operation	78
Dashboard Indicators and Warnings	90
Operation of your ATV	99
Break-In Period	99
Pre-Ride Inspection.....	101
Starting the Engine.....	102
Gear Selector Operation	104
Hauling Cargo	107
Driving Safely	110
Maintenance Schedule	127
Pre-Ride Maintenance Checklist.....	130
Break-In Maintenance Checklist	132
Periodic Maintenance Schedule.....	134
Maintenance Procedures	141
Cleaning & Storage	184
Transporting the ATV.....	189

Vehicle Issue Diagnosis.....	190
Engine doesn' t turn over	190
Engine Pings or Knocks	190
Engine Stops or loses power	191
Engine Turns Over, Fails to Start	191
Engine Backfires	192
Engine Runs Irregularly, Stalls or Misfires.....	192
Engine Runs Irregularly, Stalls or Misfires.....	193
Engine Stops or Loses Power.....	194
EFI Malfunction Indicator Light.....	195
EPS Malfunction Indicator Light.....	196
CFMOTO Limited Warranty For USA	198
WARRANTY TERMS & CONDITIONS	198
CALIFORNIA EVAPORATIVE EMISSIONS CONTROL WARRANTY STATEMENT ..	204
U.S.A. EPA and CARB Emissions Control Limited Warranty	206
Noise Control System and Tampering.....	210
CHANGE OF OWNERSHIP.....	211

FOREWORD

Foreword

Welcome

Thank you for purchasing a CFMOTO vehicle, and welcome to our world-wide family of CFMOTO enthusiasts. Be sure to visit us online at www.cfmoto.com for the latest news, new product introductions, upcoming events, and more.

CFMOTO is an international company that specializes in the development, manufacture, and marketing of all-terrain vehicles, utility vehicles, large displacement motorcycles, and their core components. Founded in 1989, CFMOTO is devoted to the development of independent brand cultivation and R&D innovation. CFMOTO products are currently distributed through more than 2000 companions worldwide in more than 100 countries and regions. CFMOTO is edging into the advanced ranks in the world of powersports, and aims to supply superior products to dealers and fans globally.

For safe and enjoyable operation of your vehicle, be sure to follow the instructions and recommendations in this owner's manual. Your manual contains instructions for minor maintenance. Information about major repairs is outlined in the CFMOTO Service Manual. Your CFMOTO dealer knows your vehicle best and is interested in your total satisfaction. Be sure to return to your dealership for all of your service needs during, and after, the warranty period.

Due to constant improvements in the design, quality, or configuration of production components, some minor discrepancies may result between the actual vehicle and the information presented in this manual. CFMOTO reserves the right to change features, specifications and components without notice or incurring obligation to the purchaser. Depictions and/or procedures within are intended for reference use only. The most current version of this manual may be available on CFMOTO consumer website of the market you reside in.

This manual applies to the following models: CF600AU-3SA, CF600AZ-3SA, CT600AZ-3SA, CF600AU-3LA, CF600AZ-3LA, CT600AZ-3LA

FOREWORD

WARNING

The engine exhaust from this product contains chemicals known to the State of California to cause cancer, birth defects or other reproductive harm.

EVAP System (Evaporative Emission Control System)

(If equipped)

When required by environmental emissions regulations, this vehicle is manufactured with a fuel evaporation system (EVAP) to prevent fuel vapors entering the atmosphere from the fuel tank and fuel system.

During routine maintenance, visually inspect all hose connections for leaks or blockage. Ensure the hoses are not clogged or kinked, which could damage the fuel pump or distort the fuel tank. No other maintenance is necessary.

Contact your dealer if repair is required. Do not modify the EVAP system. Modifying any part of this system will violate environmental emissions regulations.

Catalytic Converter

CAUTION: Please pay attention to the following to protect your catalytic converter:

- Use only unleaded gasoline. Even gasoline that contains a little lead could damage the reactive metals contained in the catalytic converter and disable it.
- Never add rust preventive oil or engine oil into the muffler. Doing so could damage the catalytic converter.

NOTE

Some features described within this manual may not apply to models sold in North America.

All descriptions and directions given are from the operator's perspective when properly seated.

FOREWORD

Signal Words

A signal word calls attention to a safety message or messages, a property damage message or messages, and designates a degree or level of hazard seriousness. The standard signal words in this manual are WARNING, CAUTION and NOTE or NOTICE.

The following signal words and symbols appear throughout this manual and on your vehicle. Your safety is involved when these words and symbols are used. Become familiar with their meanings before reading the manual:

WARNING

This safety alert and icon indicates a potential hazard that may result in serious injury or death.

CAUTION

This safety alert and icon indicates a potential hazard that may result in minor or moderate personal injury and/or damage to the vehicle.

CAUTION

This safety alert without an icon indicates a situation that may result in damage to the vehicle.

NOTE or NOTICE

A note or notice will alert you to important information or instructions

FOREWORD
⚠️ WARNING FOR TYPE I ATVs
(1-person vehicle)

Improper vehicle use can result in SEVERE INJURY or DEATH



**ALWAYS
USE AN
APPROVED
HELMET AND
PROTECTIVE
GEAR**



**NEVER USE
ON PUBLIC
ROADS**



**NEVER CARRY
PASSENGERS**



**NEVER
USE WITH
DRUGS OR
ALCOHOL**

FOREWORD
⚠️ WARNING FOR TYPE II ATVs
(2-person vehicle)

Improper vehicle use can result in SEVERE INJURY or DEATH



**ALWAYS
USE AN
APPROVED
HELMET AND
PROTECTIVE
GEAR FOR
DRIVER AND
PASSENGER**



**NEVER USE
ON PUBLIC
ROADS**



**NEVER
CARRY MORE
THAN ONE
PASSENGER**



**NEVER
USE WITH
DRUGS OR
ALCOHOL**

FOREWORD

NEVER:

- Operate without proper training or instruction.
- Operate on public roads. A collision can occur with another vehicle.
- Operate at speeds too fast for your skill or the conditions.
- Carry multiple passengers, Type II ATVs are designed for a single passenger only.
- Use ALCOHOL or DRUGS before or while driving this vehicle.

ALWAYS:

- Avoid paved surfaces, which may adversely affect the handling and control.
- Use proper riding techniques to avoid vehicle overturn on hills and rough terrain, and when turning.
- Wear eye protection, helmet and protective clothing.

FOREWORD
READ THE OWNER'S MANUAL

FOLLOW ALL INSTRUCTIONS AND WARNINGS

 **WARNING**

Read, understand, and follow all of the instructions and safety precautions in this manual and on all product labels. Failure to follow the safety precautions could result in serious injury or death.

 **WARNING**

The engine exhaust gas from this product contains carbon monoxide, which is a deadly gas and could cause headaches, giddiness, loss of consciousness, or even death.

INTRODUCTION

Introduction

Thank you for purchasing a CFMOTO vehicle, and welcome to our world-wide family of CFMOTO enthusiasts.

For safe and enjoyable operation of your vehicle, be sure to follow the instructions and recommendations in this owner's manual. Information about major repairs are outlined in the CFMOTO Service Manual, and should only be performed by a CFMOTO service dealer and technician. Be sure to return to your dealership for all of your service needs during, and after, the warranty period.

If you have questions or concerns about your vehicle

All questions or concerns related to your vehicle should be directed to your local CFMOTO dealer first. Your dealer knows your vehicle best and is interested in your total satisfaction. In the event your local dealer is unable to resolve a product issue or concern, you can reach a CFMOTO customer service representative depending on the market you reside in:

For USA: Please contact CFMOTO POWERSPORTS, INC. TEL: 763-398-2690, by e-mail: info@cfmotousa.com, or online: <https://cfmotousa.com/customer-care/customer-care-contact>. Please note that customer service does not have authority to approve or deny warranty, and cannot provide technical repair data, diagnosis, or instructions.

For CANADA: Please contact CANADA MOTOR IMPORT INC. TEL: 1-418-227-2077, or online: <https://www.cfmoto.ca/en/customer-care/>.

For a safety concern related to your Canadian vehicle, you may report your concern to Transport Canada Defect Investigation and Recalls Division by mail, telephone, or online using the contact information below:

Mailing address: Transport Canada - ASFAD, 330 Sparks Street, Ottawa, ON, K1A 0N5

TEL: 819-994-3328 (Ottawa-Gatineau area or international) or toll-free: 1-800-333-0510 (In Canada)

Online: <http://www.tc.gc.ca/recalls>

INTRODUCTION

Vehicle Identification Number

Record your vehicle's identification numbers in the spaces provided. Remove the spare key and store in a safe place. Your key can be duplicated only by mating a key blank with one of your existing keys.

If both keys are lost, the complete lock assembly must be replaced.

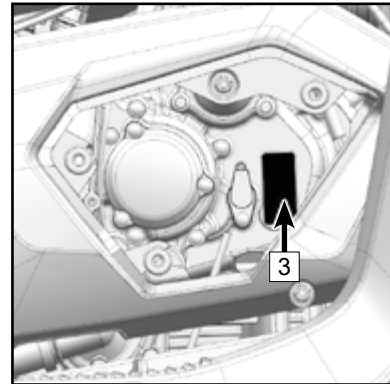
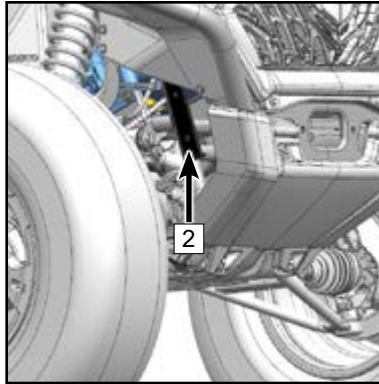
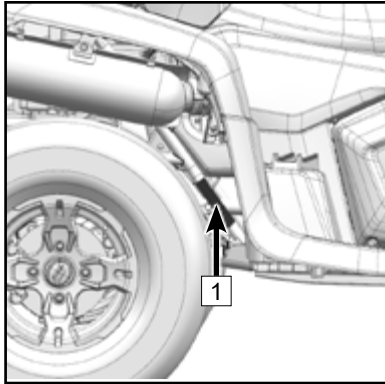

1 Vehicle identification number: _____

2 Vehicle model number: _____

3 Engine serial number: _____

SPECIFICATION

Specification

Item	CFORCE 600	CFORCE 600 TOURING
Overall Length	2035 mm	2235 mm
Overall Width	1180 mm	1180 mm
Overall Height	1220 mm	1390 mm
Wheel Base	1280 mm	1480 mm
Ground Clearance	270 mm	
Minimum Turning radius	3625 mm	3700 mm
Basic Weight	395 kg	415 kg
Front Rack Load Capacity	20 kg	
Rear Rack Load Capacity	40 kg	
Maximum Vehicle Load Allowed	170kg	250 kg
Recommended Towing Capacities:		
Towing Hitch Weight	25 kg	
Trailer and Cargo Weight	150 kg	
Engine Model And Type	Single cylinder, liquid cooling, 4 stroke, SOHC, valves	
Type	191S	

SPECIFICATION

Item	Specifications
Bore × Stroke	91 mm × 89.2 mm
Displacement	580 cc
Compression Ratio	10.68 : 1
Starting Type	ECU ignition
Lubrication Type	Splash lubrication
Engine Coolant: Type	Commercially available – Safe for aluminum engines
Coolant Volume	2.3 qt (2.18 L)
Mix Ratio	50% coolant / 50% distilled water
Engine Oil: Type	SAE 10W-40 /SAE 5W-40 /SAE 15W-40
Engine Oil Volume: Capacity Change / Oil Filter	2.96 qt (2.8 L)

SPECIFICATION

Item	Specifications
Rear gear case Oil:	
Type	SAE80W/90GL-5
Volume:	6.7 oz (200 mL)
Periodic Oil Change	6.7 oz (200 mL)
Front Gear Case Oil:	
Type	SAE80W/90GL-5
Volume	7.7 oz (230 mL)
Periodic Oil Change	7.7 oz (230 mL)
Air Filter	Paper filter element with foam pre-filter
Fuel Type	89# and above
Fuel Tank Capacity	4.75 gal (18 L)
Fuel Reserve Amount At Fuel Gauge 'Flash' (Approximate)	1.05 gal (4 L)

SPECIFICATION

Item		Specifications	
Spark Plug Type		DCPR8E/NGK	
Spark Plug Gap		0.8 mm ~ 0.9 mm	
Transmission	Transmission	CVT+gear shift	
	Gear Shift/Order	Manual L/H/N/R/P	
	CVT Ratio	0.67 ~ 3.02	
	Gear Ratio	Low Gear	2.533
		High Gear	1.35
Reverse		2.071	
Chassis Frame		Steel tube	
Tires:			
Type		Tubeless	
Front		25×8.0-12	
Rear		25×10.0-12	
Wheel Bolt Pattern		4x110mm	

SPECIFICATION

Item	Specifications
Tire Pressure:	
Front	45 kPa
Rear	45 kPa
Brake System:	Front: hydraulic disc
	Rear: hydraulic disc
Foot Brake Type / Operation	Front/rear united brake Operated by right foot
Hand Brake Type / Operation	Operated by right hand
Parking Brake Type / Operation	Hydraulic parking brake Operated by both hand and foot
Brake Fluid Type	DOT4
Suspension:	
Front Suspension	Double A-arm and independent
Rear Suspension	Double A-arm and independent

SPECIFICATION

Item	Specifications
Shock Absorber:	
Front Shock Absorber	Hydraulic damping / oil damper
Rear Shock Absorber	Hydraulic damping / oil damper
Wheel Travel:	
Front Wheel Travel	160 mm
Rear Wheel Travel	210 mm
Electrical System:	
Ignition	ECU ignition
Charging	A/C 600 Watt @ 5000 rpm
Battery	12 Vdc / 30 Amp Hr

SPECIFICATION

Item	Specifications
Light System:	
Head Lamp, Low Beam	LED 14.4W×2
Head Lamp, High Beam	LED 28.5W×4
Front Position Light	LED 3.6W×2
Tail Light/Brake Light	LED 2.9W×2 / LED 2W×2
Dashboard	LED and LCD -- non-maintenance

OPERATOR SAFETY

Operator Safety

WARNING

Failure to heed the warnings contained in this manual can result in serious injury or death. An ATV is not a toy and can be hazardous to operate. This vehicle handles differently from other vehicles, such as motorcycles and cars. A collision or rollover can occur quickly, even during routine maneuvers like turning, or driving over obstacles, if you fail to take proper precautions.

Read this owner's manual. Understand all safety warnings, precautions, and operating procedures before operating this ATV.

A packet containing important ATV safety information should be present with the owner's manual. If you cannot locate this packet, or if it has been removed, please contact your dealer.

Age Restrictions

This vehicle is an **ADULT VEHICLE ONLY**. Operation is prohibited for anyone under the age of 16. No passengers under age 12 are allowed on CFMOTO vehicles designed to carry a passenger.

Know Your Vehicle

As the operator of the vehicle, you are responsible for your personal safety, the safety of others, and the protection of our environment. Read and understand your owner's manual, which includes valuable information about all aspects of your vehicle, including safe operating procedures.

OPERATOR SAFETY

Equipment Modifications

CFMOTO is concerned with the safety of our customers and for the general public. Therefore, we strongly recommend that consumers do not install on a vehicle, any equipment that may increase the speed or power of the vehicle, or make any other modifications to the vehicle for these purposes. Any modifications to the original equipment of the vehicle create a substantial safety hazard and increase the risk of body injury. The warranty on your vehicle is terminated if any unapproved accessory equipment has been added to the vehicle, or if any modifications have been made to the vehicle that increase its speed or power.

NOTE

The addition of certain accessory equipment which may change the handling and performance characteristics of the vehicle include, but are not limited to mowers, plow blades, oversize tires, sprayers, large racks, lift kits and trailers. Use only approved accessories, and familiarize yourself with their function and effect on the vehicle.

OPERATOR SAFETY

Safety Training

When you purchased your new ATV, your dealer offered a hands-on safety training course that covers all aspects of vehicle safety. You were also provided with printed materials that explain safe operating procedures. You should review this information on a regular basis. If you purchased a used ATV from a party other than a dealer, you can request safety training from any authorized dealer.

Familiarize yourself with all laws and regulations concerning the operation of this vehicle in your area. CFMOTO strongly advises you to strictly follow the recommended maintenance program outlined in your owner's manual. This preventive maintenance program is designed to ensure that all critical components on your vehicle are thoroughly inspected at specific intervals. The following signal words and symbols appear throughout this manual and on your ATV. Your safety is involved when these words and symbols are used. Be familiar with their meanings before reading the manual.

Hazardous Operation Warnings

Serious injury or death can result if you do not follow the following instructions and procedures outlined in further detail within your owner's manual:

WARNING

- Read this manual and all labels carefully, and follow the operating procedures described.
- Never operate an ATV without proper instruction. Take a training course. Beginners should receive training from a certified instructor. Contact an authorized dealer to find out about the training courses nearest you.
- Never allow anyone under 16 years of age to operate the vehicle.
- Never permit a guest to operate the ATV unless the guest has read this manual, all product labels, and

OPERATOR SAFETY

has completed a certified safety training course.

- Never operate an ATV without wearing an approved helmet that fits properly . Always wear eye protection (goggles or face shield), gloves, boots, a long-sleeved shirt or jacket, and long pants.
- Never consume alcohol or drugs before or while operating an ATV.
- Never operate at excessive speeds. Travel at speeds appropriate for the terrain, visibility and operating conditions, and your experience.
- Never attempt wheelies, jumps or other stunts.
- Always inspect your ATV before each use to make sure it's in safe operating condition.
- Always follow the inspection and maintenance procedures and schedules outlined in your owner's manual.
- Always keep both hands on the handlebars and both feet on the footrest of the ATV during operation.
- Always travel slowly and use extra caution when operating on unfamiliar terrain. Be alert .to terrain conditions.
- Never operate on excessively rough, slippery, or loose terrain.
- Always follow proper turning procedures as described in this manual. Practice turning at low speeds before attempting to turn at faster speeds. Do not turn at excessive speeds.
- Always have the ATV inspected by an authorized dealer if it's been involved in an accident.
- Never operate on hills too steep for the ATV or for your abilities. Practice on smaller hills before attempting larger hills.
- Always follow proper procedures for climbing hills . Check the terrain carefully before ascending a hill.
- Never climb hills with excessively slippery or loose surface. Shift your weight forward.
- Never open the throttle suddenly or make sudden gear changes.

OPERATOR SAFETY

- Never go over the top of a hill at high speed.
- Always follow proper procedures for going downhill and for braking on hills. Check the terrain carefully before you start down a hill. Shift your weight backward. Never go down a hill at high speed. Avoid going down a hill at an angle, which would cause the vehicle to lean sharply to one side. Travel straight down the hill when possible.
- Always follow proper procedures for crossing the side of a hill. Avoid hills with excessively slippery or loose surfaces. Shift your weight to the uphill side of the ATV. Never attempt to turn the ATV around on any hill until you've mastered (on level ground) the turning technique outlined in this manual. Avoid crossing the side of a steep hill when possible.
- Always use proper procedures if you stall or roll backwards while climbing a hill. To avoid stalling, maintain a steady speed when climbing a hill. If you stall or roll backwards, follow the special procedure for braking described in this manual. Always dismount on the uphill side, or to either side if the ATV is pointed straight uphill. Turn the ATV around and remount following the procedure described in this manual.
- Always check for obstacles before operating in a new area. Never attempt to operate over large obstacles, such as rocks or fallen trees. Always follow proper procedures when operating over obstacles as described in this manual.
- Always be careful of skidding or sliding. On slippery surfaces like ice, travel slowly and use extra caution to reduce the chance of skidding or sliding out of control.
- Avoid operating the ATV through deep or fast-flowing water. If it's unavoidable, travel slowly, balance your weight carefully, avoid sudden movements, and maintain a slow and steady forward motion. Do not make sudden turns or stops, and do not make sudden throttle changes.

OPERATOR SAFETY

- Wet brakes may have reduced stopping ability. Test your brakes after leaving water. If necessary, apply them lightly several times while driving slowly to allow friction to dry out the pads.
- Always check for obstacles or people behind the ATV before operating in reverse. When it's safe to proceed in reverse, move slowly and avoid turning at sharp angles.
- Always use the size and type of tires specified for your ATV, and always maintain proper tire pressure.
- Never modify an ATV through improper installation or use of accessories.
- Never exceed the stated load capacity for your ATV. Cargo must be properly distributed and securely attached. Reduce speed and follow the instructions in this manual for carrying cargo or towing. Allow a greater distance for braking.
- Always remove the ignition key when the vehicle is not in use to prevent unauthorized use or accidental starting.
- Children or pets shall not be carried on the racks.
- Never touch running parts, such as wheels, drive shaft, etc.

FOR MORE INFORMATION ABOUT ATV SAFETY, PLEASE CONTACT YOUR DEALER.

OPERATOR SAFETY

WARNING

POTENTIAL HAZARD:

Operating this ATV without proper instruction.

WHAT CAN HAPPEN:

The risk of an accident is greatly increased if the operator does not know how to operate the ATV properly in different situations and on different types of terrain.

HOW TO AVOID THE HAZARD:

Beginning and inexperienced operators should complete a certified training course offered by a dealer.

Operators should regularly practice the skills learned in the course and the operating techniques described in the owner's manual.

WARNING

POTENTIAL HAZARD:

Failure to follow the age recommendations for this ATV.

WHAT CAN HAPPEN:

Severe injury and/or death could occur if a child under the minimum age recommendation operates an ATV. Even though a child may be within the recommended age group for operating some ATVs, he/she may not have the skills, abilities or judgment needed to operate an ATV safely and could be susceptible to accident or injury.

HOW TO AVOID THE HAZARD:

Operation is prohibited for anyone under 16 years of age.

OPERATOR SAFETY

⚠️ WARNING

POTENTIAL HAZARD:

Carrying a passenger on an ATV that is not designed for carrying a passenger.

WHAT CAN HAPPEN:

A passenger riding on the ATV could be ejected from the vehicle unexpectedly or make contact with moving components, both of which can result in severe injury or death.

HOW TO AVOID THE HAZARD:

Never allow a passenger on an ATV that is not designed for carrying a passenger.



OPERATOR SAFETY

⚠️ WARNING

POTENTIAL HAZARD:

Operation on paved surfaces such as sidewalks, trails parking lots, or public highways and streets.

WHAT CAN HAPPEN:

ATV tires are designed for off-road use. Driving on paved surfaces greatly affects how an ATV handles, which can result in loss of control and/or an accident.

HOW TO AVOID THE HAZARD:

Never drive on paved surfaces. If it is unavoidable, slow down and do not make sudden turning or braking maneuvers.

Never operate ATVs on public highways or streets if it is not allowed by law. Check local laws to determine if it is legal to do so.

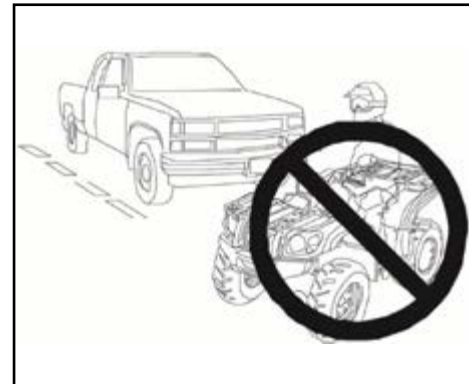

OPERATOR SAFETY

⚠️ WARNING

POTENTIAL HAZARD:

Operating this ATV without wearing an approved helmet, eye protection, and protective clothing.

WHAT CAN HAPPEN:

Operating an ATV without an approved helmet increases the risk of a severe head injury or death in the event of an accident. Operating without eye protection could result in an accident and could increase the chance of a severe eye injury in the event of an accident. Operating without protective clothing could increase the chance of a severe injury.

HOW TO AVOID THE HAZARD:

Always wear an approved helmet that fits properly. Always wear eye protection (goggles or face shield), gloves, long-sleeved shirt or jacket, and long pants.



OPERATOR SAFETY

⚠️ WARNING

POTENTIAL HAZARD:

Operating the ATV after consuming alcohol or drugs.

WHAT CAN HAPPEN:

Consumption of alcohol and/or drugs could seriously affect operator judgment. Reaction time may be slower and operator balance and perception could be affected. Consumption of alcohol and/or drugs before or while operating an ATV could result in an accident causing severe injury or death.

HOW TO AVOID THE HAZARD:

Never consume alcohol or drugs before or while operating an ATV.



OPERATOR SAFETY

⚠️ WARNING

POTENTIAL HAZARD:

Operating the ATV at excessive speeds.

WHAT CAN HAPPEN:

Excessive speed increases the operator's chance of losing control of the ATV, which can result in an accident.

HOW TO AVOID THE HAZARD:

Always operate the ATV at a speed that's proper for the terrain, visibility and operating conditions, and your experience.

⚠️ WARNING

POTENTIAL HAZARD:

Attempting wheelies, jumps and other stunts.

WHAT CAN HAPPEN:

Attempting stunts increases the chance of an accident, including an overturn.

HOW TO AVOID THE HAZARD:

Never attempt wheelies, jumps, or other stunts. Avoid exhibition driving.

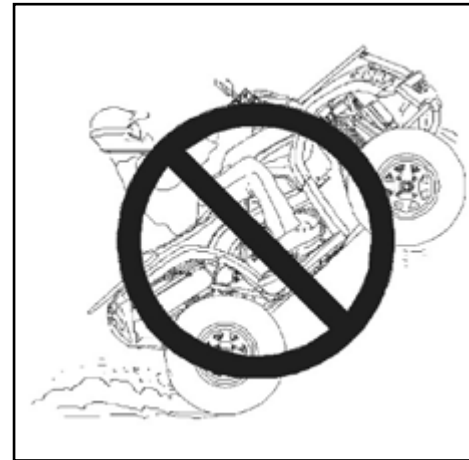

OPERATOR SAFETY

⚠WARNING

POTENTIAL HAZARD:

Failure to inspect the ATV before operating. Failure to properly maintain the ATV.

WHAT CAN HAPPEN:

Poor maintenance increases the possibility of an accident or equipment damage.

HOW TO AVOID THE HAZARD:

Always inspect your ATV before each use to make sure it's in safe operating condition.

Always follow the inspection and maintenance procedures and schedules described in the owner's manual.

⚠WARNING

POTENTIAL HAZARD:

Removing hands from the handlebars or feet from the footrests during operation.

WHAT CAN HAPPEN:

Removing even one hand or foot can reduce ability to control the vehicle or could cause loss of balance and ejection from the ATV.

If the operator's foot is not firmly planted on the footrest, it could come into contact with the rear wheels and lead to an accident or injury.

HOW TO AVOID THE HAZARD:

Always keep both hands on the handlebars and both feet on the footrests of the ATV during operation.

OPERATOR SAFETY

⚠️ WARNING

POTENTIAL HAZARD:

Failure to use extra caution when operating the ATV on unfamiliar terrain.

WHAT CAN HAPPEN:

Unfamiliar terrain may contain hidden rocks, bumps, or holes that could cause loss of control or overturn.

HOW TO AVOID THE HAZARD:

Travel slowly and use extra caution when operating on unfamiliar terrain. Always be alert to changing terrain conditions.



OPERATOR SAFETY

⚠️ WARNING

POTENTIAL HAZARD:

Failure to use extra caution when operating on excessively rough, slippery or loose terrain.

WHAT CAN HAPPEN:

Operating on excessively rough, slippery or loose terrain could cause loss of traction or loss of control, which could result in an accident or overturn.

HOW TO AVOID THE HAZARD:

Do not operate on excessively rough, slippery or loose terrain until you've learned and practiced the skills necessary to control the ATV on such terrain. Always use extra caution on rough, slippery or loose terrain.



OPERATOR SAFETY

WARNING

POTENTIAL HAZARD:

Turning improperly.

WHAT CAN HAPPEN:

Improper turns could cause loss of control and lead to a collision or overturn.

HOW TO AVOID THE HAZARD:

Always follow proper procedures for turning as described in the owner's manual. Practice turning at slow speeds before attempting to turn at faster speeds. Never turn at excessive speed.

OPERATOR SAFETY

⚠️ WARNING

POTENTIAL HAZARD:

Climbing excessively steep hills or climbing hills improperly.

WHAT CAN HAPPEN:

Improper hill climbing could cause loss of control or overturn.

HOW TO AVOID THE HAZARD:

Never operate on hills too steep for the ATV or for your abilities. Practice on smaller hills before attempting large hills. Always check the terrain carefully before ascending any hill. Never climb hills with excessively slippery or loose surfaces. Shift your weight forward. Never open the throttle suddenly while traveling uphill. The ATV could flip over backwards. Never go over the top of any hill at high speed. An obstacle, a sharp drop, or another vehicle or person could be on the other side of the hill.



OPERATOR SAFETY

⚠️ WARNING

POTENTIAL HAZARD:

Traveling down excessively steep hills.

WHAT CAN HAPPEN:

Improper downhill travel could cause loss of control or overturn.

HOW TO AVOID THE HAZARD:

Never operate on hills too steep for the ATV or for your abilities. Practice on smaller hills before attempting large hills. Always check the terrain carefully before attempting any hill. Never descend hills with excessively slippery or loose surfaces.

NOTE

A special driving and braking technique is required while traveling downhill. Always check the terrain carefully before descending a hill. Shift your weight backward. Never travel down a hill at high speed. Avoid traveling down a hill at an angle, which would cause the vehicle to lean sharply to one side. Travel straight down the hill when possible.



OPERATOR SAFETY

⚠️ WARNING

POTENTIAL HAZARD:

Improperly crossing hills and turning on hills.

WHAT CAN HAPPEN:

Improperly crossing or turning on hills could cause loss of control or overturn.

HOW TO AVOID THE HAZARD:

Never attempt to turn the ATV around on any hill until you've mastered the turning technique on level ground as described in the owner's manual.

Use extra caution when turning on any hill. Avoid crossing the side of a steep hill.

WHEN CROSSING THE SIDE OF A HILL:

Always follow proper procedures as described in the owner's manual. Avoid hills with excessively slippery or loose surfaces. Shift your weight to the uphill side of the ATV.



OPERATOR SAFETY

⚠️ WARNING

POTENTIAL HAZARD:

Stalling, rolling backwards or improperly dismounting while climbing a hill.

WHAT CAN HAPPEN:

The vehicle could overturn.

HOW TO AVOID THE HAZARD:

Maintain a steady speed when climbing a hill.

IF ALL FORWARD SPEED IS LOST:

Close the throttle. Keep your weight uphill. Apply the front brake. When fully stopped, apply the foot brake as well, then shift the gear selector to the park position.

IF THE ATV BEGINS ROLLING:

Keep weight uphill. Never apply engine power. Never apply the foot brake while rolling backwards. Apply the front brake. When fully stopped, apply the foot brake and shift the gear selector to the parking position. Dismount on uphill side, or to either side if ATV is pointed straight uphill.

Turn the ATV around and remount, following the procedure described in the owner's manual.



OPERATOR SAFETY

WARNING

POTENTIAL HAZARD:

Improperly operating over obstacles.

WHAT CAN HAPPEN:

Operating over obstacles could cause loss of control or overturn.

HOW TO AVOID THE HAZARD:

Before operating in a new area, check for obstacles. Avoid operating over large obstacles such as rocks and fallen trees when possible. If unavoidable, use extreme caution and always follow proper procedures as outlined in the owner's manual.

OPERATOR SAFETY

⚠️ WARNING

POTENTIAL HAZARD:

Skidding or sliding.

WHAT CAN HAPPEN:

Skidding or sliding can cause loss of control. If the tires regain traction unexpectedly, the ATV could overturn.

HOW TO AVOID THE HAZARD:

On slippery surfaces such as ice, travel slowly and use extra caution to reduce the chance of skidding or sliding out of control.

⚠️ WARNING

POTENTIAL HAZARD:

Overloading the ATV or carrying/towing cargo improperly.

WHAT CAN HAPPEN:

Overloading and towing can cause changes in vehicle handling, which could lead to loss of control or an accident.

HOW TO AVOID THE HAZARD:

Never exceed the stated load capacity for this ATV.

Cargo should be properly distributed and securely attached. Reduce speed when carrying cargo or pulling a trailer. Allow a greater distance for braking. Always follow the instructions in the owner's manual for carrying cargo or pulling a trailer.

OPERATOR SAFETY

WARNING

POTENTIAL HAZARD:

Operation of the ATV through deep or fast-flowing water.

WHAT CAN HAPPEN:

The tires may float, causing loss of traction and loss of control, which can lead to an accident or overturn.

HOW TO AVOID THE HAZARD:

Avoid operating the ATV through deep or fast-flowing water. If it is unavoidable to enter water that exceeds the recommended maximum depth, travel slowly, balance your weight carefully, avoid sudden movements, and maintain a slow and steady forward motion. Do not make sudden turns or stops, and do not make sudden throttle changes. Wet brakes may have reduced stopping ability. Always test the brakes after leaving the water. If necessary, apply brakes several times to dry out the pads.

OPERATOR SAFETY

⚠️ WARNING

POTENTIAL HAZARD:

Improperly operating in reverse.

WHAT CAN HAPPEN:

The ATV could collide with an obstacle or person, resulting in severe injury.

HOW TO AVOID THE HAZARD:

Before shifting into reverse gear, always check for obstacles or people behind the ATV. When it's safe to proceed, back slowly.

⚠️ WARNING

POTENTIAL HAZARD:

Operating this ATV with improper tires, or with improper or uneven tire pressure.

WHAT CAN HAPPEN:

Use of improper tires, or operation of the ATV with improper or uneven tire pressure, could cause loss of control or an accident.

HOW TO AVOID THE HAZARD:

Always use the size and type of tires specified in the owner's manual for the ATV. Always maintain proper tire pressure.

OPERATOR SAFETY

WARNING

POTENTIAL HAZARD:

Operating the ATV with improper modifications.

WHAT CAN HAPPEN:

Improper installation of accessories or modification of the ATV may cause changes in handling which could lead to an accident.

HOW TO AVOID THE HAZARD:

Never modify the ATV through improper installation or use of accessories. All parts and accessories added to the vehicle must be genuine parts or equivalent components designed for use on this ATV and should be installed and used according to approved instructions. Consult your dealer for more information.

OPERATOR SAFETY

WARNING

POTENTIAL HAZARD:

Operating on frozen bodies of water.

WHAT CAN HAPPEN:

Severe injury or death can result if the ATV and/or the operator fall through the ice.

HOW TO AVOID THE HAZARD:

Never operate the ATV on a frozen body of water.

OPERATOR SAFETY

WARNING

Leaving the keys in the ignition can lead to unauthorized use of the vehicle, resulting in serious injury or death. Always remove the ignition key when the vehicle is not in use.

WARNING

After any overturn or accident, have a qualified service dealer inspect the entire vehicle for possible damage, including (but not limited to) brakes, throttle and steering systems.

WARNING

Safe operation of this rider-active vehicle requires good judgment and physical skills. Persons with cognitive or physical disabilities who operate this vehicle have an increased risk of overturn and loss of control, which could result in severe injury or death.

WARNING

Exhaust system components are very hot during and after use of the vehicle. Hot components can cause serious burns and fire. Do not touch hot exhaust system components. Always keep combustible materials away from the exhaust system. Use caution when traveling through tall grass, especially dry grass.

OPERATOR SAFETY

Safe Riding Gear

Always wear clothing suited to the type of riding. ATV riding requires special protective clothing for comfort and to reduce the chance of injury:

1 **Helmet**

Your helmet is the most important piece of protective gear for safe riding. An approved helmet can prevent a severe head injury.

2 **Eye protection**

Do not depend on sunglasses for proper eye protection. A pair of goggles or a helmet face shield offers the best protection for your eyes. They should be kept clean and be a shatterproof design.

3 **Gloves**

Off-road style gloves with knuckle pads are the best for comfort and protection.

4 **Boots**

The best footwear is a pair of strong over-the-calf boots with heels, like moto-cross boots.

5 **Clothing**

Always wear long sleeves and long pants to protect arms and legs. Riding pants with kneepads and a jersey with shoulder pads provide the best protection.

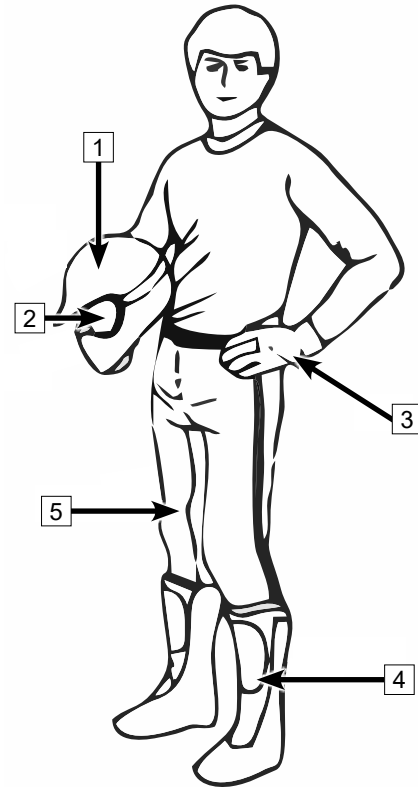

SAFETY DECALS & LOCATIONS

Safety Decals and Locations

Warning decals have been placed on the ATV for your protection. Read and follow the instructions on each decal carefully. If a decal becomes illegible or comes off, contact your dealer to purchase a replacement.

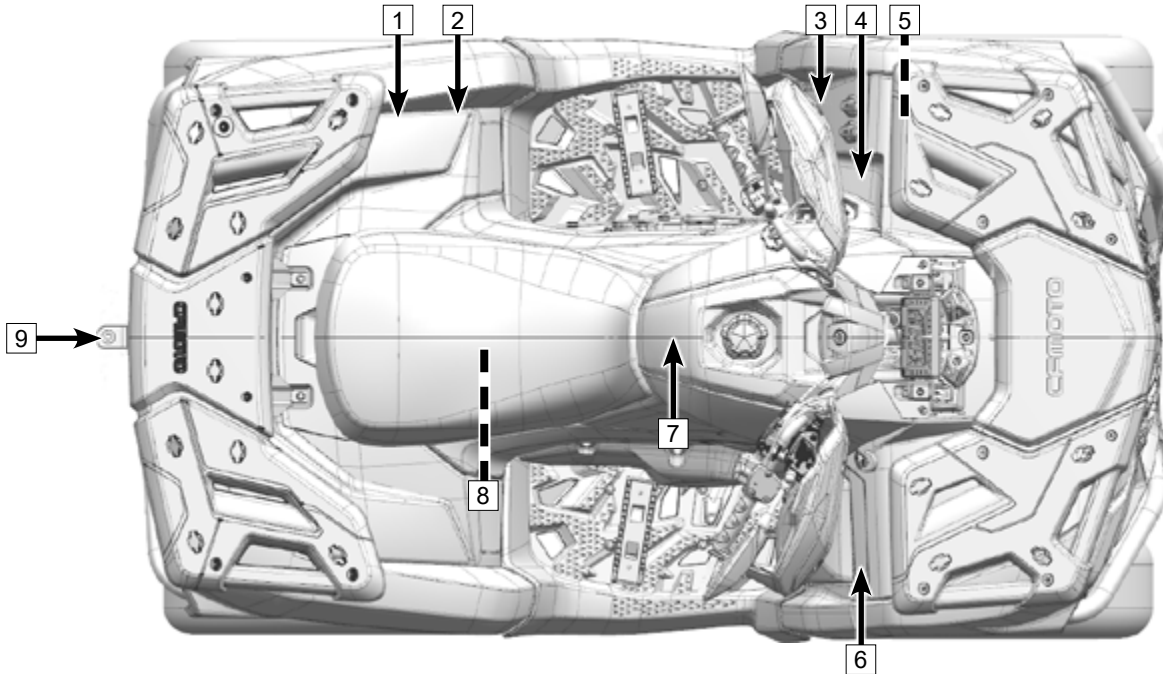

SAFETY DECALS & LOCATIONS

1

TYPE I

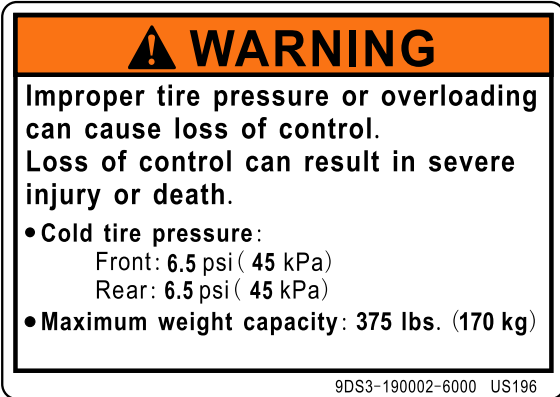

TYPE II

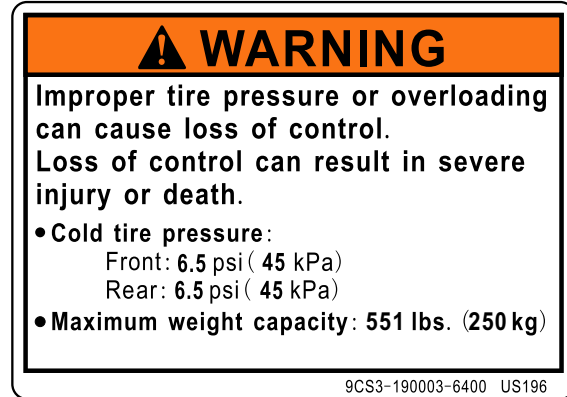

SAFETY DECALS & LOCATIONS

2

TYPE I

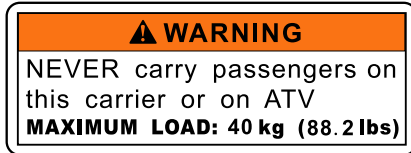

TYPE II



4

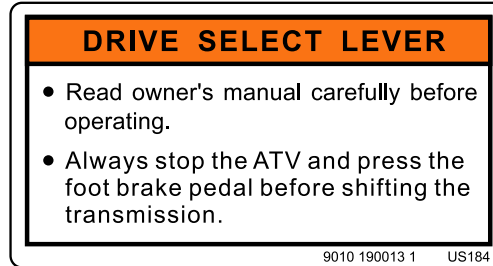

3



SAFETY DECALS & LOCATIONS

TYPE I

3

▲ **WARNING**

Improper ATV use can result in SEVERE INJURY or DEATH.



ALWAYS USE AN APPROVED HELMET AND PROTECTIVE GEAR



NEVER USE ON PUBLIC ROADS



NEVER CARRY PASSENGERS



NEVER USE WITH DRUGS OR ALCOHOL

NEVER operate :

- without proper training or instruction.
- at speeds too fast for your skills or the conditions.
- on public roads - a collision can occur with another vehicle.
- with a passenger - passengers affect balance and steering and increase risk of losing control.

ALWAYS :

- use proper riding techniques to avoid vehicle overturns on hills and rough terrain and in turns.
- avoid paved surfaces - pavement may seriously affect handling and control.

LOCATE AND READ OWNER'S MANUAL.
FOLLOW ALL INSTRUCTIONS AND WARNINGS.

9DS3-190004-6000 US196

TYPE II

▲ **WARNING**

Improper use can result in SEVERE INJURY or DEATH



ALWAYS USE AN APPROVED HELMET AND PROTECTIVE GEAR FOR DRIVER AND PASSENGER



NEVER USE ON PUBLIC ROADS



NEVER CARRY MORE THAN 1 PASSENGER



NEVER USE WITH DRUGS OR ALCOHOL

NEVER operate :

- without proper ATV training or instruction.
- at speeds too fast for your skills or the conditions.
- on public roads - a collision can occur with another vehicle.
- with a passenger unless passenger seat is securely in place.

THE OPERATOR MUST ALWAYS :

- use proper riding techniques to avoid overturns on hills and rough terrain and in turns
- avoid paved surfaces - pavement may seriously affect handling and control
- reduce speed and use extra caution at all times when carrying a passenger - dismount passenger when conditions require
- make sure passenger reads and understands this label and passenger safety label

LOCATE AND READ OPERATOR'S MANUAL.
FOLLOW ALL INSTRUCTIONS AND WARNINGS

9CS3-190004-6400 US196

SAFETY DECALS & LOCATIONS

TYPE I

3

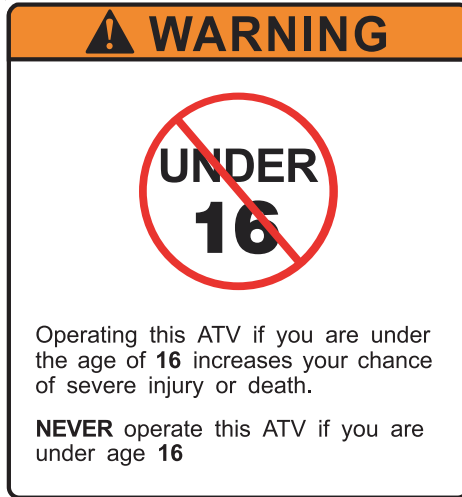

TYPE II

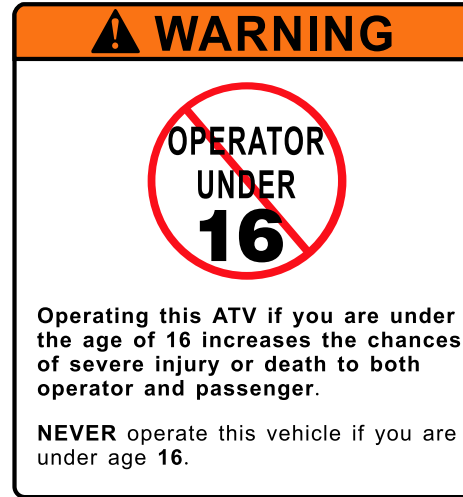

SAFETY DECALS & LOCATIONS

TYPE I

3



TYPE II



SAFETY DECALS & LOCATIONS

TYPE I

5



TYPE II



6

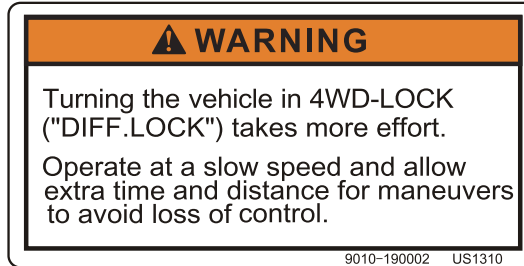

7



SAFETY DECALS & LOCATIONS

8

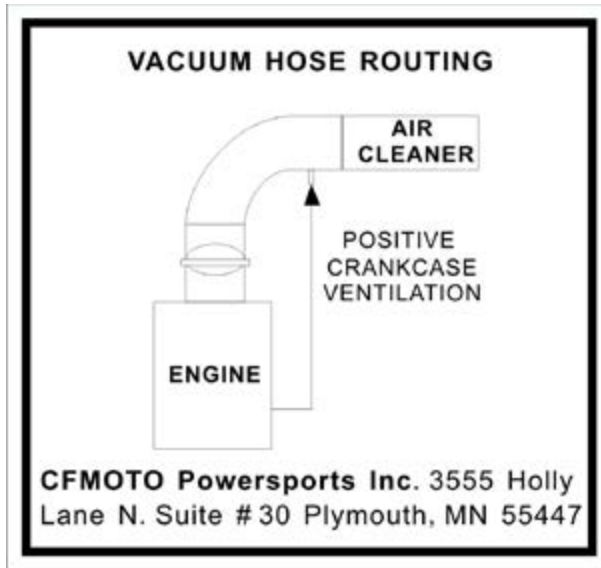

9

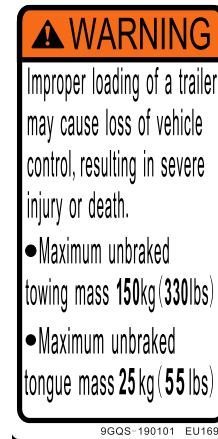

FEATURES & CONTROLS

Features & Controls

Left Hand Controls

1 Override Button

The engine is normally limited when operating in 4WD-LOCK

If conditions require more engine power in 4WD-LOCK:

- Release the throttle and press the button to override the speed limiting function. While this button is depressed, the override indicator light will come on.
- Releasing the button restores the speed limiting function.

WARNING

Pressing the override button while the throttle is open can cause loss of control, resulting in severe injury or death. Always release the throttle before pressing the override button.

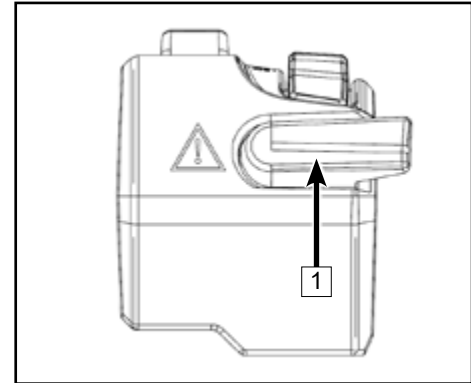

FEATURES & CONTROLS

2 Headlight Switch

The headlight switch consists of 4 positions:

: When the switch is at this position, Hi beam, front position light, tail light, and license plate light are on.

: When the switch is at this position, Lo beam, front position light, tail light, and license plate light are on.

OFF: When the switch is at this position, only daytime running light is on and all other lights are off .

: When the switch is at this position, daytime running light, tail light, and front position light are on.

3 Turn Switch (If equipped)

Move the switch to  for left turn signal indicator on.

Move the switch to  for right turn signal indicator on.

4 Hazard Switch (If equipped)

Press the button . Front turn lights, rear turn lights and turn signal indicators on dashboard flash.

CAUTION

Do not use the headlights with the engine turned off for more than 15 minutes. The battery may discharge to the point that the starter motor will not operate properly. If this should happen, remove the battery and recharge it.

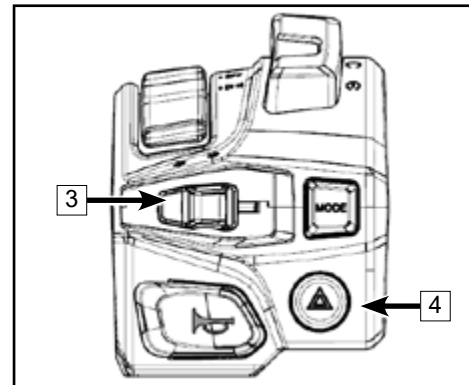
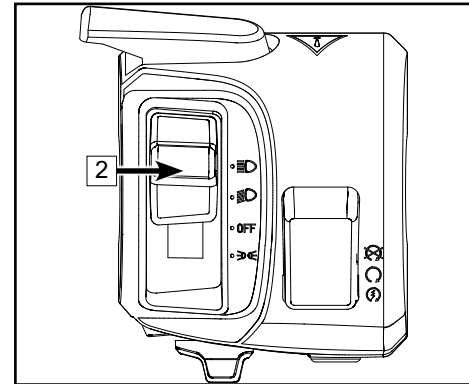

FEATURES & CONTROLS

5 Horn Button

 Press the button, the horn will sound.

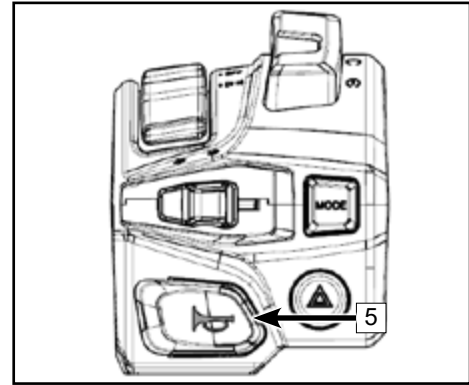

6 Engine Stop Switch

When the switch is at  position, the engine shuts off.

When the switch is at  position, the engine can be started.

7 Starter Switch

When the main switch is turned to ON, and the engine stop switch is at , push this button to start the engine.

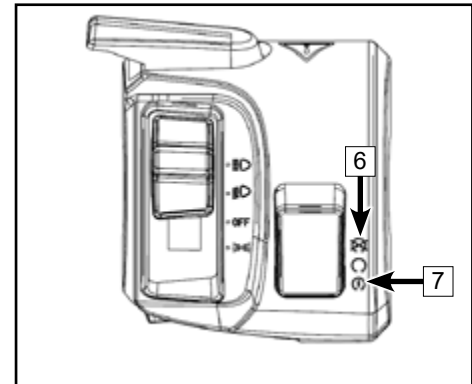

FEATURES & CONTROLS

8 Mode Button

When the MODE button is pressed, it will hold in or release out, and a mode shift will be completed:

The following modes display on the dashboard, depending on the mode button position:

NORMAL	When the button is pressed and released out, the vehicle is in 'NORMAL' mode. The dashboard display will also shift to 'NORMAL' mode. The vehicle will have a less aggressive throttle response for smooth starts and is intended for flat trails, hard pack ground, etc. Use for light-duty riding. NOTE: Do not use this mode for driving situations that place high load on the CVT belt. Damage may occur.
WORK	When the button is pressed in, the vehicle is in 'WORK' mode. The dashboard display will also shift to 'WORK' mode. The vehicle will have a faster throttle response. NOTE: Use this mode for work loads, complex terrain or trails, and other driving situations that can place a high load on the CVT belt.

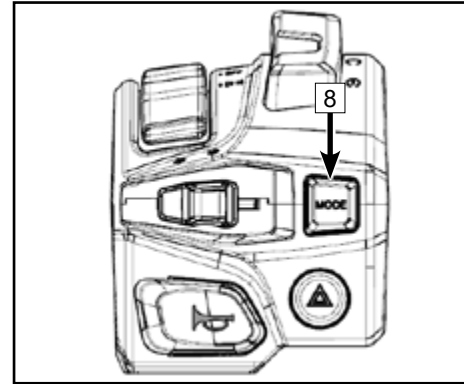

FEATURES & CONTROLS

Right Hand Controls

1 Front Brake

The front brake lever is located on the right handlebar and controls only the front brakes. Pull it toward the handlebar to apply the front brake. When squeezed, the lever or pedal should feel firm. Any sponginess would indicate a possible fluid leak or low master cylinder fluid level, which must be corrected before riding. Contact your dealer for proper diagnosis and repairs.

2 Front Brake Fluid Reservoir And Level Indicator

Check the front brake master cylinder fluid level before each use of the ATV. The front brake master cylinder is located on the right handlebar. The fluid level can be viewed through the indicator window on the side of the master cylinder. If the fluid level is lower than the “lower” mark, refill with brake fluid as necessary.

WARNING

An over-full master cylinder may cause brake drag or brake lock-up, which could result in serious injury or death. Maintain brake fluid at the recommended level. Do not overfill.

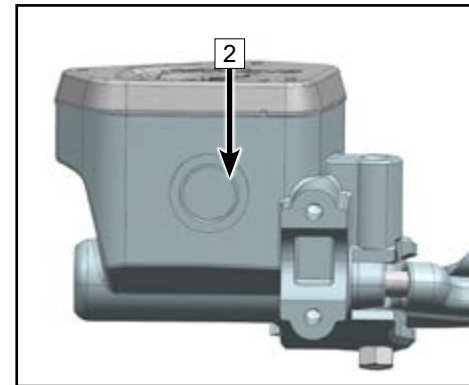
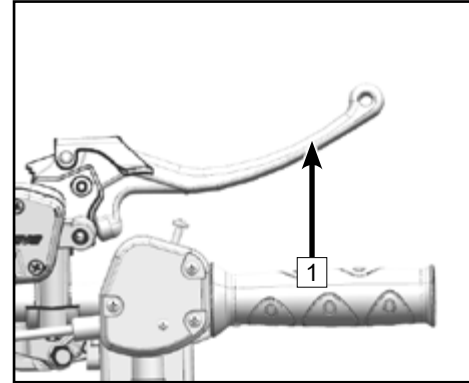

FEATURES & CONTROLS

3 2WD / 4WD System Switch

This vehicle is equipped with on-command “2-WD”/”4-WD” and ”4-WD/F-LOCK” switches. Activate these switches according to the traction required for different driving conditions.

A: Switches two wheel drive (2-WD) and four wheel drive (4-WD).

B: Switches four wheel drive (4-WD) and four wheel drive lock (F-lock).

WARNING

The vehicle should be stopped before applying or releasing the function of 2WD/4WD/F-lock. Applying or releasing drive modes while the vehicle is in motion can lead to component damage.

“F-lock” Operation

In “F-lock” mode, both front axles are locked together and rotate at the same speed to provide maximum front wheel traction. The steering will require more force for turning. The drive mode indicator on the dashboard will flash until front differential lock is engaged.

Riding before the differential is properly engaged (e.g. when the indicator light is flashing) will cause the engine speed to be limited until engagement is complete.

Maximum traveling speed in F-lock is limited to 22 mph (30 km/h). If conditions require full engine power to be available, press the override switch on the left control to disable speed limiting.

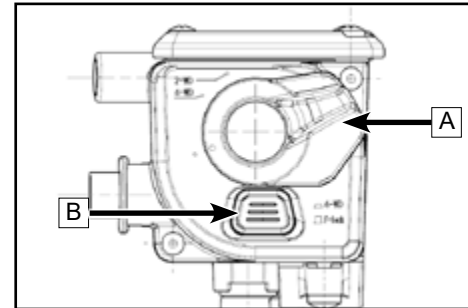

Vehicles without rear differential

FEATURES & CONTROLS

C(Select Markets): Switches rear wheel drive differential and rear wheel drive lock. This feature only applies to vehicles that are equipped with R-WD/R-Lock function.

R-lock Operation

In “R-lock” mode, both rear axles are locked together and rotate at the same speed to provide maximum rear wheel traction. Turning effort and tire wear will be increased on hard surfaces. The drive mode indicator on the dashboard will flash until the rear differential lock is engaged.

Riding before the differential is properly engaged (e.g. when the indicator light is flashing) will cause the engine speed to be limited until engagement is complete.

4 Throttle Lever

Once the engine is running, movement of the throttle lever will increase the engine speed. Regulate the speed of the machine by varying the throttle position. Because the throttle is spring loaded, the machine will decelerate, and the engine will return to an idle any time the hand is removed from the throttle lever. Before starting the engine, check the throttle to be sure it is operating smoothly. Make sure it returns to the idle position as soon as the lever is released.

⚠ CAUTION

Check the operation of the throttle lever before you start the engine. If it does not work smoothly, check for the cause. Correct the problem before riding the ATV. Consult your dealer if you cannot find or solve the problem.

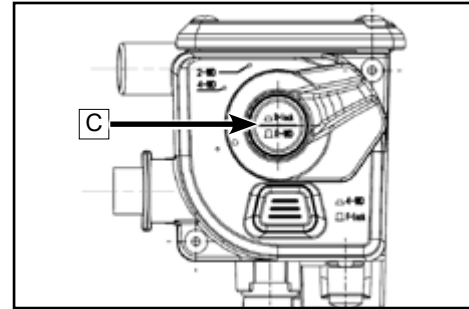

Vehicles with rear differential

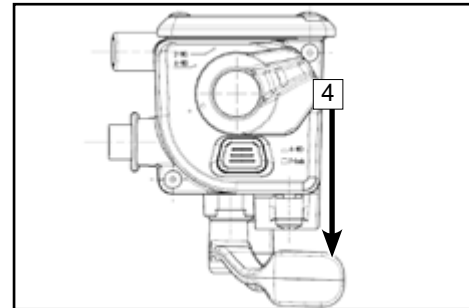

FEATURES & CONTROLS

5 Parking Brake

Hydraulic parking brake is mounted on the right hand brake. To apply parking brake, grasp tightly the right hand brake first, and press foot brake at the same time, then press the hydraulic parking brake 5 by left hand.

CAUTION

Do not to rely only on the hydraulic parking brake when parked on an incline. For additional safety, shift the transmission to the park position and block the wheels to prevent vehicle rolling.

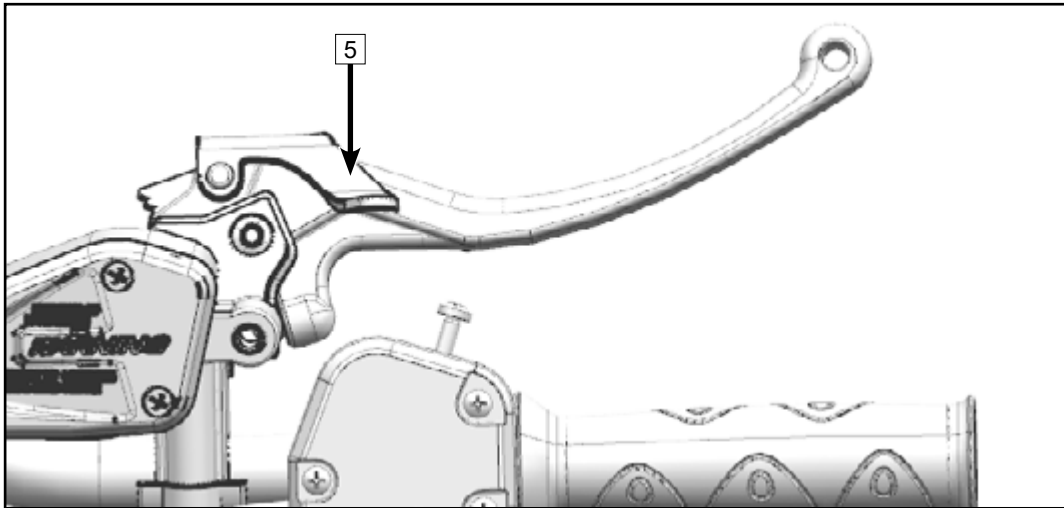

FEATURES & CONTROLS

6 Mechanical Speed Limiter

A mechanical speed limiter keeps the throttle from fully opening, even when the throttle lever is pushed to maximum travel. Turning in the screw limits the throttle lever travel, which reduces the maximum engine power available and decreases the maximum speed of the ATV.

NOTE

Your ATV is set for maximum throttle opening from the factory.

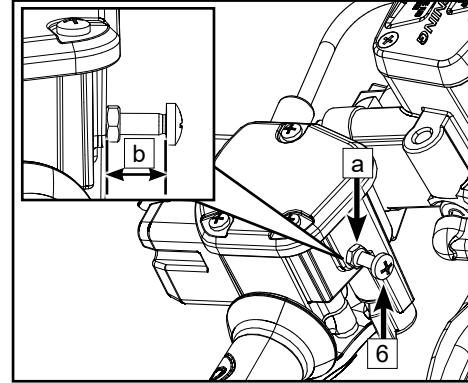

CAUTION

Always loosen the locking nut **a** before each adjustment. Do not turn the adjusting screw out more than **b** 12 mm (0.47 in). Always make sure the throttle lever free play remains adjusted to 3 mm ~ 5 mm (0.12 in ~ 0.20 in). Tighten the locking nut when the adjustment is completed.

FEATURES & CONTROLS

Foot Brake

The foot brake pedal **1** is located on the right side floor board of the vehicle. Pushing down on the pedal applies the front and rear brakes at the same time.

When applied, the pedal should feel firm. A soft brake pedal would indicate a possible fluid leak or low master cylinder fluid level, which must be corrected before riding. Contact your dealer for proper diagnosis and repairs.

⚠ WARNING

Operating the ATV with a spongy brake lever or pedal can result in loss of control, which could cause an accident. Never operate with a spongy-feeling brake lever or pedal.

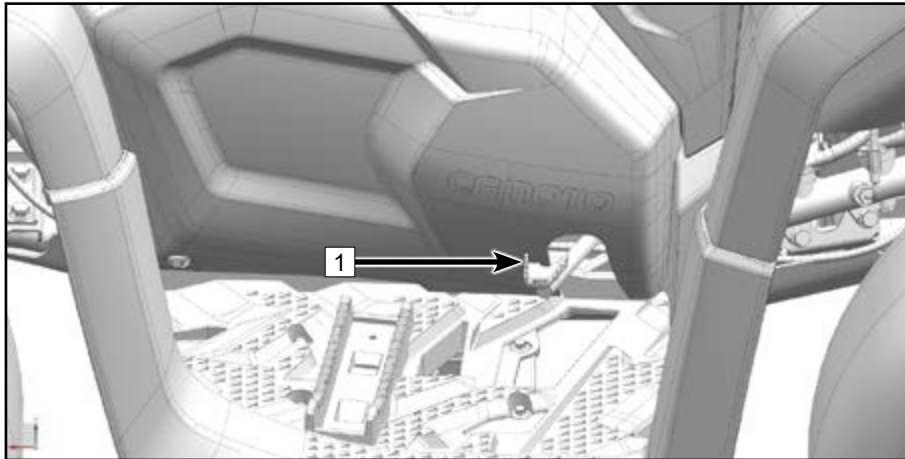

FEATURES & CONTROLS

Foot Brake Reservoir Fluid Level Check

NOTE

Remove the front access cover and then check the fluid level.

When checking the fluid level, the ATV must be on level ground. If fluid level is lower than the “lower” mark **2**, add DOT4 brake fluid. Don't overfill.

WARNING

Never store or use a partial bottle of brake fluid. Brake fluid is hygroscopic, meaning it rapidly absorbs moisture from the air. The moisture causes the drop of boiling temperature of the brake fluid, which can lead to early brake fade and the possibility of accident or severe injury. After opening a bottle of brake fluid, always discard any unused portion.

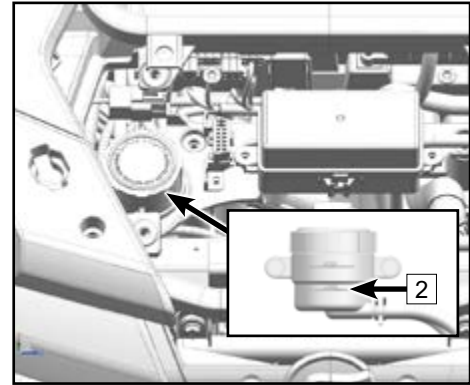

FEATURES & CONTROLS

Fuel Tank

Fuel tank cap is located at the front of the vehicle. Open the fuel tank cap **1** to fill fuel.

Fuel Minimum Octane Rating

The recommended fuel for your ATV is minimum 89 Octane unleaded (maximum 10% ethanol is allowed). Non-oxygenated (ethanol-free) fuel is recommended for best performance in all conditions.

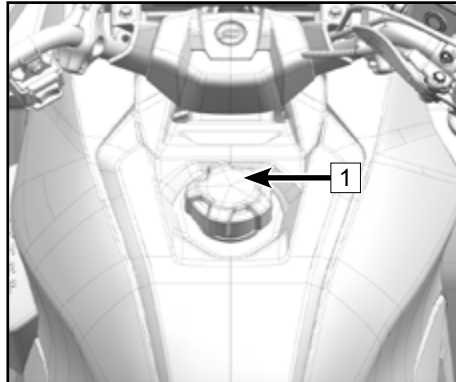

FEATURES & CONTROLS

Fuel Safety

 **WARNING**

Gasoline is highly flammable and explosive under certain conditions.

- Always exercise extreme caution whenever handling gasoline.
- Always refuel with the engine stopped, and outdoors or in a well ventilated area.
- Never carry a plastic container with gasoline in the racks while riding. Static electricity between the rack and container could cause a spark.
- Do not smoke or allow open flames or sparks in or near the area where refueling is performed, or where gasoline is stored.
- Do not overfill the tank. Do not fill the tank neck.
- If gasoline spills on your skin or clothing, immediately wash it off with soap and water and change clothing.
- Never start the engine or let it run in an enclosed area. Engine exhaust fumes are poisonous and can cause loss of consciousness or death in a short time.

 **WARNING**

The engine exhaust from this product contains chemicals known to cause cancer, birth defects or other reproductive harm. Operate this vehicle only outdoors or in well-ventilated areas.

FEATURES & CONTROLS

Transmission Gear Selector

The transmission gear selector 1 is located on the left side of the vehicle.

CAUTION

Always stop the ATV and press the foot brake pedal before shifting the transmission. Shifting gears with the engine speed above idle or while the vehicle is moving could cause transmission damage.

To change gears, stop the vehicle, and with the engine idling, move the lever to the desired gear. Whenever the ATV is left unattended, always place the transmission in the PARK position. Maintaining shift linkage adjustment is important to assure proper transmission function. See your dealer if you experience any shifting problems.

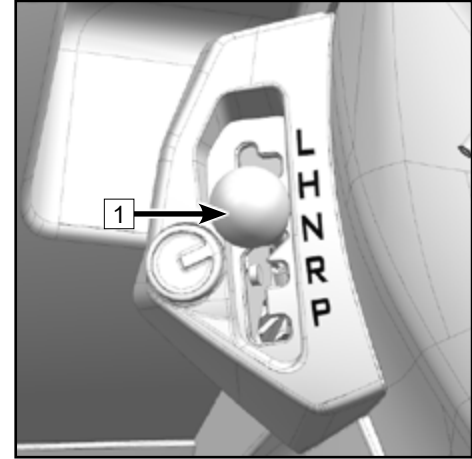

L: Low Gear
H: High Gear
N: Neutral
R: Reverse
P: Park

FEATURES & CONTROLS

Parking

To park the ATV, stop the engine, press the foot brake, and shift the gear selector Lever **1** into the park position.

⚠ CAUTION

When shifting the transmission in PARK, always push the brake pedal. Shake the vehicle forward and backward to verify that park is engaged.

Do not transport the vehicle with the gear selector in the PARK position. Damage to the transmission may result.

Important Safeguards

- Never depend on the parking feature alone if the ATV is parked on a hill. Always block the wheels on the downhill side of the ATV to prevent rolling. It is recommended to park the ATV on level ground.

Gear selector lock

Gear selector lock **2** is used for locking the transmission to prevent the vehicle from theft.

When the vehicle needs to be left for long time or stopped outside, shift the gear selector **1** in P gear and lock the transmission by the gear selector lock **2** to prevent theft.

Put the gear on parking position, turn the key 180° by clockwise, then the gear selector lock will be locked.

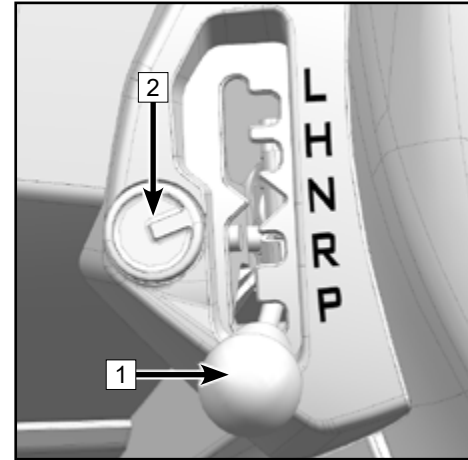

FEATURES & CONTROLS

CVT System

This vehicle has a Continuously Variable Transmission (CVT) system that utilizes a belt and clutch pulleys to automatically vary transmission ratios, allowing infinite variability between the highest and lowest vehicle speeds with no discrete steps or shifts.

The CVT consists of a primary clutch [1], which is an advanced form of centrifugal clutch that is mounted to the engine crankshaft [A]. The primary clutch also contains a one-way bearing that creates an engine braking feature to slow the vehicle without having to use the hand or foot brake.

The secondary clutch [2] is mounted to the input shaft of the transmission [B] and serves two functions: As a “slave” pulley to the primary clutch, and to provide a torque sensing element. The drive belt [3] is a heavy duty V-belt that connects the engine and transmission pulleys.

A CVT housing and cover encloses the clutches and belt assembly. It has inlet and outlet cooling ducts that route air to cool the components, and they should be inspected. The CVT components do not contain any user maintenance items. Contact your dealer for service.

NOTE:

To extend belt life, use low forward gear in heavy pulling situations and when operating at less than 7 miles per hour (11 kilometers per hour) for extended periods of time. If towing the vehicle is necessary, shift the transmission into neutral for better mobility and to prevent damage to the belt.

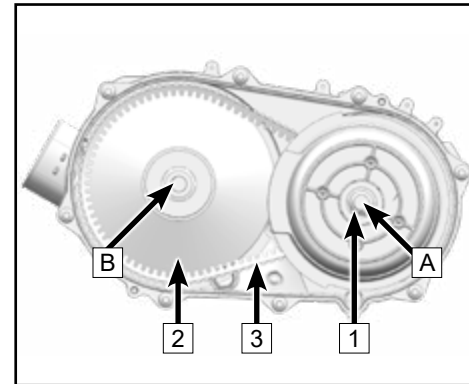

FEATURES & CONTROLS

Engine Braking System (EBS)

This vehicle is equipped with an engine braking system. The CVT primary clutch mounted to the engine crankshaft contains a one-way bearing that creates engine braking, which occurs when the throttle is completely closed, the engine is below the primary clutch engagement RPM, and the vehicle is at speed. It uses the engine's compression/resistive force to slow the over-driving transmission speed via the CVT drive belt, thereby slowing the entire vehicle gradually.

Engine braking is always active, and offers the most benefit when:

Used in conjunction with 4WD and 4WD Diff-Lock Modes.

Descending steep or slippery hills.

Descending rocky downhill terrain.

Slowing while towing heavy loads.

Assisting normal brake system application.

EBS is not a substitute for the vehicle brake system, although increased brake pad and disc life are realized when EBS assists normal brake system operation. The EBS is non-adjustable, and does not contain any user maintenance items. Contact your dealer for service.

FEATURES & CONTROLS

Avoiding CVT drive belt and component problems

CVT clutch and belt life can be dramatically extended by avoiding these common operating mistakes:

CVT Fail Reason	How To Avoid CVT Failure
Attempting to load the vehicle onto a truck bed or tall trailer in high gear.	Shift transmission to low gear during loading of the ATV to prevent belt burning.
Starting out on a steep incline in high gear.	When starting out on an incline, use low gear or dismount the ATV (after first applying the park brake) and perform the K-turn.
Constant driving at low RPM, driving at just above clutch engagement RPM, or at low speed (approximately 3 mph ~ 6 mph [5 km/h ~10 km/h]) in high gear.	Low gear is highly recommended for cooler CVT operating temperatures and longer component life. Drive at a higher speed or use low gear more frequently.
Insufficient warm-up of CVT exposed to low ambient temperatures.	Warm the engine before driving, the CVT drive belt will become more flexible and prevent belt burning.
Slow and easy CVT clutch engagement.	Use the throttle with purpose and effectively for efficient CVT clutch engagement.
Towing/pushing at low RPM/low ground speed.	Use low gear only.
Utility use/plowing snow, dirt, etc.	Use low gear only.
Heavy vehicle load operating at low speed	Use low gear only.

FEATURES & CONTROLS

CVT Fail Reason	How To Avoid CVT Failure
Stuck in mud or snow.	Shift the transmission to low gear, and carefully use fast, aggressive throttle application to engage clutch. WARNING: Excessive throttle may cause loss of control and vehicle overturn.
Climbing over large objects from a stopped position.	Shift the transmission to low gear, and carefully use fast, brief, aggressive throttle application to engage clutch. Excessive throttle may cause loss of control and vehicle overturn.
Belt slipping from water or snow ingestion into the CVT system.	Drain the water from the CVT housing and dry the CVT if possible, or contact your dealer.
Overheating of the CVT components causes malfunction.	Contact your dealer for inspection and repair of the CVT components.

FEATURES & CONTROLS

Vehicle Features

Main Switch 1

The functions of the main key switch positions are as follows:

⌚ : All electrical circuits are switched on. The engine can be started at this position. The key cannot be removed in this position.

⊗ : All electrical circuits are switched off. The key can be removed in this position.

The 'P' position has no function.

NOTE

Remove and store the spare key in a safe place. Your key can be duplicated only by mating a key blank with one of your existing keys. If both keys are lost, the complete switch assembly must be replaced.

Power Socket and USB Outlet 2

Auxiliary 12Vdc power and USB outlets are provided on the left side front fender area for operating accessories such as hand held spot lights and charging electronic devices. Please consult with your dealer on the use of powered accessories with your vehicle.

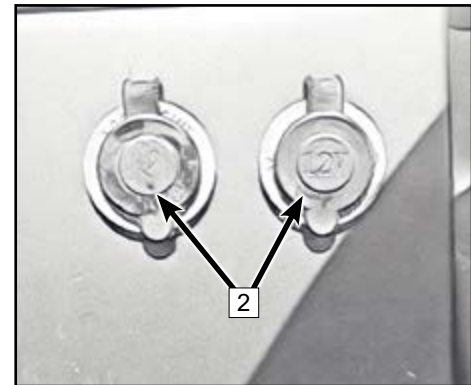
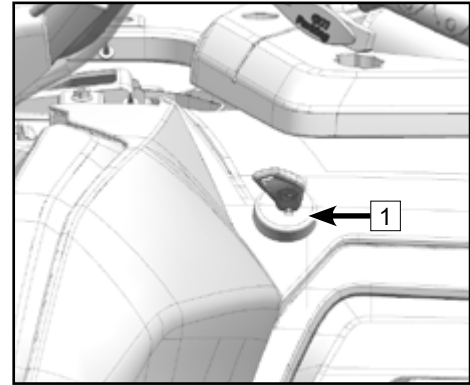

FEATURES & CONTROLS

Front Storage Box / Rear Storage Box

This vehicle is equipped with storage boxes on the front right side and the rear position.

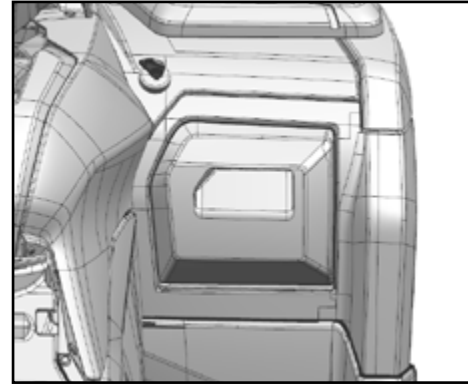

FEATURES & CONTROLS

Trailer Power Socket (If equipped) 1

Depending on market configuration, this vehicle is equipped with a 7-pin trailer power socket, located at the back of the vehicle. The socket wires are configured to the standard shown in the image provided. An accessory trailer power kit is required for vehicles that are not equipped with a 7-pin socket. Contact your dealer for more information.

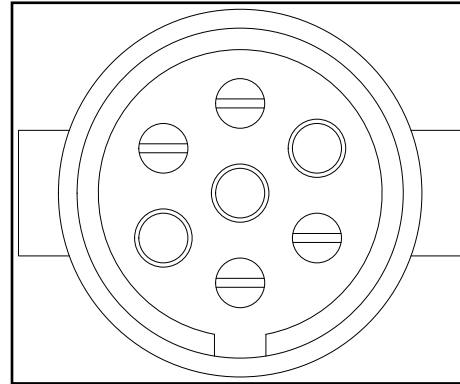
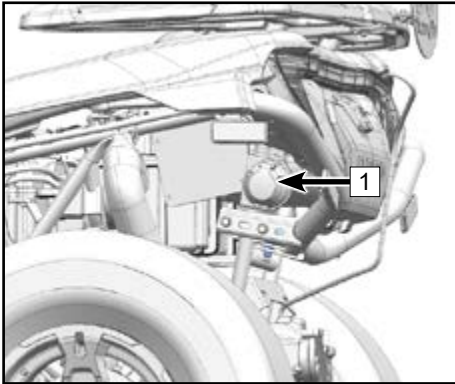

FEATURES & CONTROLS

Telematics BOX (T-BOX) (If equipped) - 1

CFMOTO vehicles are equipped with an intelligent vehicle terminal T-Box 1. It build the communication bridge between the owner and vehicle through CFMOTO RIED APP. Please search and download CFMOTO RIED APP.

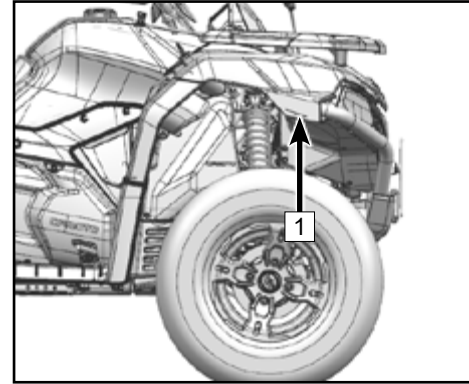

Tool Kit

Tool Kit A is located under the seat.

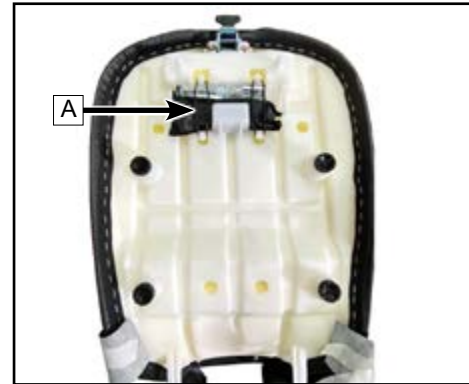

FEATURES & CONTROLS

Winch

This vehicle is equipped with a 3000-lb winch. The winch control is located on the left handle bar. To preserve battery power, only operate the winch when the engine is running. Please refer to the winch operation section of this manual or consult with your dealer on the use of the winch before using your vehicle.

GENERAL SAFETY PRECAUTIONS REGARDING WINCH USE

Moving Part Hazards

To prevent serious injury and property damage:

- Do not operate a winch without reading and understanding the instructions located in the winch operation section of this manual.
- Keep hands clear of wire rope, hook and fairlead opening during operation.
- Always use the supplied hook strap for applying tension when spooling in wire rope.
- Stand clear of wire rope and load during operation.
- Keep others away.
- Inspect winch installation and wire rope condition before operating the winch
- Do not use the winch as a hoist.
- Do not use the winch to move people.
- Do not exceed the rated capacity of the winch.
- Never touch wire rope or hook while in tension.
- Be certain the anchor point you select will withstand load.
- Never attach wire rope back onto itself. Use a chain or tree trunk protector on the anchor point.

FEATURES & CONTROLS

- Prior to initiating a winching operation, be sure any element which can interfere with safe winching is removed.
- Do not disengage the winch drum when it is under load or the wire rope is in tension.
- Take your time. Poor rigging of the wire rope and load causes accidents.
- The wire rope must always spool onto the drum in the direction indicated by the rotation indicator.

To avoid injury and property damage:

- Do not use the winch to secure the vehicle or a load for transport.
- Do not submerge the winch in water.
- Do not use the winch to tow other vehicles.
- Wear heavy leather gloves when handling the wire rope.
- Never winch with less than 5 wraps of wire rope around the drum.
- Caution should be used if the vehicle is tied down for a winching operation. This may lead to damage to the frame.

FEATURES & CONTROLS

Winch Operation

(Select Markets) Your vehicle may be equipped with a winch that can pull certain capacities and types of loads. It is useful for vehicle self-recovery when stuck, assisting another vehicle in recovery, moving fallen trees, removing brush, etc.

Consider practicing the operation and use of your winch before you actually need to use it.

The safety warnings, operating precautions and instructions in this section apply if your vehicle came equipped with a winch, or if you choose to install an accessory winch on your vehicle:

Winch Safety Warnings

These safety warnings apply if your vehicle is equipped with a winch, or if you choose to install an accessory winch on your vehicle:

- Read and understand all sections of this manual.
- Improper winch use or failure to correctly follow the winch guidelines, instructions, and warnings in this manual can result in SEVERE INJURY or DEATH.
- Improper or lack of winch maintenance and service could lead to SEVERE INJURY or DEATH.
- Always keep body, hair, clothing, and jewelry clear of the winch cable, fairlead, and hook during winch operation.
- Always keep the area around the vehicle, winch, winch cable and load clear of people, pets, and distractions during winch operation.
- Always wear eye protection and heavy gloves during winch operation.
- Never use alcohol or drugs before or while operating the winch.

FEATURES & CONTROLS

- Never allow children under 16 years of age to operate the winch.
- Never attempt to “jerk” a load attached to the winch by moving the vehicle.
- Never winch up or down, or to the sides at sharp angles. This can destabilize the winching vehicle and possibly cause it to move without warning.
- Never attempt to winch loads that weigh more than the winch capacity rating.
- Never touch, push, pull, or straddle the cable while winching a load.
- Never let the winch cable run through your hands, even if wearing heavy gloves.
- Never release the drum on the winch when the winch cable is under load.
- Never use the winch for lifting or transporting people.
- Never use the winch to hoist or suspend a vertical load.
- Never retract the hook fully into the winch. This can cause damage to system components.
- Never operate the winch or the vehicle if they are in need of repair or service.
- Always turn the ignition switch OFF and unplug the remote control (if equipped) to prevent inadvertent activation or unauthorized use when the vehicle or winch are not being used.

Winch Operating Precautions

These operating precautions should always be followed if your vehicle is equipped with a winch, or if you choose to install an accessory winch on your vehicle:

- Always inspect your winch and winch cable before each use.
- Always use the provided hook strap when pulling cable out or guiding cable in. Never grab the hook.
- Always align the load directly in front of the vehicle and winch as much as possible. Avoid winching with the cable at a sharp angle to the winching vehicle’s centerline whenever possible.

FEATURES & CONTROLS

- If winching at an angle is unavoidable, follow these precautions while operating:
- A. Look at the winch drum occasionally. Never let the winch cable “stack” or accumulate at one end of the drum. Too much cable at one end of the drum can damage the winch and cable.
- B. If cable stacking occurs, stop winching. Follow the ‘Winch Cable Spooling Guidelines’ section in this manual to redistribute the cable evenly before continuing.
- Always apply the vehicle’s park brake and/or park mechanism to hold the vehicle in place during winching. Use wheel chocks when necessary.
- Always maintain at least five full turns of cable wrapped around the winch drum at all times. The friction provided by the wrapped cable allows the drum to pull on the winch cable and move the load.
- Never grease or oil the winch cable. This will cause the winch cable to collect debris that will shorten the life of the cable.
- The winch motor and relay connector may become hot during continuous use. When winching for more than 45 seconds, or if the winch stalls during operation, stop and allow the winch components to cool for a minimum of 10 minutes before using it again.
- Never operate the winch without running the engine. The engine’s charging system helps keep the battery maintained. Battery reserve capacity can be quickly exhausted by heavy winch use, rendering the starting system inoperable.
- Always operate with concern for the environment. Do not purposely damage trees, etc.

Basic Winch Operation

Follow these operating instructions if your vehicle is equipped with a winch, or if you choose to install an accessory winch on your vehicle. Read *Winch Safety Warnings and Winch Operating Precautions* on the preceding pages before using your winch.

FEATURES & CONTROLS

BEFORE YOU BEGIN - Realize that each winching situation is unique:

- Take your time to think through the winch operation you are about to perform.
 - Proceed slowly and deliberately.
 - Never hurry or rush during winching.
 - Always pay attention to your surroundings.
 - Be prepared to change your winching strategy if it is not working.
 - Remember that although your winch is very powerful, there are simply some situations that you and the winch will not be able to deal with. Do not be afraid to ask others for help when necessary.
1. Always inspect the vehicle, winch, cable and controls for signs of damage or parts in need of repair before each use. Pay particular attention to the first 3 feet (1 meter) of winch cable if the winch is used (or has been used) for lifting a plow. Promptly replace any worn or damaged cable.
 2. Apply the vehicle's park brake and/or park mechanism to hold the vehicle in place during winching. Use wheel chocks when necessary.
 3. Release the winch drum and pull out the required length of cable. Always use the hook strap to handle the hook. Never remove the hook strap from the hook.

CAUTION: Always maintain a minimum of five (5) full turns of cable around the winch drum at all times. The friction provided by wrapping cable allows the drum to pull on the cable and move the load.

4. Attach the hook onto the load, or use a tow strap or chain to secure the load to the winch hook. Never hook the winch cable back onto itself. This can damage the winch cable and result in cable failure.

FEATURES & CONTROLS

WARNING: Never use a 'recovery strap' for winching. Recovery straps are designed to stretch and could release excessive energy that can result in SEVERE INJURY or DEATH if the strap or winch cable breaks. Use only undamaged tow straps or chains that do not stretch.

5. Re-engage the winch drum.
6. Slowly winch in slack of the winch cable until it is gone, then stop and follow the instructions for 'winch damping' to ensure safe operation:
 - A. Place a damper on the mid-point of winch cable length to absorb energy that could be released by a winch cable failure. A damper can be a heavy jacket, tarp, or other soft, dense object. A damper can absorb much of the energy released if the cable breaks during winching. Even a tree limb can help as a damper if no other items are available to you.
 - B. Lay the damper on top of the mid-point of the winch cable length.
 - C. On a long pull, it may be necessary to stop winching so the damper can be repositioned to a new mid-point. Always release the tension on the winch cable before repositioning the damper.
 - D. Avoid being directly in line with the winch cable whenever possible. Also, never permit others to stand near or in line with the winch cable during winch operation.
7. Stop winching as soon as the job is completed or the load can be moved without the help of the winch.
8. Detach the winch hook, then rewind the cable evenly back onto the drum following the instructions in this manual.

FEATURES & CONTROLS

Vehicle Recovery Methods

Vehicle Self-Recovery:

- A. Release the winch drum and pull out the required length of cable.
- B. Whenever possible, pick an anchor point that aligns the winch cable to the vehicle's centerline as close as possible. This will help the spooling of the winch cable and reduce the load on the fairlead.
- C. Attach the winch hook to an anchor point. NOTE: If freeing a stuck vehicle by attaching to a tree, use an item such as a tow strap to avoid damaging the tree during winch operation. Sharp cables and chains can damage and even kill trees. Always respect the environment.
- D. Re-engage the winch drum.
- E. Slowly winch in any slack in the winch cable, then damper it.
- F. Shift to the lowest gear available that will propel the vehicle in the direction of winching.
- G. Carefully apply winch power and throttle together to free the vehicle.

CAUTION: Using the vehicle throttle and winching at the same time has risk and is optional. Place the vehicle in neutral and use only the winch if unsure of your operating abilities.

- H. Stop winching as soon as the stuck vehicle is able to propel itself without the help of the winch.
- I. Detach the winch hook, then rewind the cable evenly back onto the drum following the instructions in this manual.

CAUTION: The ONLY time a winch-equipped vehicle should be moving and using the winch is for self-recovery. The winch-equipped vehicle should NEVER use motion to "shock-load" the winch cable in an attempt to recover a second stuck vehicle. See 'Winch Shock Loading' section in this manual for more information.

FEATURES & CONTROLS

Recovery of Another Vehicle:

- A. Release the winch drum and pull out the necessary length of cable.
- B. Attach the winch hook to the vehicle. Whenever possible, pick an anchor point on the stuck vehicle that aligns the winch cable to the winching vehicle's centerline as close as possible. This will help the spooling of the winch cable and reduce the load on the fairlead.

CAUTION: Never attach the winch hook to a suspension component, brush guard, bumper or cargo rack. Vehicle damage may result. Always attach the hook to the strongest available portion of the vehicle frame or hitch.

- C. Re-engage the winch drum.
- D. Slowly winch in any slack in the winch cable, then damper it.
- E. Shift to the lowest gear available on the stuck vehicle that will propel it in the direction of winching.
- F. Carefully apply winch power and the stuck vehicle's throttle together to free it.
- G. Stop winching as soon as the stuck vehicle is able to propel itself without the help of the winch.
- H. Detach the winch hook, then rewind the cable evenly back onto the drum following the instructions in this manual.

Winch Cable Care

Always inspect your winch cable before each use for worn or kinked winch cable. Never use a cable that is damaged. Follow these guidelines for inspection and use:

- A winch cable made of wire rope that is kinked, deformed, or bent is permanently and severely damaged. Promptly discontinue use of a winch cable in this condition.

FEATURES & CONTROLS

- A kinked winch cable made of wire rope that has been “straightened out”, even though it may look usable, has been permanently and severely damaged. It can no longer achieve its load capacity rating. Promptly discontinue use of a winch cable in this condition.
- A winch cable made of synthetic rope should be inspected for signs of fraying. Replace the cable if fraying is observed. Promptly discontinue use of a winch cable in this condition.
- Replace synthetic winch cable if fused or melted fibers are discovered. The synthetic rope will be stiff and appear smooth or glazed in the damaged section. Promptly discontinue use of a winch cable in this condition.
- Never replace a synthetic winch cable with consumer-grade polymer rope. Only use cable that is specifically designed for winch use.
- Never grease or oil a wire rope winch cable. This will cause the cable to collect debris that will shorten the life of the cable.
- Never operate the winch with a damaged hook or latch. Always replace damaged parts before using the winch.

WARNING: Replace the winch cable and components at the first sign of damage to prevent SEVERE INJURY or DEATH in the event of failure.

Winch Cable Spooling Guidelines

After winching is complete, especially if winching at an angle, it may be necessary to respool the winch cable evenly across the drum. This reduces the chances of the winch cable “wedging” itself between lower layers of cable. You will need an assistant to perform this task:

- A. Release the winch drum.

FEATURES & CONTROLS

- B. Pull out the winch cable that is wrapped unevenly onto the drum.
- C. Re-engage the winch drum.
- D. Have an assistant pull the winch cable hook strap tightly to apply about 100 lbs. (45 kg) of tension.
- E. Slowly winch the cable in while the assistant moves the end of the cable back and forth horizontally to evenly distribute it onto the drum.

Winch 'Shock Loading'

Your winch (if equipped) is designed and tested to withstand the loads produced when operated from a stationary vehicle. Always remember that the winch, cable and components are NOT designed for shock loading. Follow these guidelines:

- Never attempt to “jerk” a load with the winch. For example, never take up cable slack by moving the winching vehicle in an attempt to move an object. This is a dangerous practice that generates high loads which may exceed the strength of the components. Even a slow moving vehicle can create a large shock load which can cause damage.
- Never quickly turn the winch ON and OFF repeatedly (“jogging”). This is a form of shock loading. This puts extra load on the winch components, the cable, and generates excessive heat in the motor and relay assembly.
- Never tow a vehicle or other object with your winch. Towing with a winch produces shock loading even when towing at slow speeds. Towing from the winch also positions the towing force high on the vehicle, which can cause vehicle instability and the possibility of an accident.

FEATURES & CONTROLS

- Never use recovery straps with your winch. This is a form of shock loading. Recovery straps are designed to stretch and can store energy. Stored energy in the recovery strap is released if a failure occurs, making the event even more hazardous. Similarly, never use elastic “bungie” cords for winching.
- Never use the winch to tie down the vehicle to a trailer or other transporting unit. This is a form of shock loading that can cause damage to the winch components, the cable, or the transporting unit.

FEATURES & CONTROLS

Front panel access

Your vehicle is equipped with an access panel on the front rack.

To remove the panel:

1. Lift and pull the rubber retaining strap away from the panel until the strap releases from the front tab.
2. Lift up on the nose of the panel. Slide the panel upward toward you and away from the rack.

To reinstall the panel:

1. Align the tabs at the rear of the cover into the rack and place the cover into the rack opening.
2. Press down on the center of the cover.
3. Lift and push the rubber retaining strap onto the front panel tab to secure it.

Rear storage

Your vehicle is equipped with a storage compartment at the rear of the vehicle.

To open:

1. Lift and pull the rubber retaining strap away from the cover until the strap releases from the tab.
2. Pull the cover toward you.

To close:

1. Secure the cover onto the opening.
2. Press on the center of the cover.
3. Lift and pull the rubber retaining strap onto the cover tab to secure it.

FEATURES & CONTROLS

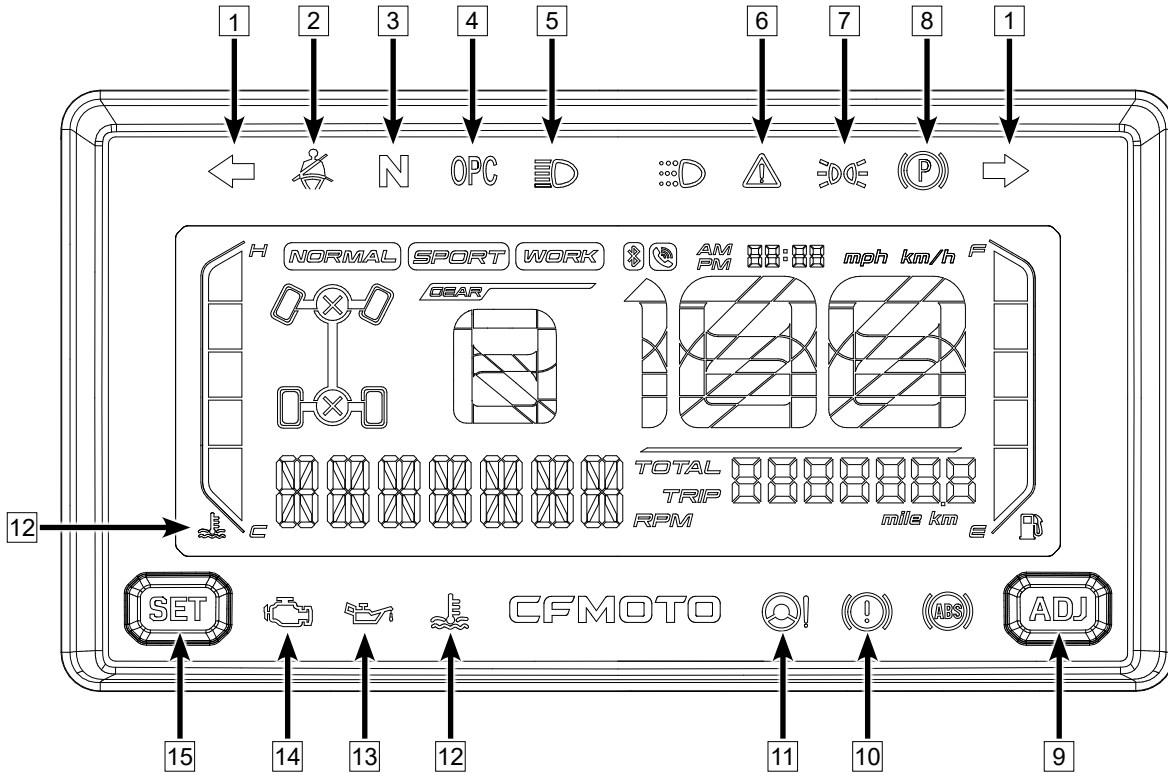

FEATURES & CONTROLS

Dashboard Indicators and Warnings

1	Turning light	6	Override indicator	11	EPS indicator
2	Seat belt warning indicator	7	Position light	12	Coolant temp. warning indicator
3	Neutral indicator	8	Parking brake indicator	13	Oil pressure signal indicator
4	OPC indicator	9	ADJ - mode adjust button	14	EFI fault indicator
5	High beam indicator	10	Brake fault warning indicator	15	SEL - mode select button

NOTE :

Turning light is available only in select countries.

FEATURES & CONTROLS

Indicators and Warnings

1. Turning Light (If equipped)

When switch turns to right turning light position, the right turning indicator will be on.

When switch turns to left turning light position, the left turning indicator will be on.

2. Seatbelt Warning Indicator

Seatbelt Reminder. This indicator displays when the seat belt is not fastened. The latch plate is not pushed securely into the buckle, the indicator on the dashboard will be on.

3. Neutral indicator

This indicator displays when the transmission is in neutral position.

4. OPC Indicator

When the driver leaves the seat without shifting to the parking position, this indicator will be on and alarm sounds.

5. High Beam Indicator

This indicator illuminates when the headlight switch turns to high beam position.

6. Override Indicator

When pressing the override button, the indicator is on and 4WD-LOCK speed limitation will be released in this state.

7. Position Light Indicator

This indicator illuminates when the light switch turns to position light.

FEATURES & CONTROLS

8. Parking Brake Indicator

This indicator displays when parking brake function is activated.

9. ADJ - Mode Adjust Button

Use this key together with “SEL” key to set the information on dashboard.

10. Brake Fault Warning Indicator

This indicator displays when brake fluid level is very low. Add DOT4 brake fluid and contact your dealer. Low brake fluid level may lead to air in the brake system, causing brake fault and lead to serious accident.

11. EPS Indicator

The indicator will be on when a fault occurs in the Electronic Power Steering system. Please stop the vehicle and contact your dealer to inspect and eliminate the fault. Continuing to operate could lead to permanent EPS damage and increase the steering force.

12. Coolant Temperature Warning Indicator

Both over-low and over-high of the coolant temperature are abnormal. Idle the vehicle to warm the engine when it's too cold, and park the vehicle when it's too hot to prevent the coolant from boiling. Keep the coolant temperature in a normal range.

13. Oil Pressure Indicator

The oil pressure indicator is on when the oil pressure is very low. Please have your vehicle stopped safely at once when the indicator is on, and contact your dealer to eliminate the fault.

FEATURES & CONTROLS

14. EFI Fault Indicator

This indicator displays when a fault occurs in the Electronic Fuel Injection system. Please stop the vehicle and contact your dealer to eliminate the fault, or it may result in serious engine damage.

15. SEL - Mode Adjust Button

Use together with “ADJ” key to adjust functions on the dashboard.

FEATURES & CONTROLS

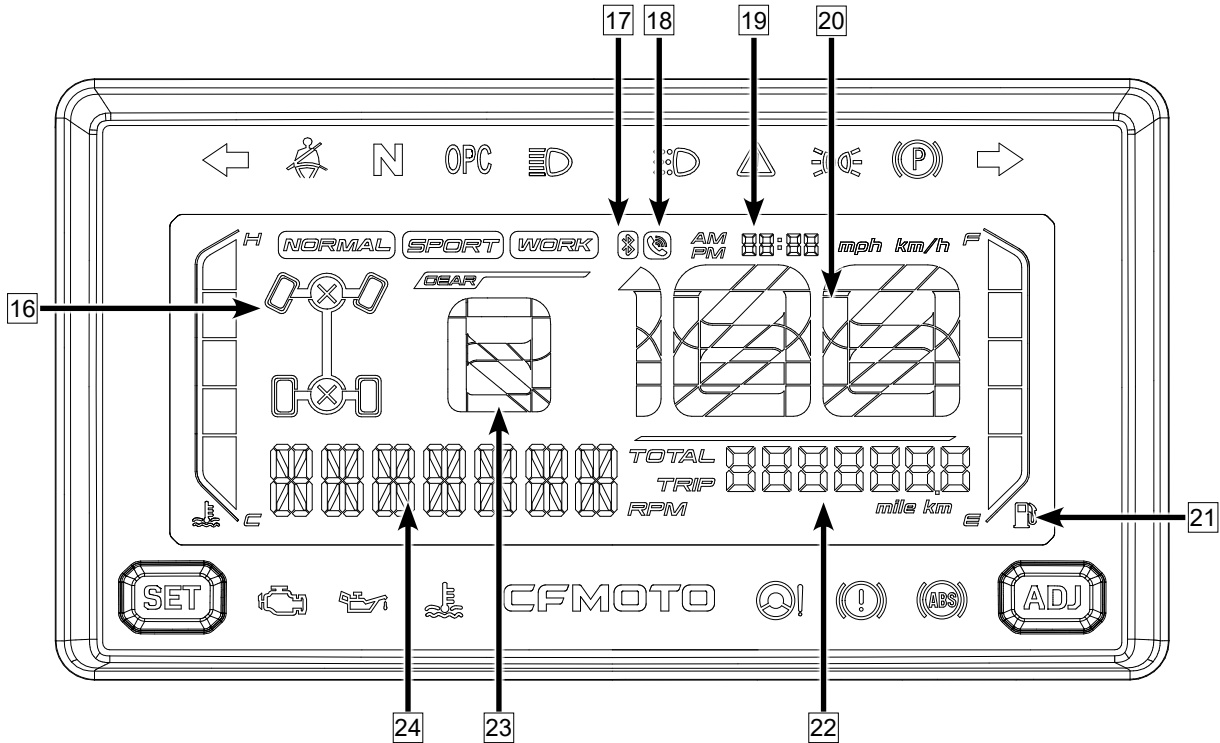

FEATURES & CONTROLS

Dashboard Indicators and Warnings

16	Drive mode	19	Clock	22	Rider Information Center
17	Bluetooth indicator	20	Speedometer	23	Gear position indicator
18	Call indicator	21	Fuel gauge indicator	24	Engine RPM

FEATURES & CONTROLS

16. Drive Mode

Display the current drive mode, there are three modes, 2WD, 4WD and 4WD-LOCK. If the mode is not engaged successfully, the indicator will flash.

17. Bluetooth Indicator (Available in Select Markets)

This vehicle is equipped with bluetooth function for connecting and disconnecting calls from a mobile phone. The bluetooth icon will not light when it is not paired and connected to a phone. It will flash during pairing and connecting, and remains on after pairing successfully and staying connected. The telephone icon will flash when there is an incoming call, it remains on while the call is connected. and it turns off when the call is disconnected.

Short-press the “SEL” button to answer the call, and short-press “ADJ” button to finish the call.

To pair, open the bluetooth function in the mobile phone, turn the vehicle main key switch to “ON”, then connect to the vehicle’s bluetooth feature using the phone.

 WARNING
--

Do not operate the vehicle while using bluetooth. Always stop the vehicle before answering a call. Distracted driving can result in an accident causing serious injury or death.

18. Call Indicator

After bluetooth pairing successfully, this indicator flashes when there is an incoming call, and it displays “CALL IN”. Short-press “SEL” to accept the call, short-press “ADJ” to finish the call.

19. Clock

Display the current time. This dashboard section can be adjusted to correct time by using the “ADJ” and “SEL” button.

FEATURES & CONTROLS

20. Speedometer

Display the current vehicle speed. Speedometer section can be toggled to display the vehicle speed in Kilometers per hour (km/h) or Miles Per Hour (MPH) by the “ADJ” and “SEL” keys.

21. Fuel Gauge / Low Fuel Indicator

Display the fuel level in the fuel tank.

22. Rider Information Center

Indicates the total mileage the vehicle has traveled. Press “SEL” button to toggle to TRIP meter, or engine hour, or EFI fault code, or battery voltage, or dashboard brightness, or EPS fault code.

23. Gear Position Indicator

Displays the current gear position.

24. Engine RPM

Indicate the engine current RPM.

FEATURES & CONTROLS

Dashboard Navigation / Settings / Adjustments					
Item	Displays	SEL	ADJ	Operation	Result
Odometer	Total Distance	Short press		Shifts to trip	Trip
Trip	Trip Distance	Short press		Shifts to engine hour	Engine hour
Trip	Trip Distance		Long press	Trip resets to zero	Trip Distance Reset
Engine hour	H	Short press		Shifts to EFI fault code	EFI fault code
EFI fault code	EFI fault code	Short press		Shifts to voltage	Voltage
Voltage	U	Short press		Shifts to dashboard brightness	Dashboard brightness
Dashboard brightness	Brightness level	Short press		Shifts to odometer	Odometer
			Short press	Adjust brightness+1	L-l-g-H-5
Home interface	Home interface	Long press		Shifts to time setting	Hour setting
			Short press	Shifts to dashboard brightness	Home interface
Shifting for time setting, time format and speed unit	Hour setting	Short press		Shifts to time setting	Minute setting
			Short press	Increase 1 / press	Hour setting
			Long press	Incremental 1-24	Hour setting
	Minute setting	Short press		Shifts to time unit	12/24 time format setting
			Short press	Increase 1 / press	Minute setting
		Long press		Incremental 00-59	Minute setting
	12/24 time format setting	Short press		Shifts to unit setting	Speed unit setting
			Short press	Shifts to time format	12/24 time format setting
	Unit setting	Short press		Back to home interface	Home interface
			Short press	Shifts to speed unit	Speed unit setting

OPERATION OF YOUR ATV

Operation of your ATV

Break-In Period

The break-in period for your new ATV is very important. Careful treatment of a new engine at the beginning of ownership will result in more efficient performance and longer life. Perform the following procedures carefully:

1. Select an open area that allows room to familiarize yourself with vehicle operation and handling.
2. Place the ATV on a level surface.
3. Fill the fuel tank with gasoline.
4. Check the engine oil level. Add the recommended oil if necessary to maintain the oil level between the minimum and maximum indicators on the dipstick.
5. Position yourself in the operating position on the vehicle and start the engine. Allow the engine to idle for a short period before operating.
6. Press the foot brake, select the desired gear, and then release the foot brake.
7. Apply throttle. Drive slowly at first, varying throttle positions not more than $\frac{1}{2}$ throttle for 10 hours or 100 miles, then another 10 hours or 100 miles of not more than $\frac{3}{4}$ throttle (whichever interval arrives first). Do not operate at sustained idle or sustained wide open throttle.
8. Do not pull or carry any loads during the break-in period.
9. At the end of the break-in period, change the oil and filter (20hrs or 200 miles/320km).

OPERATION OF YOUR ATV

CAUTION

During the break-in period:

- Do not load or tow cargo.
- Do not operate at sustained full throttle. Damage to engine parts or decrease engine life may result if excessive wide open throttle is used during the first 20 hours of use.
- Do not run engine with throttle over 1/2 open during the first 10 hours (or 100 miles/160km) of use.
- Do not run engine with throttle over 3/4 open during the first 10 to 20 hours (or the second 100 miles/160km) of use.
- Use of any oil other than those recommended may cause serious engine damage. CFMOTO recommends the use of 10W-40 for 2-cylinder 4-stroke engines. Changing engine oil viscosity to 5W-40 or 15W-40 due to cold or hot environments is acceptable. Reference the chart below for ambient temperature and viscosity choice.

Recommended Engine Oil Viscosity

Oil Viscosity				15W-40				
				10W-40				
					5W-40			
F°	-22	-4	14	32	50	68	86	104
C°	-30	-20	-10	0	10	20	30	40

OPERATION OF YOUR ATV

Pre-Ride Inspection

Before each use of the vehicle, a best practice is to check the vehicle according to the “Perform daily before operating the vehicle” checklist in maintenance sheet.

 WARNING
--

If a proper inspection is not done before each use, severe damage to the vehicle, severe injury, or death could result. Always inspect the vehicle before each use to ensure it is in proper operating condition.

OPERATION OF YOUR ATV

Starting the Engine

Starting a Cold Engine

WARNING

Engine exhaust contains poisonous carbon monoxide and can cause loss of consciousness resulting in severe injury or death. Never run an engine in an enclosed area.

CAUTION

Operating the vehicle immediately after starting could cause engine damage. Allow the engine to warm up for several minutes before operating the vehicle.

When the vehicle can not be started immediately, do not activate the starting system continuously. Failure to start the ignition system multiple times may cause the starting motor to burn out.

Starting a Cold Engine

1. Verify the gear selector is shifted to the Parking or Neutral position.
2. Apply the foot brake.
3. Turn the engine stop switch and main key switch to “” (ON)
4. Verify the throttle is completely closed, then push the start switch on the left-hand control.
5. Once the engine starts, continue to warm the engine for a short period before operating the vehicle.

OPERATION OF YOUR ATV

NOTE

Do not activate the starting system more than 10 seconds on each attempt. If the engine fails to start, release the start switch, pause a few seconds before the next attempt, then push the start switch again. Each attempt should be as short as possible to preserve battery energy.

CAUTION

Operating the vehicle immediately after starting could cause engine damage. Allow the engine to warm up for a short period before operating the vehicle.
--

NOTE

The engine can be started in any gear if the brake is applied. However, a best practice is to shift into Neutral or Park before starting the engine. If the neutral indicator light on the dashboard does not come on when the gear selector is in neutral position, ask your dealer to inspect the vehicle electrical circuit or adjust the gear shifting system.

 WARNING
--

Excessive throttle operation while in speed limit mode may cause fuel to build in the exhaust, resulting in engine popping and/or engine damage.
--

OPERATION OF YOUR ATV

Gear Selector Operation

Shifting

CAUTION

To avoid transmission damage, return the throttle to the closed position, stop the vehicle, and apply the foot brake before shifting.

NOTE

Low gear is the preferred transmission gear selection for all forward motion other than prolonged high speed travel.

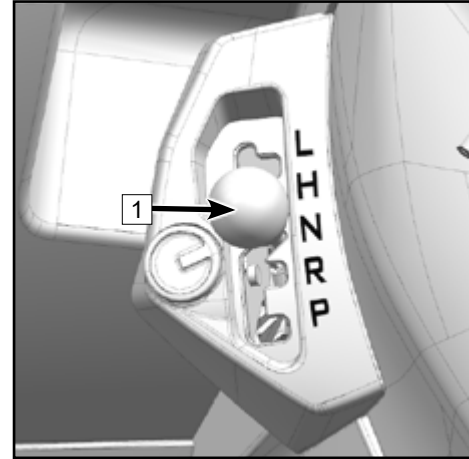

1 Gear selector

OPERATION OF YOUR ATV

Shifting out of Park

1. Verify the throttle is closed.
2. Apply the foot brake.
3. Shift to the desired gear by moving the gear selector along the shift guide.

Shifting: Neutral to High Gear

1. Verify the throttle is closed and the vehicle is stopped completely.
2. Apply the foot brake.
3. Shift to 'H' by moving the gear selector along the shift guide.

Shifting: High Gear to Low Gear

1. Verify the throttle is closed and the vehicle is stopped completely.
2. Apply the foot brake.
3. Shift to 'L' by moving the gear selector along the shift guide.

Shifting: Low Gear to High Gear

1. Verify the throttle is closed and the vehicle is stopped completely.
2. Apply the foot brake.
3. Shift to 'H' by moving the gear selector along the shift guide.

Shifting: to Reverse Gear

1. Verify the throttle is closed and the vehicle is stopped completely.
2. Apply the foot brake.
3. Shift to 'R' by moving the gear selector along the shift guide.

OPERATION OF YOUR ATV

4. Check behind you for people or obstacles, then release the foot brake pedal.
5. Apply the throttle lever gradually and continue to watch behind you while moving backward.

 WARNING
--

When you shift into reverse, make sure there are no obstacles or people, and the area is safe behind you. When it is safe to proceed, go slowly.
--

Shifting: Reverse to Park

1. Verify the throttle is closed and the vehicle is stopped completely.
2. Apply the foot brake.
3. Shift to 'P' by moving the gear selector along the shift guide.

NOTE

The gear selector must not be shifted into reverse gear without applying the foot brake.

The gear shift indicators should display corresponding to the actual gear position, if the indicator does not display, ask your dealer to inspect the vehicle electrical circuit or adjust the gear shifting system.

Due to the synchronizing mechanism in the engine, an indicator may not display until ATV starts moving.

Do not use high gear for continuous slow speed travel or towing, as this can lead to excessive heating of the clutch system, which may damage components.

OPERATION OF YOUR ATV

Hauling Cargo

Your vehicle is equipped with front and rear cargo racks, and a hitch receptacle for towing. Follow these guidelines for hauling and towing of cargo:

WARNING

Overloading the vehicle, carrying or towing cargo improperly, can alter vehicle handling and may cause loss of control or brake instability. Always follow these precautions when hauling cargo:

- Always use low gear while towing to avoid clutch wear and belt issues.
- Reduce speed when hauling or towing loads.
- Never exceed the stated load capacity for this vehicle.
- All loads must be secured before operation. Unsecured loads may shift and create unstable operating conditions, which could result in loss of control of the vehicle.
- When operating over rough or hilly terrain, reduce speed and cargo to maintain stable driving conditions.
- Use extreme caution when applying brakes with a loaded vehicle. Avoid terrain or situations that may require backing downhill.
- Weight distribution on the front and rear racks should be as far forward and as low as possible. Carrying a high load raises the center of gravity and creates an unstable operating condition. Reduce load weight when the cargo center of gravity is high. When handling off-centered loads that cannot be centered, secure the load and operate with extra caution.
- When operating with loads extending beyond the rack. Stability and maneuverability may be adversely affected, causing the machine to overturn.

OPERATION OF YOUR ATV

- Carrying a load on only the front rack or the rear rack may cause an imbalanced condition and increases the possibility of vehicle overturn. Balance loads proportionally between the front rack and the rear rack, but do not exceed the stated load capacity.
- Do not obstruct the headlights when loading the front rack.
- Always attach to the towable using the hitch point. Never exceed the recommended tongue weight.
- Using chains, straps, rope or other materials to tow objects is not recommended, as these items could get caught in the rear wheels, resulting in vehicle damage or personal injury.
- While towing, the vehicle should never exceed 10 mph (16 km/h) towing a load on a level surface. Vehicle speed should never exceed 5 mph (8 km/h) when towing loads in rough terrain, while cornering, or while ascending or descending a hill.

OPERATION OF YOUR ATV

Load Distribution

Your ATV has been designed to carry or tow a certain amount of load. Always:

- Read and understand the load distribution warnings listed on the warning labels.
- Never exceed the specified weights.
- Cargo weight should be mounted as low as possible.
- Cargo should be loaded on the racks as far forward as possible.
- When operating over rough or hilly terrain, reduce speed and cargo to maintain stable driving conditions.

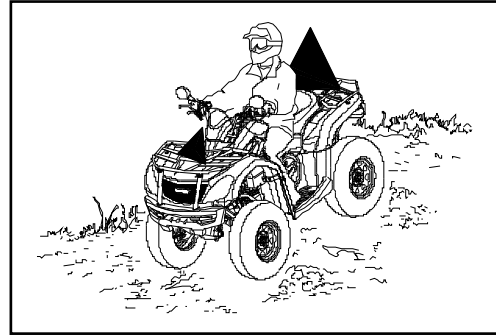

OPERATION OF YOUR ATV

Driving Safely

Responsibilities of the operator

As the operator of this ATV, your common sense, judgment, and abilities are the only factors that will prevent injury to yourself, to others around you, and/or damage to the vehicle or environment.

Recreational, group, and distance riding

One of the benefits of this vehicle is that it can take you off-road away from most communities. Stay away from areas designated for other types of off-road use unless it is specifically allowed. This includes snowmobile trails, equestrian trails, cross country ski trails, mountain bike trails, etc. Join a local ATV club. A club can provide you with a map and advice, or inform you about areas where you can ride.

Always keep a safe distance from other riders ahead of you and behind you when riding in a group. Never operate carelessly or make unexpected maneuvers with other ATVs close by. Stay on designated trails and riding areas, and discourage others from operating in unauthorized locations.

Environment

Off-road ATV recreation is a privilege. Maintain your privilege by respecting the environment and the rights of others to enjoy it. Chasing wildlife is illegal. Wildlife can die of exhaustion if chased by a motorized vehicle. Never purposely damage the terrain unless the operating area is designated for that type of activity. Observe the rule... "what you take in, carry out". Do not litter.

OPERATION OF YOUR ATV

Practice

The driving procedures described in this manual should be practiced at slow speed many times in a large area with no obstacles. If an incorrect technique is used, your ATV may continue to go straight. If the ATV does not turn, come to a stop and then practice the procedure again. If the riding surface is slippery or loose, it may help to transfer more of your weight to the front wheels by moving forward on the seat. Once you have learned the proper techniques, you should be able to perform maneuvers at higher speeds or in tighter curves.

Improper driving procedures such as abrupt throttle changes, excessive braking, incorrect body movements, or too much speed for the sharpness of the turn may cause the ATV to tip. If the ATV begins to tip over to the outside while negotiating a turn, lean more to the inside. It may also be necessary to gradually let off on the throttle and steer to the outside of the turn to avoid tipping over.

Remember: Avoid higher speeds until you are thoroughly familiar with the operation of your ATV.

NOTE

Low gear is the preferred transmission gear selection for all forward motion other than prolonged high speed travel. Do not use high gear for continuous slow speed travel or towing, as this can lead to excessive heating of the clutch system, which may damage components.

OPERATION OF YOUR ATV

Driving procedure

1. Sit upright with both feet on the footrests and both hands on the handlebars.
2. Start the engine and allow it to warm up. Apply the foot brake, then shift the transmission into low gear.
3. Check your surroundings and determine your path of travel.
4. Release the brakes.
5. Slowly press the throttle with your right thumb and begin driving. Vehicle speed is controlled by the amount of throttle opening.
6. Drive slowly. Practice maneuvering while using the throttle and brakes on a level surface.



OPERATION OF YOUR ATV

Making Turns

To make a turn, steer in the direction of the turn, leaning your upper body to the inside of the turn while supporting your weight on the outer footrest. This technique alters the balance of traction between the wheels, allowing turn to be made smoothly. The same leaning technique should be used for turning in reverse.

NOTE

Practice making turns at slow speeds before attempting to turn at faster speeds.

WARNING

Turning at sharp angles or at excessive speeds can result in vehicle overturn and lead to serious injury.

Avoid turning at sharp angles.

Never make turns at high speeds.

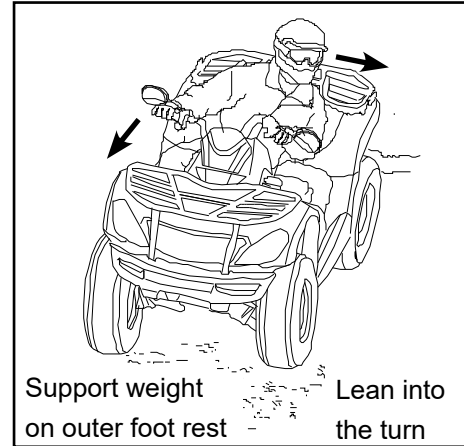

OPERATION OF YOUR ATV

ATV turning dynamics

To achieve maximum traction while operating in 2WD or 4WD, the two rear wheels perform as one axle and turn together at the same speed. Furthermore, when operating in 4WD-LOCK mode, the front wheels will also turn together at the same speed. Therefore, unless the wheel on the inside of the turn is allowed to slip or lose some traction, the ATV will resist turning. The special turning technique described in this manual must be used to allow the ATV to make turns quickly and easily. It is essential that this skill be learned first at low speed.

Turning on curves

As you approach a curve, slow down and begin to turn the handlebars in the desired direction. As you do so, put your weight on the footboard to the outside of the turn (opposite the desired direction) and lean your upper body into the turn. Use the throttle to maintain an even speed through the turn. This maneuver will let the wheel on the inside of the turn slip slightly, allowing the ATV to maneuver the turn properly.

OPERATION OF YOUR ATV

Driving in reverse

To operate in reverse:

1. Ensure the throttle is closed and the vehicle is stopped completely.
2. Apply the foot brake, then shift the transmission into reverse gear.
3. Check for obstacles or people behind the vehicle.
4. When it's safe to proceed, release the brakes, slowly press the throttle with your right thumb, and back slowly. Vehicle speed is controlled by the amount of throttle opening.

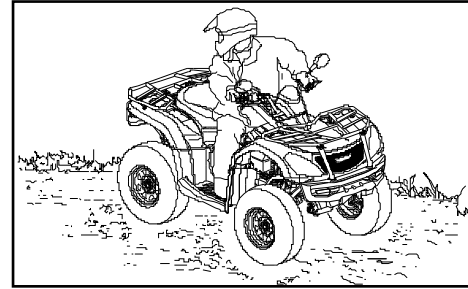

NOTE

Your ATV is equipped with a reverse speed limiter. The override button cannot be used. Do not operate at wide open throttle. Open the throttle just enough to maintain a desired speed.

Follow these precautions when operating in reverse:

- Always avoid backing downhill.
- Back slowly.
- When in reverse, apply the brakes lightly for stopping.
- Avoid turning at sharp angles in reverse.
- Never open the throttle suddenly while backing.

WARNING

Failure to use caution when operating in reverse can result in serious injury or death.

OPERATION OF YOUR ATV

Driving on Slippery Surfaces

Whenever riding on slippery surfaces such as wet trails, loose gravel, sand, or during freezing weather, follow these precautions:

- Slow down when entering slippery areas.
- Maintain a high level of alertness, reading the trail and avoiding quick, sharp turns which can cause skids.
- Correct a skid by turning the handlebars in the direction of the skid and shifting your body weight forward.
- Driving with 4WD engaged can assist in controlling the vehicle in slippery areas.



CAUTION

Severe damage to drive train may occur if the 4WD is engaged while the wheels are spinning.

Always engage 4WD when the wheels have traction or are at rest.

WARNING

Failure to exercise care when operating on slippery surfaces can result in loss of tire traction and cause loss of control, an accident, and serious injury or death. Never apply the brakes during a skid. Do not operate on excessively slippery surfaces. Always reduce speed and use additional caution.

OPERATION OF YOUR ATV

Driving on rough terrain

Whenever driving on rough surfaces such as trails with large rocks or other obstacles, follow these precautions:

- Slow down when encountering rough terrain.
- Maintain a high level of alertness, reading the trail in front of you as you drive. Avoid quick, sharp turns which can cause a loss of control.
- Shift your body weight to counteract the weight of the vehicle if it tips to one side.
- Driving with 4WD or 4WD-LOCK engaged can assist in controlling the vehicle.



OPERATION OF YOUR ATV

Driving over obstacles

Be alert! Learn to look ahead and to read the terrain as you drive. Be constantly alert for hazards such as logs, rocks, and low hanging branches.

Never attempt to cross over an obstacle higher than the ground clearance of the vehicle.

⚠ WARNING

Severe injury or death can result if your vehicle comes in contact with obstacles. Travel with caution on unfamiliar terrain.



OPERATION OF YOUR ATV

Driving through water

Your ATV can operate through water with a maximum recommended depth equal to the bottom of the footrests. Follow these procedures when operating through water:

- Determine water depths and current before crossing.
- Choose a crossing where both banks have gradual inclines.
- Proceed slowly, avoiding rocks and obstacles if possible.
- After crossing, dry the brakes by applying light pressure to the lever until braking action is normal.



WARNING

Avoid operating the vehicle through deep or fast-flowing water. If you cannot avoid water that exceeds the recommended maximum depth, go slowly, balance your weight carefully, avoid sudden movements, and maintain a slow and steady forward motion. Do not make sudden turns or stops, and do not make sudden throttle changes.

OPERATION OF YOUR ATV

Drying the CVT system after submersion

If water has been ingested into the CVT housing, the drive belt will likely slip and poor performance will result. To expel water and dry the CVT housing:

- Drain the CVT housing.
- Place the vehicle in neutral, and raise the engine rpm for several minutes to dry the CVT components.
- Release the throttle and shift into low gear, then test the performance of the vehicle.
- Repeat as necessary until you are satisfied all the water has been expelled. Contact your dealer if vehicle performance issues continue.

NOTE

After running the vehicle in water, it is critical to have the vehicle serviced as outlined in the maintenance schedule. The following areas need special attention: engine oil, front and rear gear cases and all grease locations. If your vehicle becomes immersed, and it's impossible to take it to your dealer before starting it, follow the steps described in this manual to remove water from the air box and engine.

⚠ CAUTION

Major engine damage can result if the vehicle is not thoroughly inspected after operation in water. If water has been ingested into the CVT housing, follow the procedure in this manual for drying out the CVT clutch system. Have the vehicle serviced by your dealer promptly if your vehicle becomes immersed or stalls in water that exceeds the footrest level. It is important to contact your dealer for service before starting the engine, as water may have been ingested in the air box and engine.

OPERATION OF YOUR ATV

Driving Uphill

Whenever traveling uphill, follow these precautions:

- Always travel straight uphill.
- Avoid steep hills (22° maximum).
- Keep both feet on the footrests.
- Shift your weight forward.
- Proceed at a steady rate of speed and throttle opening.
- Remain alert and be prepared to take emergency action. This may include quick dismounting of the vehicle.

If all forward speed is lost:

Keep your weight uphill.

Apply the front brake. When fully stopped, apply the foot brake as well, then shift gear selector into park position.

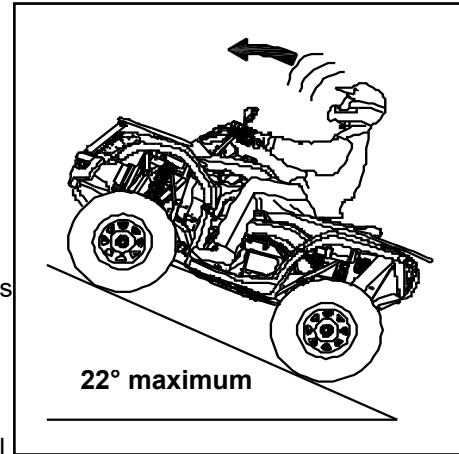

OPERATION OF YOUR ATV

If the ATV begins rolling backwards:

Keep your weight uphill. Never apply engine power. Never apply the foot brake while rolling backwards.

Apply the front brake. When fully stopped, apply the foot brake, and then shift gear selector into the parking position.

Dismount on uphill side, or to either side if ATV is pointed straight uphill. Turn the ATV around and remount following the procedure described in this manual.

WARNING

Braking and handling are greatly affected when operating in hilly terrain. Improper procedure could cause loss of control or overturn and result in serious injury or death.

Avoid climbing steep hills (22° maximum).

Use extreme caution when operating on hills, and follow proper operating procedures outlined in the owner's manual.

OPERATION OF YOUR ATV

Sidehilling

⚠️ WARNING

Improperly crossing hills or turning on hills can result in loss of control or vehicle overturn, resulting in severe injury or death. Avoid crossing the side of a hill when possible. Follow proper procedures as outlined in the owner's manual.

Sidehilling can be a dangerous type of driving and should be avoided if at all possible. If you do enter into a situation where sidehilling is necessary, follow these precautions:

- Slow down.
- Lean into the hill, transferring your upper body weight toward the hill while keeping your feet on the footrests.
- Steer slightly into the hill to maintain vehicle directions.

NOTE

If the vehicle begins to tip, quickly turn the front wheel downhill, if possible, or dismount on the uphill side immediately!

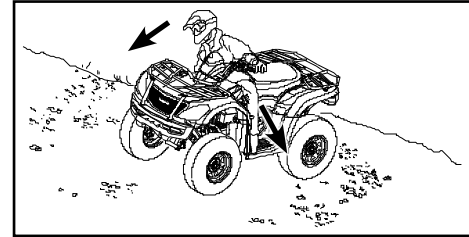

OPERATION OF YOUR ATV

Driving downhill

When traveling down a hill, follow these precautions:

- Never operate on hills over 22 degrees incline or hills too steep for your abilities.
- Slow down.
- Shift your weight to the rear of the vehicle.
- Always travel directly downhill.
- Apply the foot brake lightly to aid in slowing. Familiarize yourself with operation of the braking functions during downhill descents.
- Driving with 4WD or 4WD-LOCK engaged can assist in controlling the vehicle.

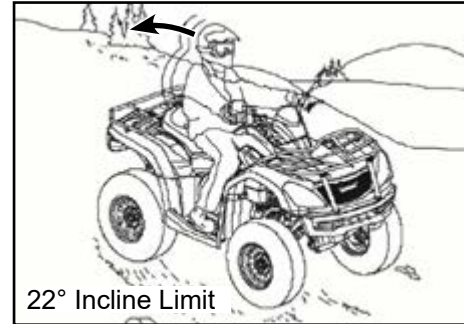

⚠️ WARNING

Excessive downhill speed can cause loss of control and lead to serious injury or death. Always reduce speed when traveling downhill.

OPERATION OF YOUR ATV

Turning Around on a Hill

One maneuver that can be used when it's necessary to turn around if stranded while climbing a hill is the K-turn:

1. Release the throttle, then apply the hand and foot brake while keeping your body weight uphill.
2. Shift the gear selector lever to the low gear position. Shut off the engine.
3. Keeping the hand brake applied, dismount on the right side of the vehicle if the vehicle is pointed straight uphill.

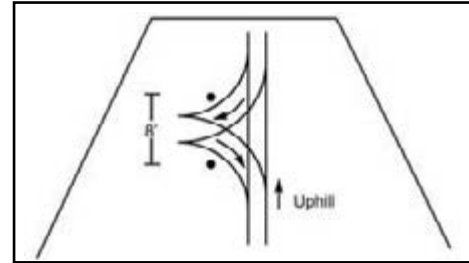

NOTE: Always dismount on the uphill side when the vehicle is pointed in a direction other than uphill.

4. Keeping the hand brake applied, move uphill (in front) of the vehicle, and pull on the right handle bar to turn the steering full left (front brake will now be closest to you).
5. Slowly release the hand brake lever, and use it to control the descent of the vehicle, which will roll downhill and to your right (as viewed from the vehicle front) until it's pointing across the hill or slightly downward. The vehicle's rolling weight is neutralized, and vehicle remount is now possible.
6. Remount the vehicle from the uphill side and shift the gear selector lever to the parking position, keeping your body weight uphill. Keep the hand brake or foot brake applied at all times if possible.
7. Restart the engine. Press the foot brake, and shift the gear selector lever to low gear position.
8. Release the brakes and proceed slowly downhill, controlling speed with the brakes, until the vehicle is on more level ground.

OPERATION OF YOUR ATV

Parking on an Incline

Avoid parking on an incline if possible. If it's unavoidable, follow these precautions:

- Turn the engine off.
- Place the gear selector to parking position.
- Always block the rear wheels on the downhill side as shown.

 CAUTION
--

The rear output shaft is locked when the transmission is in the parking position.

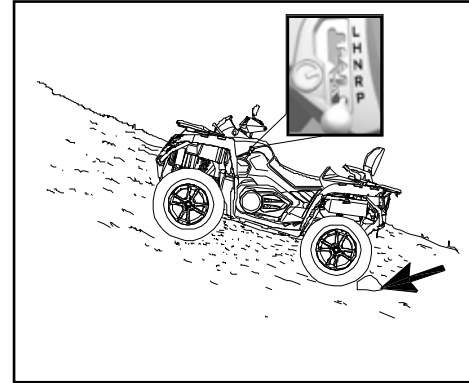

Crossing paved surfaces

Your ATV is not designed for paved surfaces and is more likely to tip over. Do not travel on sidewalks or bicycle lanes, as they are not designated for ATV use. If you must drive on a paved surface, reduce speed and avoid sudden turns, acceleration, or braking. If you have to cross a paved road, ensure you have complete visibility in both directions for oncoming traffic, and determine your exit point on the other side. Drive in a straight line toward that point. Do not make sharp direction changes or abrupt accelerations, as it may result in a tip over situation.

MAINTENANCE

Maintenance Schedule

Periodic maintenance schedule

Careful periodic maintenance will help keep your vehicle in the safest, most reliable condition.

Inspection, adjustment and lubrication of important components are explained in the periodic maintenance chart.

Inspect, clean, lubricate, adjust, and replace parts as necessary. When inspection reveals the need for replacement parts, please use genuine parts available from your dealer.

NOTE

Service and adjustments are critical. If you are not familiar with safe service and adjustment procedures, have a qualified dealer perform these operations.

Severe use definition

CFMOTO defines severe vehicle use as:

- Frequent immersion in mud, water or sand
- Extended idle
- Racing or race-style high RPM use
- Short trip cold weather operation
- Prolonged low speed, heavy load operation

For a vehicle that is subjected to severe use, decrease all maintenance and service intervals by 50%.

MAINTENANCE

NOTE

Pay special attention to the oil level. A rise in oil level during cold weather can indicate contaminants collecting in the oil sump or crankcase. Change oil immediately if the oil level begins to rise. Monitor the oil level, and if it continues to rise, discontinue to use and determine the cause or see your dealer.

Periodic Maintenance Schedule Icon Key

Maintenance intervals in the following chart are based upon average riding conditions and an average vehicle speed of approximately 12.4 mph (20 km/h). Vehicles subjected to severe use must be inspected and serviced more frequently.

- ▶ = Severe Use Item. Reduce interval by 50% on vehicles subjected to severe use.
- = Have an authorized dealer perform repairs that involve this component or system.
- = Emissions related components. Have an authorized dealer perform repairs that involve this component or system.

MAINTENANCE

KEY POINTS OF LUBRICATION SCHEDULE:

Check all components at the intervals outlined in the Periodic Maintenance Schedule. Items not listed in the schedule should be lubricated at the general lubrication interval.

- Change lubricants more often under severe use, such as wet or dusty conditions.
- Use All Season Grease on pivot points.
- Lubricate every 500 miles (800 km), before long periods of storage, after pressure washing, or after submerging drive system.

Item	Lubricant	Method
Engine oil	SAE 10W-40 SAE 5W-40 / SAE 15W-40	Screw off, clean, insert and pull out dipstick to check oil level
Brake fluid	DOT4	Keep level between upper and lower lines
Front gear case oil	SAE80W-90 GL-5	Oil capacity: 6.8 oz. (200 mL)
Rear gear case oil	SAE80W-90 GL-5	Oil capacity: 7.8 oz. (230 mL)
Suspension pivots and drive train	All Season Grease	Grease gun - Pump grease until it begins to flow from the pivot point

MAINTENANCE

Pre-Ride Maintenance Checklist

Perform these inspections before operating the vehicle:

Item		Maintenance before operation			
		Hour	Calendar	Miles (km)	Remarks
■	Steering system	-	Pre-Ride	-	Visually inspect, test, or check components. Make adjustments and/or schedule repairs when required.
■	Throttle return	-	Pre-Ride	-	
	Front suspension and axles	-	Pre-Ride	-	
	Rear suspension and axles	-	Pre-Ride	-	
	Tires	-	Pre-Ride	-	
	Brake fluid level	-	Pre-Ride	-	
	Brake lever / foot brake function	-	Pre-Ride	-	
	Brake system function	-	Pre-Ride	-	
	Wheels / fasteners	-	Pre-Ride	-	
	Engine oil level	-	Pre-Ride	-	
▶	Air filter / Air box and connections	-	Pre-Ride	-	Visually inspect. Replace filter when dirty.

▶ = Severe Use Item. Inspect frequently on vehicles subjected to severe use.

■ = Have an authorized dealer perform repairs that involve this component or system.

● = Emissions related components. Have an authorized dealer perform repairs that involve this component or system.

MAINTENANCE

Item		Maintenance before operation			
		Hour	Calendar	Miles (km)	Remarks
▶	Air box sediment tube	-	Pre-Ride	-	Inspect. If deposits are visible, clean intake tubes, air box, and replace air filter.
▶	CVT sediment tube	-	Pre-Ride	-	Inspect. If deposits are visible, drain / clean the CVT or have it serviced by a dealer.
■	Headlight aim / General lighting and turn indicators (if equipped)	-	Pre-Ride	-	Inspect. Adjust or replace lights when necessary.
▶	Radiator	-	Pre-Ride	-	Inspect for mud or debris blocking airflow. Clean surfaces when necessary.

▶ = Severe Use Item. Inspect frequently on vehicles subjected to severe use

■ = Have an authorized dealer perform repairs that involve this component or system.

● = Emissions related components. Have an authorized dealer perform repairs that involve this component or system.

MAINTENANCE

Break-In Maintenance Checklist

Perform these maintenance items when the vehicle break-in is completed:

Item		Break-in Maintenance (Perform at the interval that arrives first)			
		Hour	Calendar	Miles (km)	Remarks
	General lubrication	20	-	200 (320)	Lubricate all grease points, pivots, cables, etc.
	Engine oil / oil filter / oil strainer	20	-	200 (320)	Change oil and filter. Clean oil strainer.
▶	Engine air filter	20	-	200 (320)	Inspect. replace if dirty. do not clean
■	Engine valve clearance	20	-	200 (320)	Check and adjust as necessary.
	Front / Rear gear case oil	20	-	200 (320)	Check level. Inspect for leaks.
	Coolant	20	-	200 (320)	Check level. Inspect for leaks.
▶	Brake pads	20	-	200 (320)	Inspect pad thickness.

▶ = Severe Use Item. Reduce interval by 50% on vehicles subjected to severe use.

■ = Have an authorized dealer perform repairs that involve this component or system.

● = Emissions related components. Have an authorized dealer perform repairs that involve this component or system.

MAINTENANCE

Item		Break-in Maintenance (Perform at the interval that arrives first)			
		Hour	Calendar	Miles (km)	Remarks
	Battery	20	-	200 (320)	Check terminals, clean, test battery condition if required.
■	Idle condition	20	-	200 (320)	Inspect for proper rpm. See dealer for service if out of spec or erratic.
■	Steering / Wheel Alignment	20	-	200 (320)	Inspect steering system. See dealer for service if wheel alignment is required.
▶	Foot brake / Hand brake	20	-	200 (320)	Inspect function. Adjust as necessary.
	Gear cases, CV shafts, Propshafts	20	-	200 (320)	Inspect for leaks.
	Engine hoses, gaskets and seals	20	-	200 (320)	Inspect for leaks.

▶ = Severe Use Item. Reduce interval by 50% on vehicles subjected to severe use.

■ = Have an authorized dealer perform repairs that involve this component or system.

● = Emissions related components. Have an authorized dealer perform repairs that involve this component or system.

MAINTENANCE

Periodic Maintenance Schedule

Perform these maintenance items when the vehicle break-in is completed:

Item		Periodic Maintenance Intervals (Perform at the interval that arrives first)			
		Hour	Calendar	Miles (km)	Remarks
▶	Brake pads	10	Monthly	100 (160)	Inspect pad thickness.
	Battery	20	--	200 (320)	Check terminals. Clean and test battery condition as necessary.
	Engine hoses, gaskets and seals	20	-	200 (320)	Inspect for leaks.
▶	Air filter	50h	--	500 (800)	Always inspect pre-ride. Inspect frequently if subjected to severe use. Replace if dirty. Do not clean.
▶	CVT air intake filter screen / filter	50h	-	500 (800)	Clean filter screen or filter, replace with new one if necessary.
▶	General lubrication	50h	3M	500 (800)	Lubricate all fittings, pivots, cables, etc.

▶ = Severe Use Item. Reduce interval by 50% on vehicles subjected to severe use.

■ = Have an authorized dealer perform repairs that involve this component or system.

● = Emissions related components. Have an authorized dealer perform repairs that involve this component or system.

MAINTENANCE

Item		Periodic Maintenance Intervals (Perform at the interval that arrives first)			
		Hour	Calendar	Miles (km)	Remarks
▶	Front gear case oil	100h	12M	1000 (1600)	Inspect level. Change yearly if hours or distance interval is not met.
▶	Rear gear case oil	100h	12M	1000 (1600)	Inspect level. Change yearly if hours or distance interval is not met..
▶	Engine oil / oil filter / oil strainer	100h	12M	1000 (1600)	Inspect for color change. Change if dirty and clean strainer. Change yearly if hours or distance interval is not met.
	Cooling system	50h	6M	500 (800)	Test coolant strength. Pressure test system yearly.

▶ = Severe Use Item. Reduce interval by 50% on vehicles subjected to severe use.

■ = Have an authorized dealer perform repairs that involve this component or system.

● = Emissions related components. Have an authorized dealer perform repairs that involve this component or system.

MAINTENANCE

Item		Periodic Maintenance Intervals (Perform at the interval that arrives first)			
		Hour	Calendar	Miles (km)	Remarks
▶	Radiator	50h	6M	500 (800)	Inspect. clean external surfaces. Clean more frequently if subjected to severe use.
■	Steering system	50h	6M	500 (800)	Inspect. Lubricate.
▶	Front suspension	50h	6M	500 (800)	Lubricate. Check fasteners.
▶	Rear suspension	50h	6M	500 (800)	Lubricate. Check fasteners.
▶	Gear shift	50h	1M	500 (800)	Inspect, lubricate, adjust as necessary.
▶ ■	Throttle body / throttle cable	50h	6M	500 (800)	Inspect. Clean carbon deposits. Inspect cable and lubricate frequently if subjected to severe use.

▶ = Severe Use Item. Reduce interval by 50% on vehicles subjected to severe use.

■ = Have an authorized dealer perform repairs that involve this component or system.

● = Emissions related components. Have an authorized dealer perform repairs that involve this component or system.

MAINTENANCE

Item		Periodic Maintenance Intervals (Perform at the interval that arrives first)			
		Hour	Calendar	Miles (km)	Remarks
▶ ■	CVT drive belt	100h	12M	1000 (1600)	Inspect. Replace as necessary. See dealer for service.
■	CVT drive and driven pulleys	100h	12M	1000 (1600)	Clean and Inspect pulleys. Replace worn parts. See dealer for service.
	Fuel filter and hoses	100h	24M	2000 (3200)	Inspect routing and condition. Replace filter and high-pressure hoses every 4 years.
	Cooling hoses	100h	--	1000 (1600)	Inspect routing and condition.
▶	Valve clearance	100h	--	2000 (3200)	Inspect and adjust as necessary. See dealer for service.

▶ = Severe Use Item. Reduce interval by 50% on vehicles subjected to severe use.

■ = Have an authorized dealer perform repairs that involve this component or system.

● = Emissions related components. Have an authorized dealer perform repairs that involve this component or system.

MAINTENANCE

Item		Periodic Maintenance Intervals (Perform at the interval that arrives first)			
		Hour	Calendar	Miles (km)	Remarks
●	Fuel system	100h	12M	500 (800)	Inspect fuel tank, cap, fuel pump and fuel pump relay.
	Spark plug	100h	24M	2000 (3200)	Inspect. Replace if worn or fouled.
■	Engine mounts	100h	12M	1500 (2400)	Inspect condition.
	Exhaust pipe and spark arrestor	100h	12M	500 (800)	Inspect. Clean spark arrestor.
▶	Wiring, fuses, connectors, relays, and cables	100h	12M	1000 (1600)	Inspect wire routing for wear, security. Apply dielectric grease as necessary to connectors subjected to water, mud, etc.

▶ = Severe Use Item. Reduce interval by 50% on vehicles subjected to severe use.

■ = Have an authorized dealer perform repairs that involve this component or system.

● = Emissions related components. Have an authorized dealer perform repairs that involve this component or system.

MAINTENANCE

Item		Periodic Maintenance Intervals (Perform at the interval that arrives first)			
		Hour	Calendar	Miles (km)	Remarks
▶ ■	Wheel bearings	100h	12M	1500 (2400)	Inspect for noise or looseness Replace as necessary.
▶	Safety Belts	100h	12M	2000 (3200)	Visually inspect belts and test latches. Clean latch mechanism more often if used in severe conditions.
	Coolant	200h	24M	4000 (6400)	Change coolant every 2 years if hours or distance interval is not met.
▶	Brake fluid	200h	24M	1000 (1600)	Inspect fluid for color change. Change fluid every two years.

▶ = Severe Use Item. Reduce interval by 50% on vehicles subjected to severe use.

■ = Have an authorized dealer perform repairs that involve this component or system.

● = Emissions related components. Have an authorized dealer perform repairs that involve this component or system.

MAINTENANCE

Item		Periodic Maintenance Intervals (Perform at the interval that arrives first)			
		Hour	Calendar	Miles (km)	Remarks
	Idle condition	--	12M	--	Inspect for proper rpm. See dealer for service if out of spec or erratic.
■	Steering / Wheel Alignment	--	12M	--	Inspect steering system. See dealer for service whenever steering parts or wheel alignment are required.
▶	Foot brake height	--	12M	--	Inspect. Replace brake pads or adjust height as required.

▶ = Severe Use Item. Reduce interval by 50% on vehicles subjected to severe use.

■ = Have an authorized dealer perform repairs that involve this component or system.

● = Emissions related components. Have an authorized dealer perform repairs that involve this component or system.

MAINTENANCE

Maintenance Procedures

Engine oil check

Always check and change the engine oil at the intervals outlined in the Maintenance Schedule.

1. Place the ATV on a level surface.
2. Start the engine and let it idle for (20 ~ 30) seconds. Stop the engine.
3. Wait a short period for the oil to settle.
4. Remove access cover **1**.
5. Unscrew the oil dipstick **2** out and wipe off with a clean cloth.
6. Insert the dipstick back into the dipstick hole, make the dipstick threads contact the hole surface without screwing it.
7. Remove the dipstick again and check the oil level indication. Maintain the oil level between the upper and lower indicators.
8. Reinstall the dipstick into the oil filler hole, hand-tighten it, and reinstall the access cover.

NOTE

Access cover grommets may come loose. Ensure they are in place before reinstalling the cover.

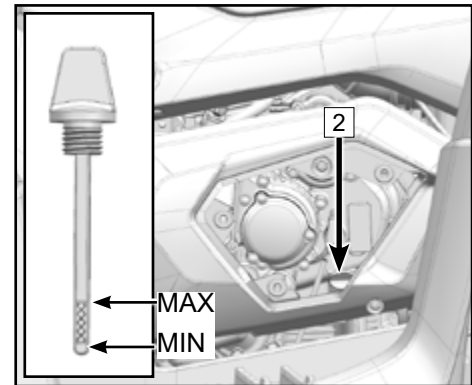
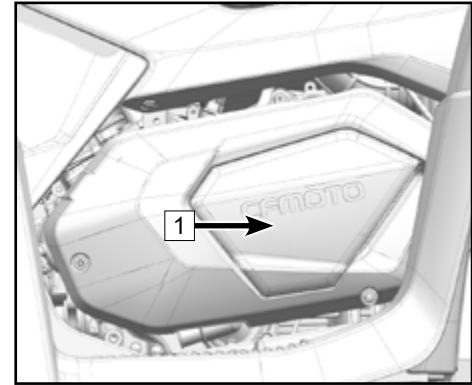

MAINTENANCE

Engine oil change

1. Place the ATV on a level surface.
2. If the engine was running, wait a sufficient period for the oil to settle and cool.
3. Place an oil pan under the engine to collect the used oil.
4. Remove the engine oil drain bolt **1** and drain the oil from the engine.
5. Place a new sealing washer on the engine oil drain bolt, then tighten the drain bolt to the specified torque (25N•m).

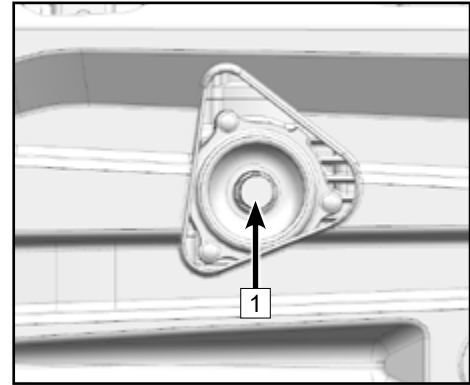

MAINTENANCE

Oil filter replacement

1. Use wrench to unscrew bolts [1]. Then remove cover [2] and remove oil filter [3].

Attention: Confirm cover O-ring [4] is good, then install it into groove of the crankcase correctly.

2. Install new oil filter [3] and use wrench to tighten cover bolts to the specified torque.

NOTE: Cover Bolt [1] Torque: 10 N•m

3. If not already installed, install a new drain bolt washer and tighten the oil drain bolt to the specified torque.

NOTE: Drain Bolt Torque: 25 N•m

4. Add the specified amount of recommended engine oil, and then insert the engine oil dipstick and tighten it.

NOTE:

With oil filter cartridge replacement, oil should be added: 2.96qt (2.8 L).

5. Start the engine and warm it up for several minutes. While warming up, check for oil leaks. If an oil leak is found, turn the engine off immediately and check for the cause.
6. Turn the engine off. Recheck the oil level and correct it if necessary.

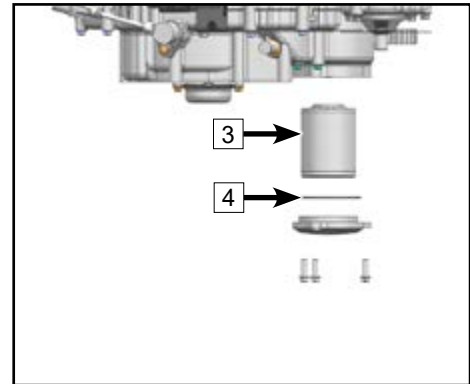
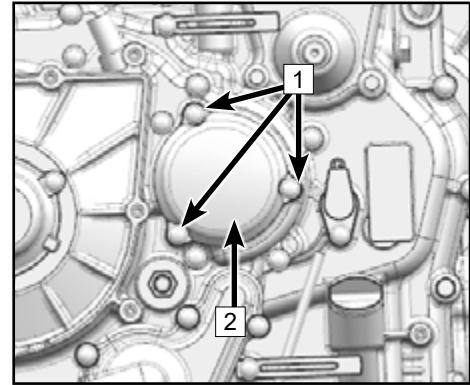

MAINTENANCE

Engine valve train adjustment

The intake and exhaust valve clearances change with use of the vehicle, which can result in improper fuel/air supply or engine noise. To prevent this, the valve clearances must be adjusted according to the maintenance schedule. This adjustment should be performed by a professional service technician. Contact your dealer for service.

NOTE

Engine intake valve clearance (cold engine): 0.002 in ~ 0.006 in. (0.06 mm ~ 0.14 mm)

Engine exhaust valve clearance (cold engine): 0.004 in ~ 0.007 in. (0.11 mm ~ 0.19 mm)

Engine Idle Speed

This vehicle is equipped with an electronic fuel injection system. There are no provisions to adjust engine idle speed. The throttle body is a vital part of the fuel system which requires very sophisticated adjustment, and was set at the factory. If the settings are disturbed, poor engine performance and damage may result. Check engine idle speed for stability and contact your dealer for service if necessary. Contact your dealer in case of an abnormal engine idle condition.

NOTE

Engine idle speed: 1500 rpm \pm 150 rpm (engine at operating temperature)

MAINTENANCE

Gear case oil

The gear cases must be checked for oil leaks before each ride. If an oil leak is found, have your dealer check and repair the ATV.

Rear case oil measurement

Because of its unique design, draining and filling the gear case is required to produce the correct lubricant level. Refer to 'Rear gear case oil change'.

NOTE: Oil filler bolt tightening torque: **18.4 ft-lb. (25 N•m)**.

Rear gear case oil change

1. Place the machine on a level place.
2. Place a container under the front gear case to catch the oil.
3. Remove oil filler bolt and drain bolt 2 at the bottom of rear gear case, and drain used oil.
4. Install the drain bolt and tighten it to the specified torque.

NOTE: Drain bolt tightening torque: **18.4 ft-lb. (25 N•m)**.

5. Fill the rear gear case with oil.

NOTE: Periodic oil change: 6.7 oz (0.2 L)

6. Install the filler bolt and tighten it to the specified torque.
7. Check for oil leaks. If an oil leak is found, check for the cause.

NOTE: Be sure no foreign material enters the rear gear case.

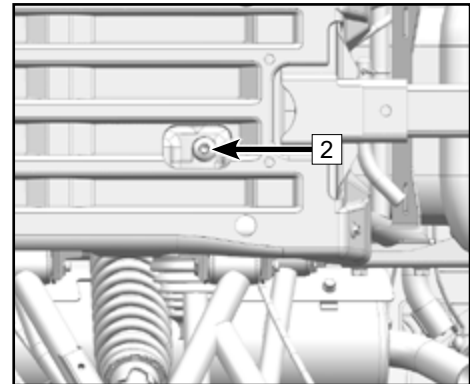
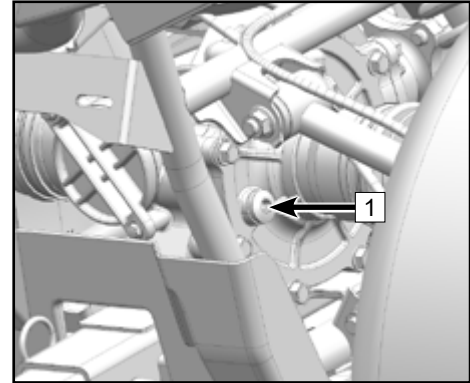

MAINTENANCE

Front gear case oil measurement

Because of its unique design, draining and filling the gear case is required to produce the correct lubricant level. Refer to 'Rear gear case oil change'

NOTE: Oil filler bolt tightening torque: **18.4 ft-lb. (25 N•m).**

Front gear case oil change

1. Place the machine on a level place.
2. Place a container under the front gear case to catch the oil.
3. Remove oil filler bolt and drain bolt 2 at the bottom of front gear case, and drain used oil.
4. Install the drain bolt and tighten it to the specified torque.

NOTE: Drain bolt tightening torque: **18.4 ft-lb. (25 N•m).**

5. Fill the front gear case with oil.

NOTE: Periodic oil change: 7.7 oz (0.23 L)

6. Install the filler bolt and tighten it to the specified torque.
7. Check for oil leakage. If oil leakage is found, check for the cause.

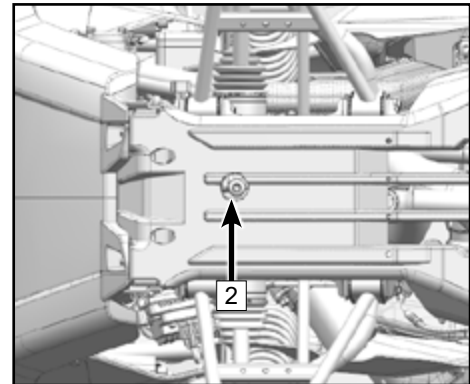
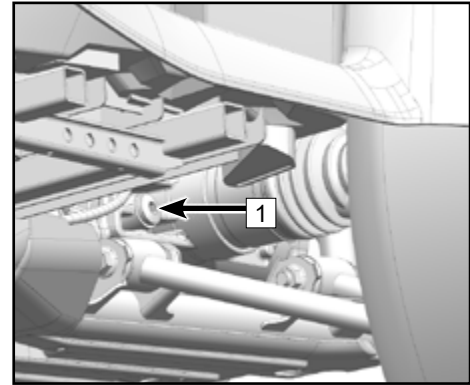

MAINTENANCE

Cooling system

Coolant level check

1. Place the ATV on a level surface.
2. Coolant reservoir **1** is located on the front left of the vehicle. Check the coolant level in the coolant reservoir when the engine is cold as the coolant level will vary with engine temperature.

NOTE:

The coolant should be between the upper **3** and lower **4** limit marks.

3. If the coolant is at or below the lower limit mark, remove the reservoir cap **2**, add coolant to the upper limit mark, install the reservoir cap, and then install the panel.

NOTE:

Lowest capacity of coolant reservoir: 0.21 qt (0.2 L)

⚠ CAUTION

Hard water or salt water is harmful to the engine. You may use soft water if you cannot get distilled water.

⚠ CAUTION

If water is added, have your dealer check the antifreeze content of the coolant as soon as possible. The radiator fan operation is completely automatic. It is switched on or off according to the coolant temperature in the radiator.

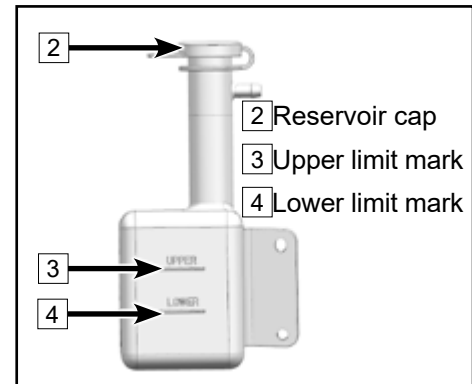
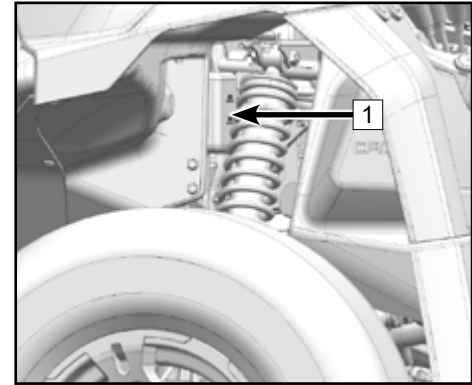

MAINTENANCE

Front access cover

Removal:

Grasp the access cover edge, pull upward to release the grommet pins, then remove the front access cover A by direction of front of vehicle.

Grasp the edge of front top cover B, pull upward to release the grommet pins, then remove the cover B by direction of front of vehicle.

Install: Insert the cover tabs into the corresponding holes on the body, then align the grommet pins and press down.

NOTE:

Maintain easy removal cover by applying thin lubricant to the grommet pins occasionally.

Remove front access cover, then inspection and maintenance can be done for the radiator assy, reservoir tank, relay box, and fuse.

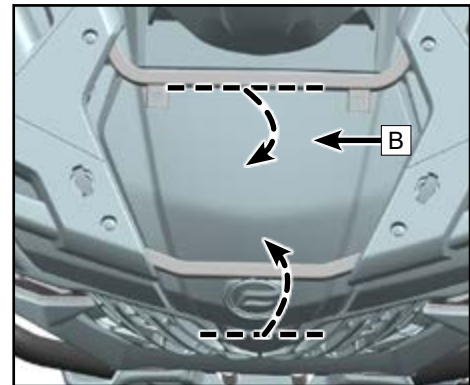
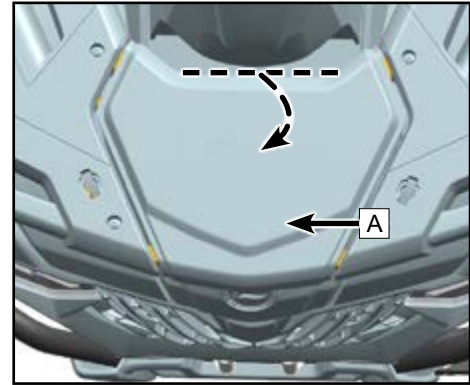

MAINTENANCE

Changing the coolant

⚠ CAUTION

After running the engine, never remove the radiator cap immediately. Wait for the engine to cool down before removing the radiator cap. Hot coolant can cause serious burns.

1. Place the ATV on a level surface.
2. Remove the front access cover.
3. Remove the radiator cap [2].
4. Remove the coolant reservoir cap [1].
5. Place a container under the engine, and then remove:
 - The small engine left cover [3].
 - The engine left cover [4].
 - The coolant drain bolt [5].

Coolant will begin to drain from the system

6. Disconnect the hose from the coolant reservoir, and drain the coolant into a container.
7. After draining the system, thoroughly flush the system with clean tap water. Allow the water to drain completely from the coolant drain.

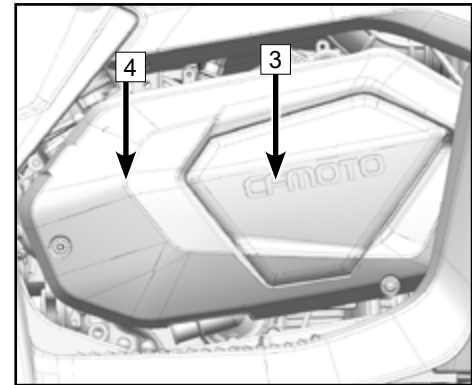
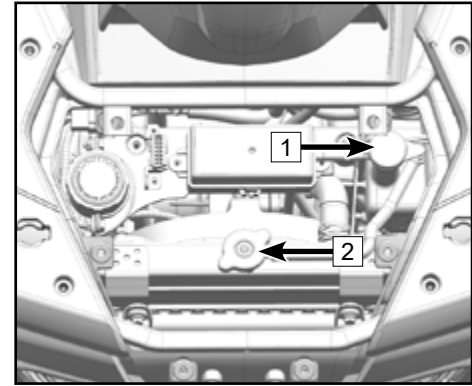

MAINTENANCE

8. Replace the coolant drain bolt washer if it is damaged, then install and tighten the coolant drain bolt, but do not torque to specification.
9. Reinstall the coolant reservoir hose.
10. Fill the recommended coolant into the radiator until it is full.

NOTE

When filling coolant, at the same time loosen the coolant drain bolt **5** to draw out potential air bubbles inside the coolant hose until coolant flows out, then tighten the drain bolt to 7.3 ft-lb. (10 N•m).

11. Install the radiator cap.
12. Start the engine and let it idle for several minutes. Stop the engine and allow it to cool. Check the coolant level in the radiator. If it is low, add more coolant until it reaches the top of the radiator. Repeat as necessary.
13. Fill the coolant reservoir with coolant up to the upper limit.
14. Install the coolant reservoir cap and check for coolant leaks. If any leaks are found, have your dealer check the cooling system.
15. Reinstall:
 - The engine left cover. Tighten the fasteners to 7.3 ft-lb. (10 N•m).
 - The small engine left cover
 - The front access cover

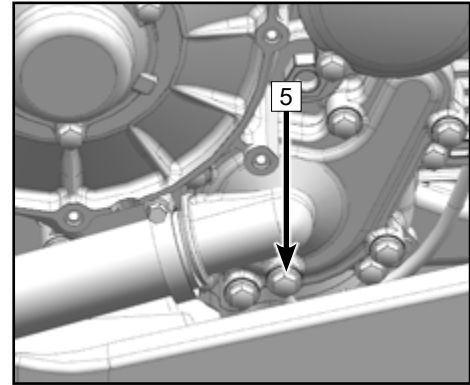

MAINTENANCE

NOTE

Recommended antifreeze:

Any high quality ethylene glycol antifreeze containing corrosion inhibitors for aluminum engines. CFMOTO recommended coolant freeze protection level: -35°C.

Antifreeze and distilled water mixing ratio: 1:1

Total Coolant Capacity (except coolant reservoir): 2.3 qt. (2.18 L)

Coolant Change (except coolant reservoir): 2.22 qt. (2.1 L)

Coolant reservoir capacity: 0.21 qt. ~ 0.4 qt. (0.2L ~ 0.38 L)

(Lower mark: 0.2 L / Upper mark: 0.38 L)

 WARNING
--

If replace with different coolant, please contact with your dealer to out completely the residual coolant. Different coolant mixture may lead to engine failure.
--

Cleaning

Cleaning the external surfaces of the radiator if it is covered with mud or debris will ensure it continues to efficiently cooling the engine. Use only low pressure water to clean the radiator. High pressure washers can damage components. Ensure that the water can flow freely through the radiator fins. This is a sign that cooling air will be allow to pass through.

MAINTENANCE

Axle dust boots

Check the protective boots **1** for holes or wear. If any damage is found, have them replaced by your dealer.

Rear :

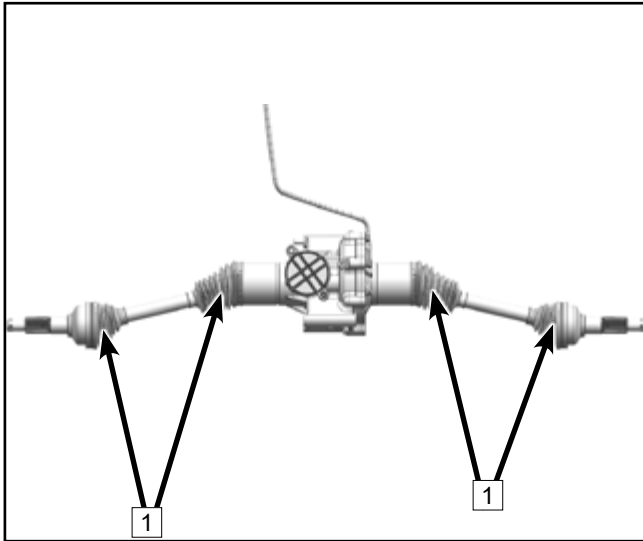

Front:

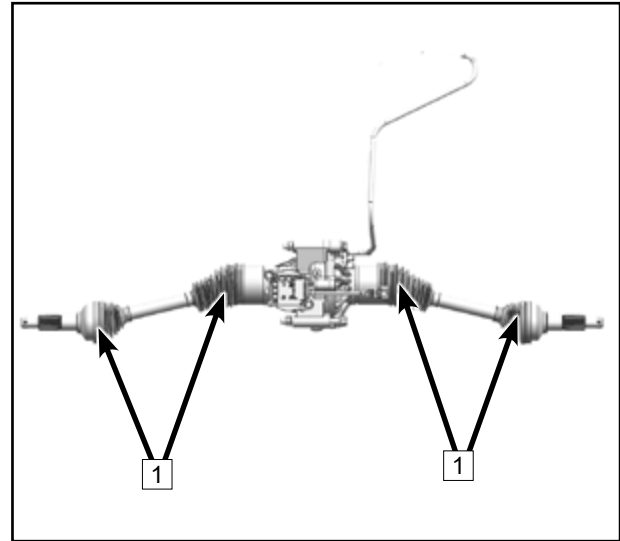

MAINTENANCE

Spark plug inspection

To access the spark plug, the following components must be removed:

Left Deco Panel

Remove the expansion screws **1**

Remove the bolt **2**

Remove the cover **3**;

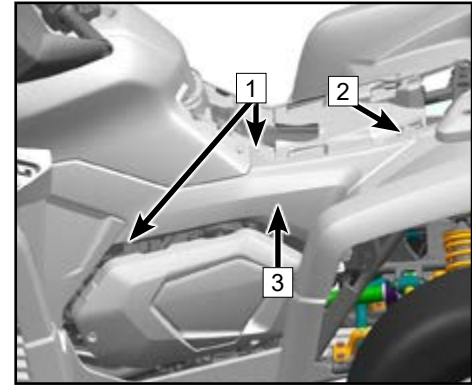

Shifter Cover

Remove the screw **4**;

Remove the bolts **5**;

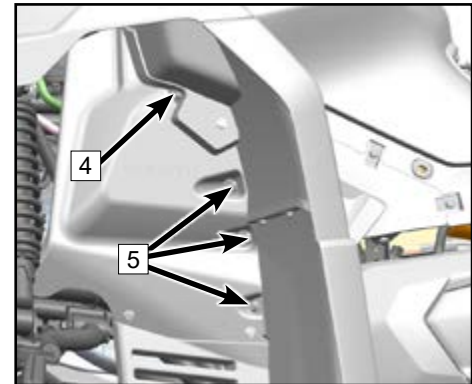

MAINTENANCE

Remove the cover **6**;

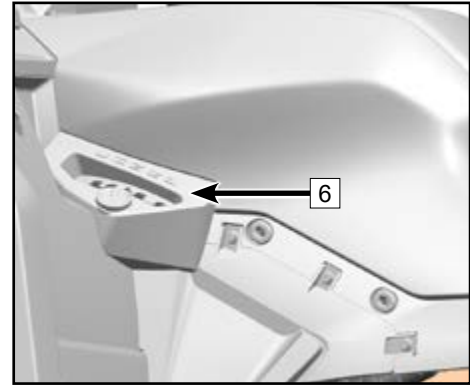

Lower Side Cover

Remove the bolts **7**;

Remove the left lower side cover **8**;

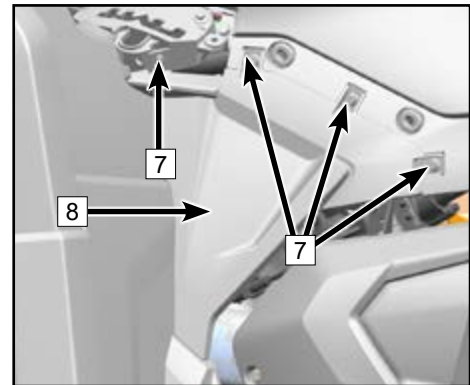

MAINTENANCE

Removal

Remove the spark plug cap.

Use the spark plug wrench in the tool kit to remove the spark plug.

Inspection

The spark plug is an important engine component and is easy to inspect. The condition of the spark plug can indicate the condition of the engine. The ideal color on the white insulator around the center electrode is a medium-to-light tan color for a ATV that is being ridden normally. Do not attempt to diagnose such problem yourself. Instead, take your ATV to a dealer. You should periodically remove and inspect the spark plug because heat and deposits will cause the spark plug to slowly break down and erode. If electrode erosion becomes excessive, or if carbon and other deposits are excessive, you should replace the spark plug with the specified plug.

NOTE: Specified spark plug: DCPR8E (NGK)

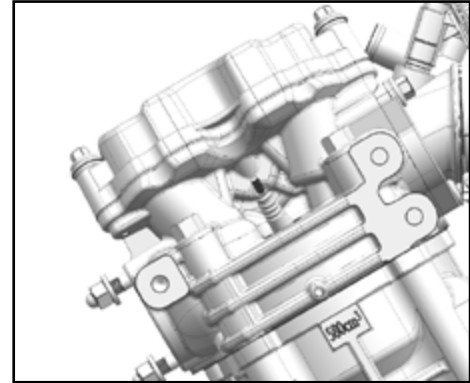

MAINTENANCE

Measure the electrode gap with a thickness gauge, and if necessary, adjust the gap to specification.

NOTE: Spark plug gap [a]: 0.8 mm ~ 0.9 mm

Installation

1. Clean the gasket surface. Wipe off any grime from the threads.
2. Install spark plug and tighten to specified torque.

NOTE: Spark Plug Torque: 14.8 ft-lb. (20 N•m)

If a torque wrench is not available when you are installing a spark plug, a good estimate of the correct torque is 1/4 to 1/2 turn past finger tight. Have the spark plug tightened to the specified torque as soon as possible.

3. Install the spark plug cap.
4. Install the panels and shifter cover.

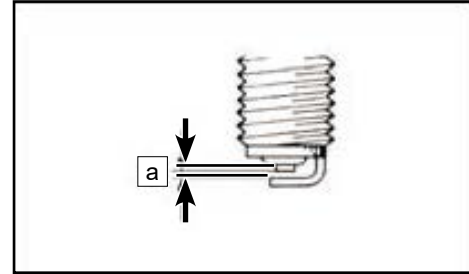

MAINTENANCE

Spark plug removal to expel water from the engine

If water has been ingested into the engine, it is important to remove the water as soon as possible by removing the spark plug and using the starter system to rotate the engine for a short period to expel water out of the cylinder. Verify that the air box has been drained of water before attempting to expel water.

CAUTION

Major engine damage can result if the vehicle if water is ingested into the engine. Have the vehicle serviced by your dealer promptly if your vehicle becomes immersed or stalls in water that exceeds the footrest level. It is important to contact your dealer for service before starting the engine if water has been ingested. Water inside the engine can cause a 'hydraulic lock' effect that can damage the starter and engine components. The engine oil should be checked for water contamination. Drain and refill with new engine oil if water is found in the crankcase.

MAINTENANCE

Air filter element

There is a check hose [1] at the bottom of the air filter housing. If dust or water can be viewed in this hose, empty the hose and clean the air filter housing thoroughly. If the vehicle was submerged, please contact your local dealer to check for water inside the engine crankcase.

Air filter maintenance

1. Remove the seat.
2. Remove the upper protector of air filter [2].
3. Remove the cover spring clips [3] and bolt [4].
4. Remove the filter housing cover [5].
5. Loosen the air filter clamp [6] and remove the foam pre-filter [7].
6. Remove the foam pre-filter [7] from the air filter.
7. Wash the foam pre-filter gently with soap and water, and allow it to completely dry.
8. Inspect the paper air filter and verify it is okay to reinstall. Softly brush off accumulated dust if necessary. Install a new filter as necessary.

CAUTION

Do not use liquid to wash paper filter element.

9. Install the pre-filter onto the air filter. Apply a thin film of

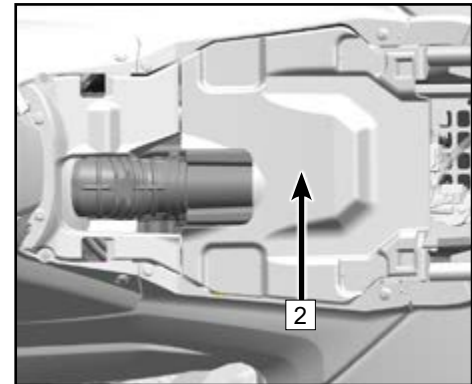
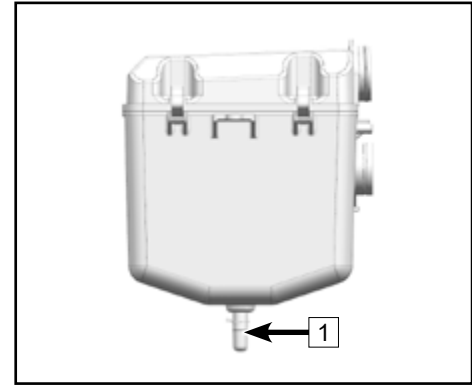

MAINTENANCE

lubricant on the inside diameter of the air filter rubber seal.

10. Install the air filter and clamp onto the air filter housing inlet. Tighten the clamp securely.
11. Reinstall the air filter housing cover and spring clips. Verify the cover is installed correctly and is sealing properly.
12. Reinstall the decorative cover assembly. Ensure the grommets are engaged and secure.

NOTE

The air filter must be checked and replaced more often if the machine is operated in extremely dusty areas or if it becomes wet. Each time air filter maintenance is performed, check the air inlet to the air filter box for obstructions, the fittings of the air filter housing rubber joint, throttle body, and manifold for an airtight seal. Check that all fittings are tightened securely to avoid the possibility of unfiltered air entering the engine.

CAUTION

Do not start engine without air filter element. Non-filtered air will enter into the engine and cause engine wearing and damage. In addition, driving without air filter will also decrease performance and engine overheating.

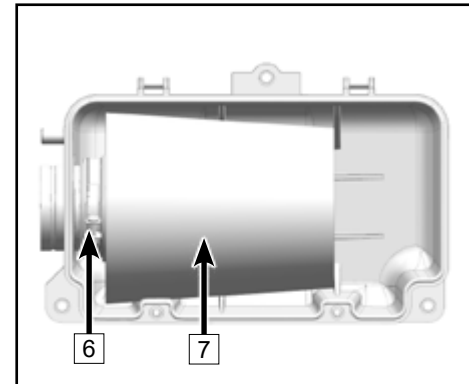
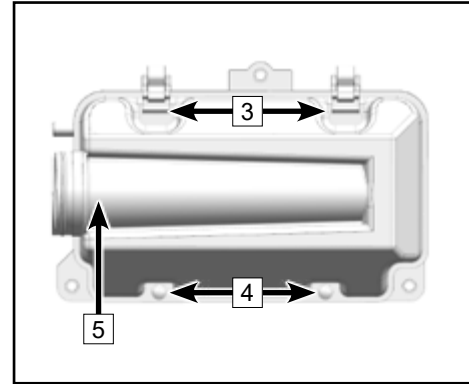

MAINTENANCE

Drying the air filter housing after submersion

If water has been ingested into the air filter housing, Drain the air filter housing, remove the air filter, and thoroughly dry the components. Do not use compressed air. Contact your dealer if vehicle performance issues exist.

CAUTION

Do not operate the engine without an air filter element. Unfiltered air will enter into the engine and cause engine wear and damage. Driving without an air filter will also decrease performance and can lead to engine overheating.

CAUTION

Major engine damage can result if the vehicle if water has been ingested into the air filter housing, and engine. Have the vehicle serviced by your dealer promptly if your vehicle becomes immersed or stalls in water that exceeds the footrest level. It is important to contact your dealer for service before starting the engine, as water may have been ingested in the air box and engine.

MAINTENANCE

Spark Arrestor

Clean spark arrestor while muffler and exhaust are in normal temperature.

1. Remove nut **1**.
2. Remove spark plug arrestor **2** from muffler.
3. Tap the tailpipe lightly, and then use a wire brush to remove any carbon deposits **3** from the spark arrestor portion of the tailpipe.
4. Insert the tailpipe into the muffler and align the bolt holes.
5. Install and tighten the bolts.

⚠ WARNING

When cleaning the spark arrestor: Always let the exhaust system cool prior to touching exhaust components. Do not start the engine when cleaning the exhaust system.

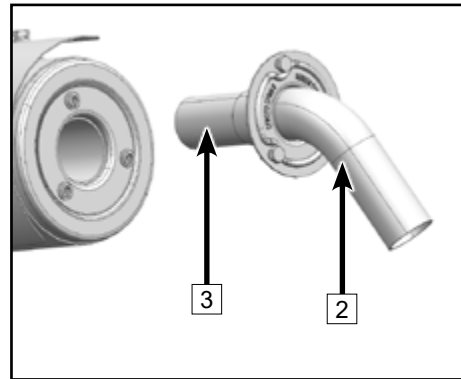
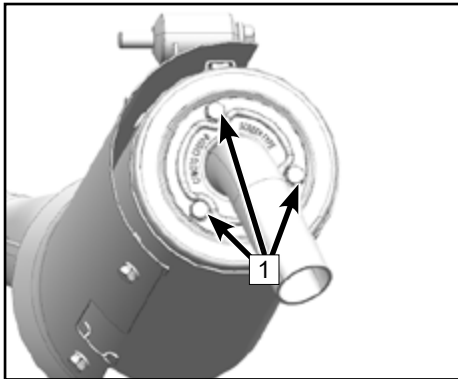

MAINTENANCE

CVT air-outlet check hose

If dust or water can be viewed in this hose **1**, empty the hose and clean or drain the CVT housing. If the vehicle was submerged, contact your local dealer to check the CVT housing and components thoroughly.

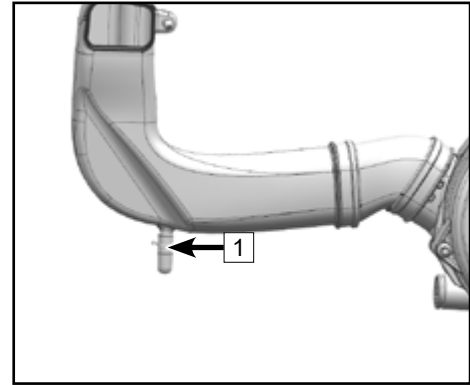

CVT cover drain bolt

If the vehicle was submerged in water deep enough that water entered the CVT housing, remove the drain bolt **2**. to drain the water from the case.

⚠ CAUTION

If water drains from the V-belt case after removing the bolt, have your dealer inspect the ATV, as the water may have affect the CVT system and other engine parts.

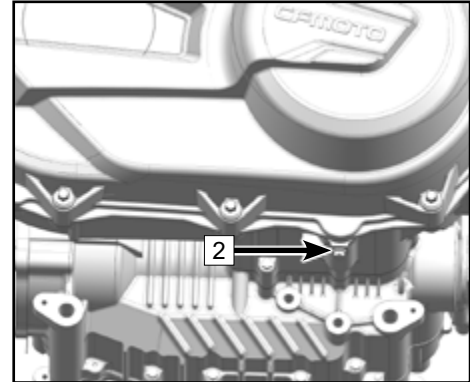

MAINTENANCE

Throttle freeplay adjustment

Check the throttle freeplay at regular intervals.

NOTE

Check the engine idling speed after adjusting throttle lever freeplay.

1. Loosen nut **1**.
2. Turn adjustment nut **2** to lever travel: **a** = 3 mm ~ 5 mm.
3. Fasten nut **1**.

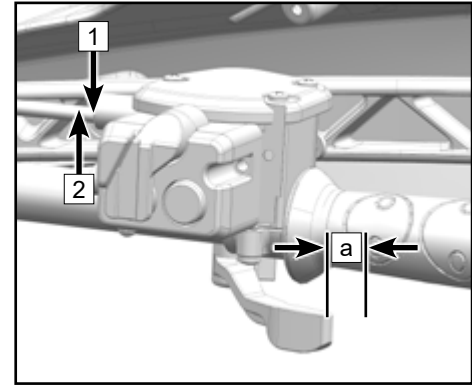

Brake pad inspection

Check the brake pads **1** for damage and wear. If the pad thickness **a** is less than 0.09 in. (2.3mm) or the disc thickness **b** is less than .157 in. (4.0mm), have your dealer replace them. Replacement of brake components requires professional knowledge. These procedures should be performed by your dealer.

NOTE:

The wheels need to be removed to check brake pads.

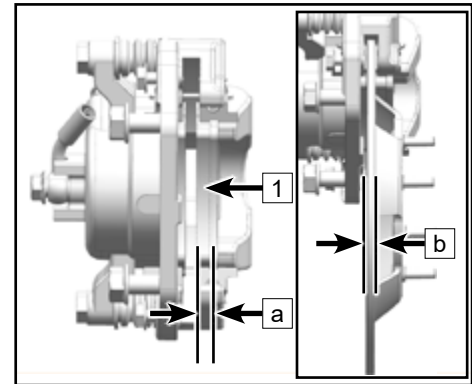

MAINTENANCE

Brake system inspection

Check the fluid level **1**.

Insufficient brake fluid may let air enter the brake system, possibly causing the brakes to become ineffective. Before riding, check that the brake fluid is above the lower level and replenish when necessary. The front brake fluid master cylinder reservoir is located on the right side of the handlebar. The foot brake fluid master cylinder reservoir is located under the front access cover.

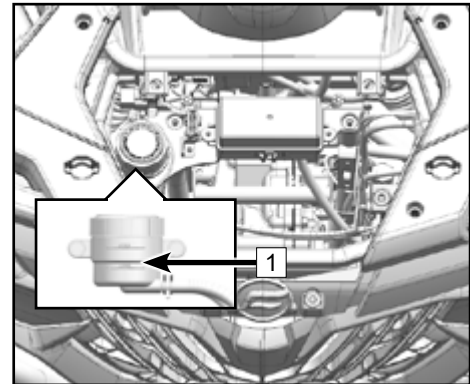
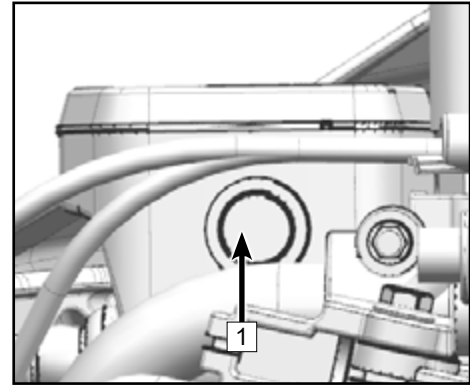

MAINTENANCE

Inspect brake fluid level

Observe these precautions:

1. When checking the front brake fluid level, make sure the master cylinder reservoir is level by turning the handlebar until the steering is centered and the wheels are pointed forward.
2. Use only the designated quality brake fluid. Otherwise, the rubber seals may deteriorate, causing leakage and poor brake performance.

NOTE

Recommended brake fluid: DOT 4.

3. Refill with the same type of brake fluid. Mixing fluids may result in a harmful chemical reaction and lead to poor brake performance.
4. Be careful that water does not enter the master cylinder reservoir when refilling. Water will significantly lower the boiling point of the fluid and may result in vapor lock.
5. Brake fluid may deteriorate painted surfaces or plastic parts. Always clean up spilled fluid immediately.
6. Have your dealer check the cause if the brake fluid level goes down.

MAINTENANCE

Brake fluid change

Complete fluid replacement should be done only by trained service personnel. Have your dealer replace the following components during periodic maintenance or when they are damaged or leaking.

- Replace the brake hoses every four years.

Front lever free play a

The front brake lever should have a free play at the lever end. If not, contact your dealer to check the brake system.

⚠ DANGER (After servicing):

- Make sure the brakes operate smoothly and that the free play is correct.
- Make sure the brakes do not drag. Make sure the brakes are not spongy.
- All air must be bled from the brake system. Servicing of brake components requires professional knowledge. These procedures should be performed by your dealer.

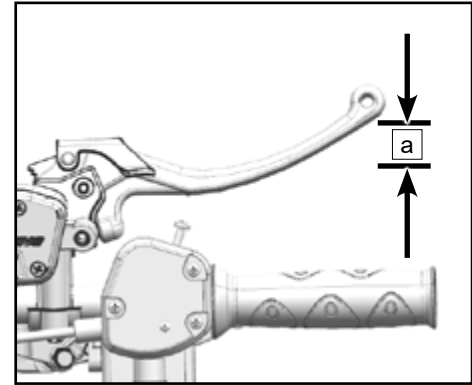

MAINTENANCE

Parking brake

When parking, stop the engine and grasp tightly the right hand brake, press foot brake at the same time, then press the hydraulic parking brake **1** by left hand.

WARNING

Operating the ATV while the parking brake is engaged could result in an accident and serious injury or death.

Always check to be sure the parking brake is disengaged before operating.

Important Safeguards

The parking brake may relax if left on for a long period of time. Always block the wheels to prevent rolling. Never depend on the parking brake alone if the ATV/Quadricycle is parked on a hill. Always block the wheels on the downhill side of the ATV/Quadricycle to prevent rolling. Another option is to park the ATV/Quadricycle in a sidehill position.

DANGER

The RH parking brake must not be used for braking during operation.

RH parking brake

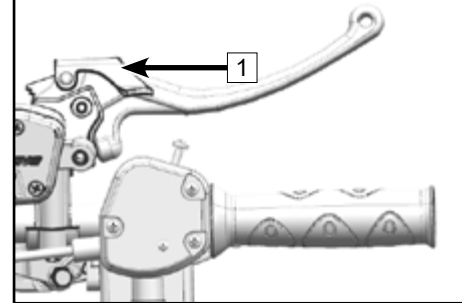

MAINTENANCE

Foot brake pedal height adjustment

NOTE

The top of the brake pedal should be positioned 95 mm ~ 100 mm above the top of the footrest. If it is not, have your dealer to adjust it.

⚠ DANGER

After servicing:

- Make sure the brakes operate smoothly and that the freeplay is correct.
- Make sure the brakes do not drag.
- All air must be bled from the brake system. Replacement of brake components requires professional knowledge. These procedures should be performed by your dealer.

Foot brake light switch

Check switch assembly or cable is properly fixed in case of brake light failure.

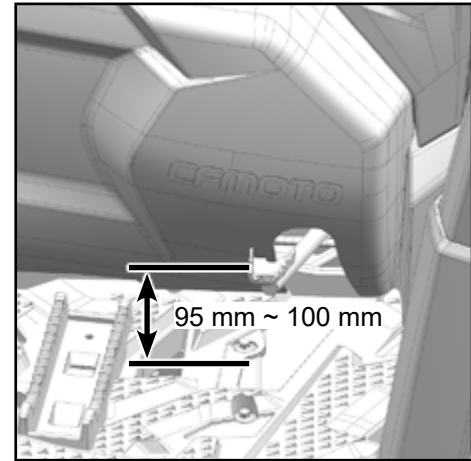

MAINTENANCE

Cable inspection and lubrication

⚠ WARNING

Inspect cables frequently. Replace damaged cables. Lubricate the inner cables and the cable ends. If the cables do not operate smoothly, ask your dealer to replace them.

NOTE

Recommended lubricant: SAE 10W/30

Suspension Pivot Lubrication

Lubricating rear stabilizer bar.

Add lubricating grease into grease nipple **1** with oil gun until oil outflowing from bushing.

NOTE

There are 2 grease nipples on rear stabilizer bar, they are symmetrical in left and right.

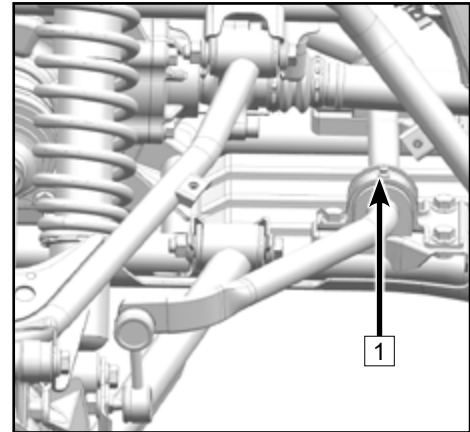

MAINTENANCE

Tire pressure

Inspect the tire pressure before operation:

Front: 6.5 psi (45 kPa)

Rear: 6.5 psi (45 kPa)

Tread depth

Inspect the tread depth regularly and replace the tires if the minimum tread depth is less than:

Minimum tread depth: 3/32 in. (3.0 mm)

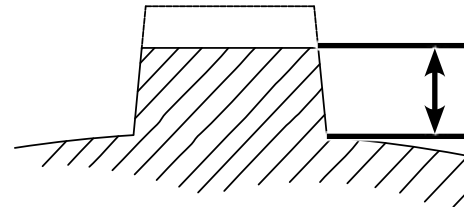
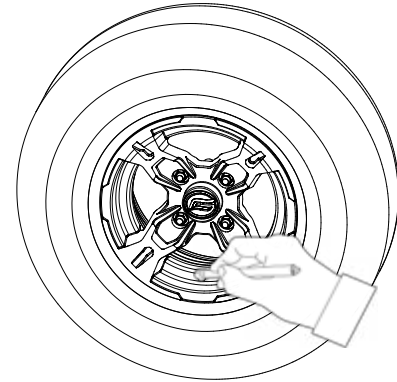

MAINTENANCE

Battery

This machine is equipped with low maintenance battery which is located under the seat. Therefore, it is not necessary to check the electrolyte or add distilled water in the battery. If the battery seems to have discharged, consult your dealer.

NOTE

Battery specification: 12V 30Ah

 WARNING
--

Do not try to remove the sealing caps of the battery cells. You may damage the battery.

 DANGER

Avoid contact with skin, eyes or clothing. Always shield eyes when working near batteries. Keep out of reach of children.

Antidote:

EXTERNAL: Flush with water. INTERNAL: Drink large quantities of water or milk. Follow with milk of magnesia, beaten egg or vegetable oil. Get prompt medical attention.

EYES: Flush with water for 15 minutes and get prompt medical attention. Keep batteries away from sparks, flames, cigarettes or other sources of ignition. Ventilate when charging or using in a closed space.

MAINTENANCE

Battery maintenance guidelines:

- If the vehicle will not be used for a month or longer, remove the battery and store it in a cool, dry place. Completely recharge the battery before reinstallation.
- A special battery charger (constant low voltage/ampere) is required for recharging low maintenance batteries. Using a conventional battery charger may shorten the battery life.
- Always make sure the cable connections are the correct polarity when reinstalling the battery. RED ('+' positive) / Black ('-' negative). Always disconnect the RED ('+' positive) cable last during removal, and reconnect it first during installation.
- Corroded battery connections can be cleaned with a mixture of baking soda and water.

MAINTENANCE

Battery Disassembly

Turn off all electrical parts and the engine before disassembly.

Disassembly (The L model)

Remove the passenger and operator seats.

Remove the expansion screws [1].

Remove the deco panel [2].

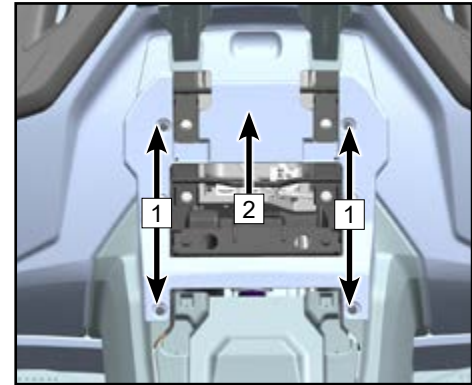

Remove bolt [3].

Remove the rear seat mounting bracket [4].

Remove the belt [5] and electrode cover [6].

Remove the fixing bolt of battery negative wire together with the wire.

Remove the fixing bolt of battery positive wire together with the wire.

Take out the battery [7].

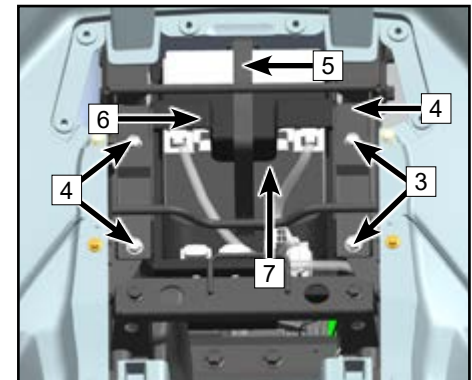

MAINTENANCE

Assembly (The L model)

Mount the battery [1] in place.

Mount the positive wire onto the battery positive bolt.

Mount the negative wire onto the battery negative bolt.

Mount the belt [2] and electrode cover [3].

Mount the rear seat mounting bracket [4].

Mount the bolt [5].

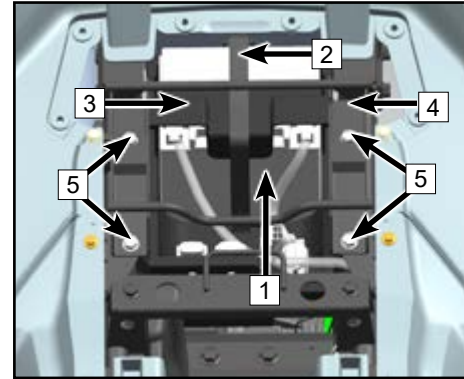

Mount the deco panel [6].

Mount the expansion screws [7].

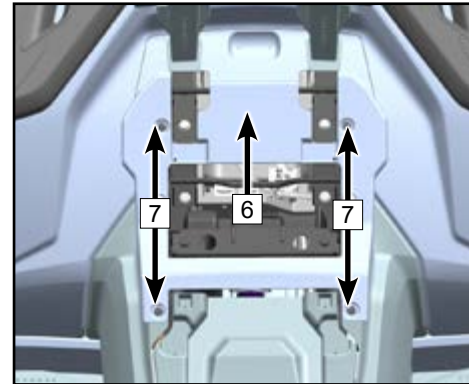

MAINTENANCE

Disassembly (The S model)

Remove the expansion screws [1].

Remove the deco panel [2].

Remove the bolt [3].

Remove the front seat assembling bracket [4].

Take out the belt [5] and electrode protector [6].

Remove the fixing bolt of battery negative wire together with the wire.

Remove the fixing bolt of battery positive wire together with the wire.

Take out the battery [7].

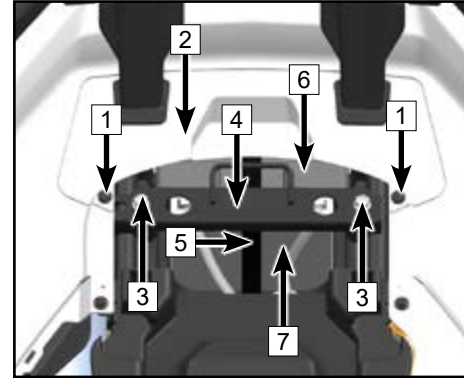

Assembly (The S model)

Mount the battery [1] in place.

Mount the positive wire onto the battery positive bolt.

Mount the negative wire onto the battery negative bolt.

Mount the belt [2] and electrode cover [3].

Mount the rear seat mounting bracket [4].

Mount the bolt [5].

Mount the deco panel [6].

Mount the expansion screws [7].

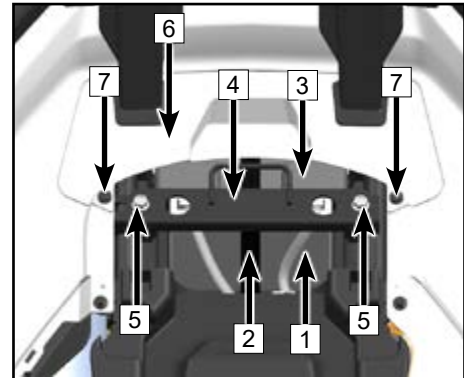

MAINTENANCE

Fuse and Relay replacement

1. Relay / Fuse box **1** is located under the front access cover. Main fuse 30A **2** and EPS fuse 40A **3** are located under the seat.
2. If a fuse is blown, turn off the main switch and install a new fuse of the specified amperage. Test by turning on main power and switches. If the fuse immediately blows again, consult your dealer.

⚠ CAUTION
Always use a fuse of the specified rating.
Never use conductive material in place of the proper fuse.

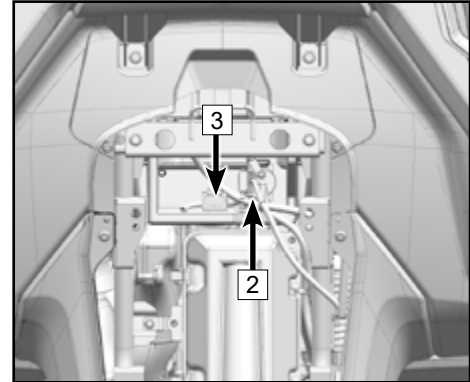
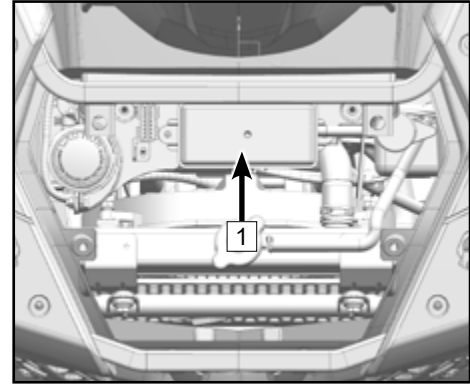

MAINTENANCE

Relay / Fuse Box

For vehicle without turning light

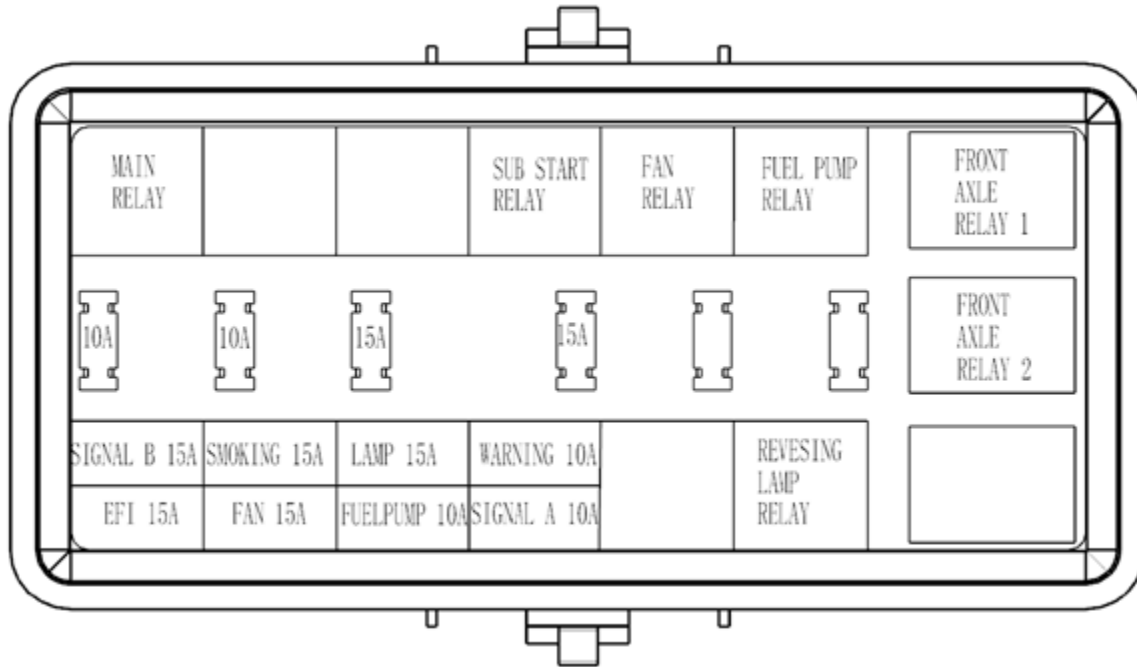

MAINTENANCE

Relay / Fuse Box

For vehicle with turning light

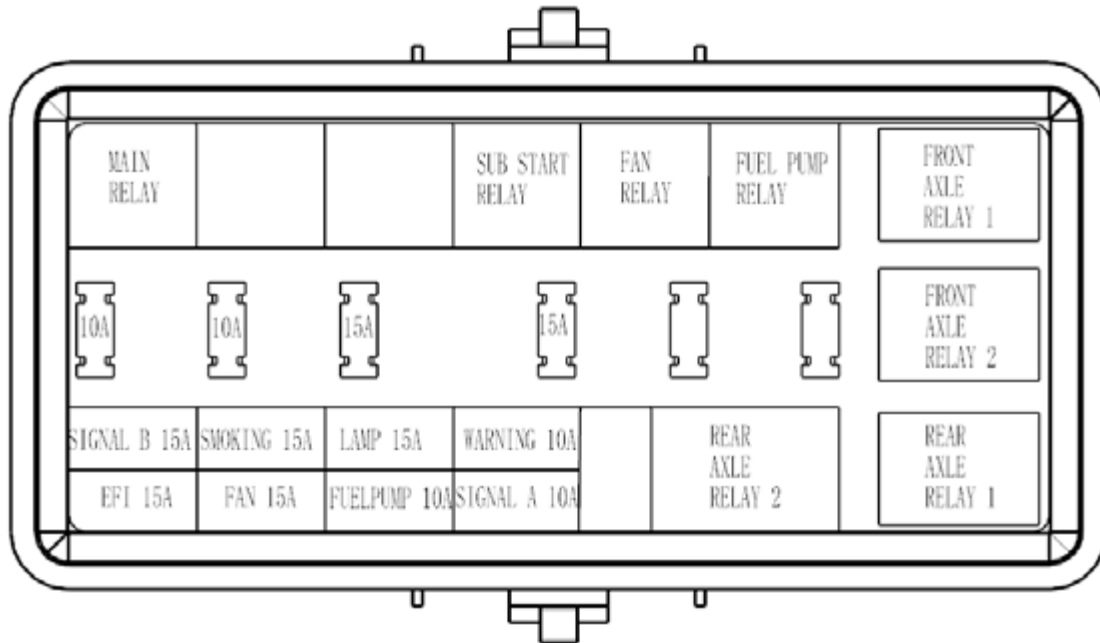

MAINTENANCE

WARNING

To prevent accidental short-circuit, turn off the main switch when checking or replacing a fuse.

Headlight bulb replacement

NOTE:

Both headlight and taillight assy are LED lights, which cannot be repaired if damaged or failed. Please have your dealer replace the entire assembly when the LED light is damaged or failed.

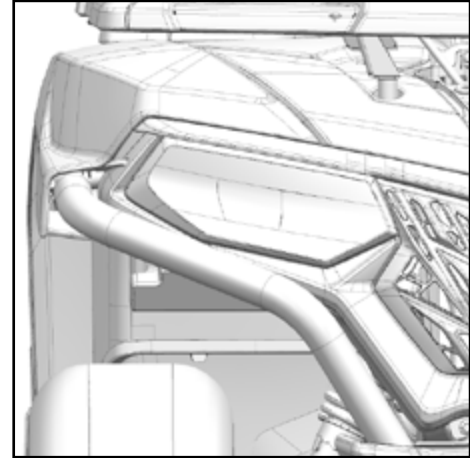

MAINTENANCE

Headlight beam adjustment

⚠ WARNING

It is advisable to have your dealer make this adjustment. Turn the adjusting screws can raise or lower the beam.

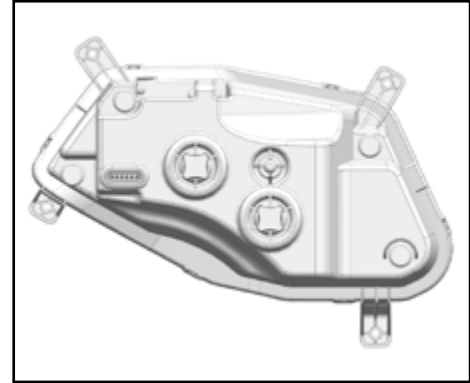

Tail/brake light replacement:

Tail/brake light bulb is LED, it can not be replaced separately. Replace the whole light as necessary.

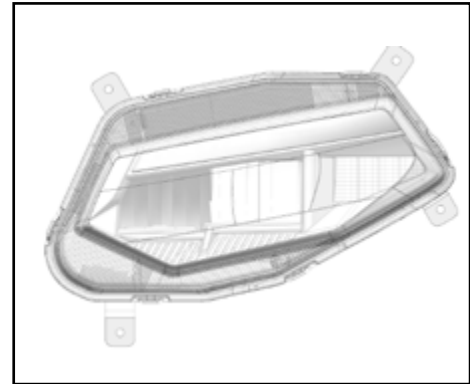

MAINTENANCE

Front and rear suspension adjustment

Standard shock absorber

The spring preload can be adjusted to suit the rider's weight and riding conditions.

NOTE

When adjusting the rear shock absorbers, the rear wheels need to be removed.

Adjust the spring preload as follows. To increase the spring preload, turn the adjusting ring **1** in direction **a**.

To decrease the spring preload, turn the adjusting ring **1** in direction **b**.

NOTE

A special wrench **3** (if not supplied in tool kit) can be obtained at a dealer to make this adjustment.

Standard preload position: **C**

A- Minimum (soft)

G- Maximum (hard)

NOTE

Always adjust the shock absorbers on the left and right sides to the same setting.

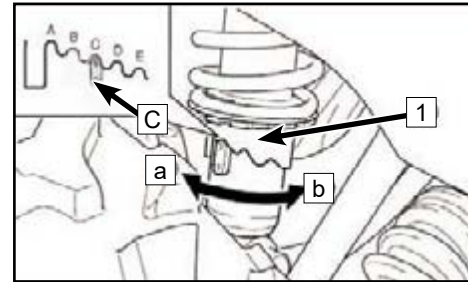

MAINTENANCE

WARNING

If your vehicle becomes immersed, major engine damage can result if the machine is not thoroughly inspected. Take the vehicle to your dealer before starting the engine. For example, if engine is not properly handled after immersion, starting will damage the engine.

Fuel Evaporation System (EVAP)(If equipped)

Your vehicle contains a fuel evaporation system (EVAP) that prevents fuel vapors from entering the atmosphere from the fuel tank and fuel system. Never modify any part of this system, which will violate fuel evaporation emission regulations.

During routine maintenance, visually inspect all connections for leaks and blockage, and inspect the hoses for kinks or damage.

No other maintenance is necessary. Contact your dealer if repair is required.

NOTE: Information applies only to vehicles equipped with a fuel evaporation system.

CLEANING & STORAGE

Cleaning & Storage

Cleaning the ATV

Keeping your ATV clean will not only improve its appearance, but it can also extend the life of various components. With a few precautions, your ATV can be cleaned much like an automobile.

Washing the ATV

The best and safest way to clean your ATV is with a garden hose and a pail of mild soap and water. Use a professional type washing mitt, cleaning the upper body first and the lower parts last. Rinse with water frequently and dry with a chamois to prevent water spots.

NOTE

If warning and safety labels are damaged, contact your dealer for replacement.

CFMOTO does not recommend the use of a high pressure type car wash system for washing your ATV. If a high pressure system is used, exercise extreme care to avoid water damage to the wheel bearings, transmission seals, body panels, brakes, warning labels, air filter intake system and electric system, etc. Water is not allowed to enter into air filter.

NOTE

Grease all fittings immediately after washing, and allow the vehicle to run for a while to evaporate any water that may have entered the engine or exhaust system.

CLEANING & STORAGE

Waxing the ATV

Your ATV can be waxed with any non-abrasive automotive paste wax. Avoid the use of harsh cleaners since they can scratch the body finish.

 CAUTION
--

Certain products, including insect repellents and chemicals, will damage plastic surfaces. Use caution when using these products near plastic surfaces.

Perform repairs

Make necessary repairs to your vehicle before storing to prevent further damage the next time you operate it.

Check the tires

Inspect the tire treads and overall condition. Set the tires to the specified air pressure.

CLEANING & STORAGE

Oil and Filter

Warm the engine, then stop the engine and change the oil and filter.

Air Filter/ Air Box

Inspect and clean or replace air filter. Clean the air box and drain the sediment tube.

Check fluid levels

Inspect the following fluid levels and change if necessary:

- Front gear case
- Rear gear case
- Brake fluid (change every two years or as required if fluid looks dark or contaminated)
- Coolant (change every two years or as required if coolant looks contaminated)
- Fuel Level (add fuel stabilizer according to the product label directions)

Stabilize the fuel

Fill the fuel tank with fresh fuel that has been treated with fuel stabilizer according to the product label directions. Do not allow untreated fuel to remain in the tank longer than 30 days, as the fuel begins to degrade and can cause damage to the fuel system components.

Battery storage

Remove the battery from the vehicle and ensure that it is fully charged before placing it in storage. Protect the battery from freezing temperatures, which can damage the battery.

CLEANING & STORAGE

Lubricate

Inspect all cables and lubricate with cable lubricant according to the product label directions. Grease the vehicle pivot points with all season grease.

'Fog' the engine

1. Remove the left side panel to access the spark plug.
2. Remove the spark plug, rotate the piston to the bottom of its stroke and pour approximately 2 oz.(15 mL ~ 20 mL) of engine oil into the opening.

NOTE

Do this carefully! If you miss the spark plug hole, oil will drain from the spark plug cavity, and appear to be an oil leak. To access the spark plug hole, use a section of clean hose and a small plastic squeeze bottle filled with the pre-measured amount of oil.

3. Reinstall the spark plug. Torque the spark plug to specification.
4. Turn engine over several times slowly. Oil will be forced in and around the piston, piston rings and the cylinder will be coated with a protective film of fresh oil.
5. Reinstall the spark plug cap and side panel.

NOTE

Starting the engine during the storage period will disturb the protective film created by fogging. Corrosion could occur. Never start the engine during the storage period.

CLEANING & STORAGE

Engine Anti-Freeze

Test engine coolant strength and change if necessary. Coolant should be replaced every two years.

Storage Area/Covers

Set the tires to specified air pressure and support the ATV with tires 30 mm ~ 40 mm off the ground. Be sure the storage area is well ventilated and cover the machine with a ATV cover.

NOTE

Do not use plastic or coated materials. They do not allow enough ventilation to prevent condensation, and may promote corrosion and oxidation.

CLEANING & STORAGE

Transporting the ATV

Follow these procedures when transporting the vehicle:

- Turn off the engine and remove the key to prevent loss during transporting.
- Ensure the fuel cap is installed correctly and secure.
- Ensure the seat is installed correctly and secure.
- Place the gear into any position except the parking position, and block the front and rear wheels to prevent the vehicle from moving.
- Secure both the front and rear of the vehicle frame to prevent the vehicle from sliding or moving during transport.

 CAUTION
--

Never transport the ATV with the gear selector in Park position. Transmission damage will result.

VEHICLE DIAGNOSIS

Vehicle Issue Diagnosis

This section is intended to guide an average owner to simple items that could cause operating problems. Diagnosis of vehicle issues may require the experience of a dealership technician. Please contact your dealer if a solution is not apparent.

Engine doesn't turn over

Fail Reason	How To Avoid Failure
Poor engine performance.	Check for fouled plugs or foreign material in gas tank, fuel lines, or throttle. Contact your dealer for service.
Tripped circuit breaker	Reset the breaker or replace the fuse
Low battery voltage	Recharge battery to 12.8 Vdc
Loose battery connections	Check all connections and tighten
Loose solenoid connections	Check all connections and tighten

Engine Pings or Knocks

Fail Reason	How To Avoid Failure
Poor quality or low octane fuel	Replace with recommended fuel
Incorrect ignition timing	See your dealer
Correct spark plug gap or heat range	Set gap to specs or replace plugs

VEHICLE DIAGNOSIS

Engine Stops or loses power

Fail Reason	How To Avoid Failure
Overheated engine	Clean radiator screen and core Clean engine exterior See your dealer

Engine Turns Over, Fails to Start

Fail Reason	How To Avoid Failure
Out of Fuel	Refuel
Clogged fuel valve or filter	Inspect and clean or replace
Water is present in fuel	Drain the fuel system and refuel
Fuel valve is out of use	Replace
Old or non-recommended fuel	Replace with new fuel
Fouled or defective spark plug (s)	Inspect plug (s), replace if necessary
No spark to spark plug	Inspect plug (s), verify stop switch is on
Crankcase filled with water or fuel	Immediately see your dealer
Overuse of choke	Inspect, clean and/or replace spark plugs
Clogged fuel injector	Clean or replace new fuel injector
Low battery voltage	Recharge battery to 12.8 Vdc
Mechanical failure	See your dealer

VEHICLE DIAGNOSIS

Engine Backfires

Fail Reason	How To Avoid Failure
Weak spark from spark plugs	Inspect, clean and/or replace spark plugs
Incorrect spark plug gap or heat range	Set gap to specs or replace plugs
Old or non-recommended fuel	Replace with new fuel
Incorrectly installed spark plug wires	See your dealer
Incorrect ignition timing	See your dealer
Mechanical failure	See your dealer

Engine Runs Irregularly, Stalls or Misfires

Fail Reason	How To Avoid Failure
Fouled or defective spark plugs	Replace with recommended fuel
Worn or defective spark plug wires	See your dealer
Incorrect spark plug gap or heat range	Set gap to specs or replace plugs
Loose ignition connections	Check all connections and tighten
Water present in fuel	Replace with new fuel
Low battery voltage	Recharge battery to 12.8 Vdc

VEHICLE DIAGNOSIS

Engine Runs Irregularly, Stalls or Misfires

Fail Reason	How To Avoid Failure
Kinked or plugged fuel vent line	Inspect and replace
Incorrect fuel	Replace with recommended fuel
Clogged air filter	Inspect and clean or replace
Reverse speed limiter malfunction	See your dealer
Electronic throttle control malfunction	See your dealer
Other mechanical failure	See your dealer
Possible Lean or Rich Fuel Mixture Cause	Solution
Low or contaminated fuel	Add or change fuel, clean the fuel system
Low octane fuel	Replace with recommended fuel
Clogged fuel filter	Replace filter
Fuel is very high octane	Replace with lower octane fuel

VEHICLE DIAGNOSIS

Engine Stops or Loses Power

Fail Reason	How To Avoid Failure
Out of fuel	Refuel
Kinked or plugged fuel vent line	Inspect and replace
Water present in fuel	Replace with new fuel
Fouled or defective spark plugs	Inspect, clean and/or replace spark plugs
Worn or defective spark plug wires	See your dealer
Incorrect spark plug gap or heat range	Set gap to specs or replace plugs
Loose ignition connections	Check all connections and tighten
Low battery voltage	Recharge battery to 12.8 Vdc
Clogged air filter	Inspect and clean or replace
Reverse speed limiter malfunction	See your dealer
Electronic throttle control malfunction	See your dealer
Other mechanical failure	See your dealer

VEHICLE DIAGNOSIS

EFI Malfunction Indicator Light

The Electronic Fuel Injection system on your vehicle contains a self-diagnostic feature that will illuminate the malfunction indicator light (MIL) if it detects a problem. When this indicator is on, the fault code will display on the dashboard directly, record the fault code and contact your dealer for diagnosing. Your dealer has the EFI tool required to diagnose, repair and clear trouble codes.

During normal operation, the EFI indicator will be of

NOTE: The 16-Pin OBD-style connector (located under the front access cover) includes an OBD cap with an internal jumper circuit. The OBD cap must remain in place, or it will lead to no display of the engine RPM or coolant temperature. Do not lose the cap or misplace it.

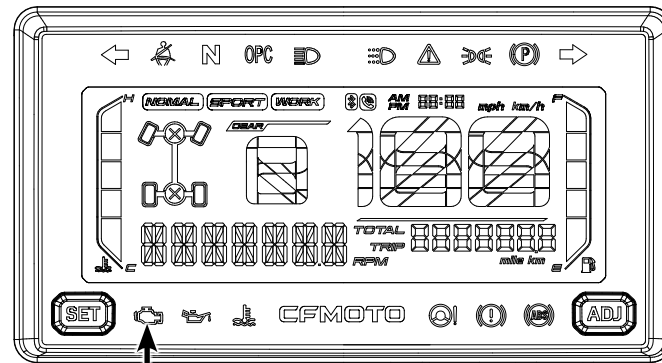

EFI Malfunction Indicator

VEHICLE DIAGNOSIS

EPS Malfunction Indicator Light

The Electronic Power Steering system **1** on your vehicle contains a self-diagnostic feature that will illuminate the malfunction indicator light (MIL- **2**) if it detects a problem. In normal operation, the EPS indicator **2** will be on after the ignition switch is turned to ON, but EPS **1** will not work. When the engine is started, the EPS indicator will be off and the EPS starts to function.

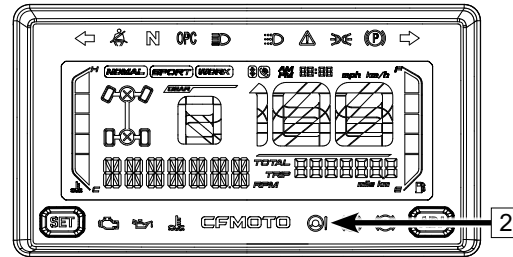
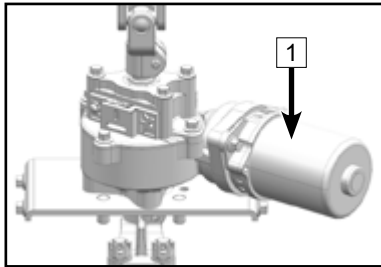

Trouble Code

Each trouble code consists of 2 digits, denoted by the times of long flash and short flash of EPS indicator. Times of long flash represent the tens digit.

Times of short flash represent the single digit.

Duration of long flash: 2 sec.

Duration of short flash: 1 sec.

Flash interval: 1 sec.

The flash cycle will repeat after EPS indicator turns off for 3 seconds. Write down the flash sequence and contact your dealer for diagnosis. Your dealer has the special tool required to diagnose, repair and clear trouble codes. Any codes will disappear once the problem has been diagnosed and repaired by your dealer.

VEHICLE DIAGNOSIS

EPS fault diagnosis and solution

Ref No	Trouble shooting	Possible causes	Repair procedures
1	No steering assist to handlebar	Improper plug connection	Check the plugs and connections
		Burnt fuse	Replace fuse
		Failure of Controller, Motor or sensor	Contact authorized dealer and replace the parts.
2	Asymmetrical steering assist to left and right turning	Improper voltage output from sensor	Contact authorized dealer for adjustment or replacement
		Controller, Motor or sensor break down	Contact authorized dealer and replace the parts.
3	Steering swing	Wrong connections at motor terminals	Change the terminal connection of the red and black wire
		Controller or sensor break down	Contact authorized dealer for parts and replacement
4	Low power steering assist	Overuse of choke	Recharge or replace battery
		Motor break down.	Contact authorized dealer for replacement
		Low pressure with Front tires	Inflate tires to the required pressure
5	Noise from system	Motor break down.	Inspect, clean and/or replace spark plugs
		Steering system parts wear out and big clearance exist.	Replace the related parts.
		Improper assembly of steering column or mechanical steering assembly parts	Check and tighten all of bolts.

CFMOTO LIMITED WARRANTY FOR USA

CFMOTO Limited Warranty For USA

Dear Customer,

Thank you for purchasing a CFMOTO product, if any component on your vehicle is found to be defective in materials or workmanship within the terms and conditions of this Limited Warranty, the defective component will be repaired or replaced (at the option of CFMOTO) without charge for parts and/or labor at any authorized dealer located within the United States. The CFMOTO Limited Warranty is subject to the following terms and conditions:

WARRANTY TERMS & CONDITIONS

1.WARRANTY DURATION: The duration of the warranty period is one (1) year from the date of the new vehicle purchase from an authorized CFMOTO POWERSPORTS, Inc., Dealer. This warranty coverage is invoked from the purchase and use of CFMOTO vehicles only within the continental United States. During the warranty period, CFMOTO POWERSPORTS, Inc. will cover parts and labor costs incurred by an authorized CFMOTO POWERSPORTS, Inc. Dealer arising from a defect in material and/or workmanship of a CFMOTO vehicle. Any vehicles used for commercial purposes will have their warranty period reduced to six (6) months. If CFMOTO POWERSPORTS, Inc. covers a full engine replacement or a complete vehicle replacement under this warranty, the warranty period does not get extended and remains the same as the original purchase date of the vehicle at issue.

2.WARRANTY LIMITATIONS: CFMOTO POWERSPORTS, Inc. provides warranty coverage for one (1) year on all parts and labor for all of its new CFMOTO ATVs. However, the following coverage, exceptions, and limitations apply to all CFMOTO vehicles:

CFMOTO LIMITED WARRANTY FOR USA

- A. A 30-DAY WARRANTY coverage period applies to all new CFMOTO vehicles in relation to the vehicle's:
- Battery
 - Spark Plugs
 - Air Filters
 - Oil and Fuel Filters
- B. A 90-DAY WARRANTY coverage period applies to all new CFMOTO vehicles in relation to the vehicle's:
- Drive Belt
 - Gear Shift, CVT, and Wet Clutch
 - Throttle and Brake Cables
 - Front/Rear Rims
 - Front/Rear Tires
 - Front/United Brake Pads or Shoes
 - Front/United Brake Discs or Drums
 - Wheel or Steering Stem Bearings and Seals
 - Rubber Parts/Engine Mounts/Grips/Boots
 - Brake or Clutch Levers
 - Floor Boards or Pegs
 - ATV Winch (if equipped)
 - Light Bulbs/Fuses
 - Body Plastics and Cosmetic Defects

CFMOTO LIMITED WARRANTY FOR USA

3.EXCLUSIONS FROM WARRANTY COVERAGE: Any Damage resulting from the following acts or circumstances is not covered by the CFMOTO POWERSPORTS, Inc., Limited Warranty:

- Fire
- Collision
- Theft
- Unavoidable natural disasters
- Improper storage or transportation
- Failure or negligence in the performance of periodic vehicle maintenance
- Improper or negligent use or operation
- Unauthorized repair or adjustment
- Unauthorized modifications or performance upgrades
- Use of vehicle as a rental vehicle
- Use of vehicle in competitive or racing events

4.VEHICLE CARE AND MAINTENANCE: The vehicle's owner must properly use, maintain, and care for the vehicle as outlined in the CFMOTO POWERSPORTS, Inc., Owner's Manual. Any warranty repairs must be performed exclusively by CFMOTO POWERSPORTS, Inc., authorized Dealers. Any warranty work performed by anyone other than an authorized CFMOTO Dealer will not be covered under the CFMOTO POWERSPORTS, Inc., Limited Warranty policy.

CFMOTO LIMITED WARRANTY FOR USA

5.TRANSFER OR CONTINUATION OF WARRANTY: This warranty is transferable only under the following conditions:

- Transfer information must be provided to an authorized CFMOTO POWERSPORT S, Inc. dealer, who will then forward the information to CFMOTO POWERSPORTS, Inc..
- The complete model and serial number as shown on the original warranty document must be Provided.
- The name and address of the existing and new owners must be provided.
- The original delivery date of the vehicle must be provided.
- The new owner must indicate in writing that he/she has received and read the vehicle's Owner's Manual and the CFMOTO POWERSPORTS, Inc. Warranty Policy.

6.WARRANTY REGISTRATION: The Dealer must complete a PDI form and warranty register the vehicle online and provide the completed registration form to CFMOTO POWERSPORTS, Inc., within seven (7) days of completing the sale of the vehicle. Please note that NO warranty claims will be processed unless the product warranty online registration form is completed and the form is received by CFMOTO POWERSPORTS, Inc., from the Dealer.

7.DEALER RESPONSIBILITIES: A CFMOTO authorized Dealer must perform warranty coverage repairs at no charge to the customer, even if they are not the dealer that sold the CFMOTO vehicle to the customer and must use CFMOTO OEM parts for all warranty repairs. All vehicles sold by the dealer must be inspected and tested by the dealer to ensure proper performance and operation prior to delivery to the customer. No vehicles may be delivered to a customer without first passing a dealer inspection and an operational test.

CFMOTO LIMITED WARRANTY FOR USA

8.CUSTOMER ASSISTANCE: Any questions regarding your CFMOTO vehicle or related products should be directed to an authorized CFMOTO dealer. However, if a dealer is not available to answer customer concerns or address a technical issue with a CFMOTO vehicle or product, CFMOTO POWERSPORTS, Inc., customer representatives can be contacted directly at (763) 398-2690 or by e-mail: info@cfmoto-us.com. Please note that Customer Service cannot approve or deny warranty, and cannot provide technical repair data, diagnosis, instruction, or other information beyond what is provided in the Owner's Manual.

9.COMMERCIAL USE. The duration of the warranty for commercial use shall be limited to a period of six (6) months instead of one year for recreational use. All other conditions and limitations shall apply.

10.TIRES PROVIDED AS ORIGINAL EQUIPMENT: Other than provided herein, vehicle tires supplied as original equipment are warranted separately by the individual tire manufacturer or its representatives.

11.DISCLAIMER: NO EXPRESS WARRANTY IS PROVIDED BY CFMOTO POWERSPORTS, INC. WITH RESPECT TO CFMOTO VEHICLES EXCEPT AS SPECIFICALLY SET FORTH HEREIN. ANY IMPLIED WARRANTY, WARRANTY OF MERCHANTABILITY, WARRANTY OF FITNESS FOR A PARTICULAR PURPOSE, AND ALL IMPLIED WARRANTIES ARISING FROM A COURSE OF DEALING, USAGE OF TRADE, BY STATUTE OR OTHERWISE, ARE HEREBY STRICTLY LIMITED TO THE TERMS OF THIS WRITTEN LIMITED WARRANTY.

CFMOTO LIMITED WARRANTY FOR USA

12. INTEGRATION: This limited warranty supersedes any and all oral, express, or written warranties, statements, or undertakings that may previously have been made, and contains the entire agreement of the parties with respect to the warranty of CFMOTO vehicles. Any and all warranties not contained in this Agreement are specifically excluded. This warranty extends to each original (and subsequent) owner of any CFMOTO ATV, for the term of the original warranty period. This limited warranty shall be the sole and exclusive remedy available to the customer with respect to the covered CFMOTO vehicle. In the event of any alleged breach of any warranty or any legal action brought by the customer based on alleged negligence or other conduct by CFMOTO POWERSPORTS Inc., or its related parties, the customer's sole and exclusive remedy will be repair or replacement of defective components as stated above, unless otherwise provided by law. Some states do not allow limitations on how long an implied warranty lasts, so the above limitations may not apply if they are deemed inconsistent with the controlling state law.

**CFMOTO LIMITED WARRANTY FOR USA
CALIFORNIA EVAPORATIVE EMISSIONS CONTROL WARRANTY STATEMENT**

YOUR WARRANTY RIGHTS AND OBLIGATIONS

INTRODUCTION:

The California Air Resources Board (CARB) and CFMOTO Powersports, Inc. (CFMOTO) are pleased to explain the evaporative emissions control system warranty on your 2020 and later-model year off-highway recreation vehicles (OHRVs). In California, new off-highway recreational vehicles must be designed, built, and equipped to meet the State's stringent anti-smog standards. CFMOTO must warrant the evaporative emissions control system on your OHRV for the periods of time listed below, provided there has been no abuse, neglect, improper maintenance, or unapproved modification of your OHRV.

Your evaporative emissions control system may include parts such as: fuel injection systems, electronic control systems, fuel tanks, fuel lines, fuel caps, valves, carbon canisters, filters, vapor hoses, belts, clamps, connectors, and other evaporative emissions-related components. Where a warrantable condition exists, CFMOTO will repair your OHRV at no cost to you, including diagnosis, parts and labor.

MANUFACTURER'S WARRANTY COVERAGE:

The warranty period for this OHRV is 30 months, or 2500 miles, or 250 hours, whichever comes first, except for "high-priced" warranty parts, which are covered for 60 months, or 5000 miles, or 500 hours, whichever comes first. If any evaporative emissions-related part on your OHRV is defective, the part will be repaired or replaced by CFMOTO.

OWNER'S WARRANTY RESPONSIBILITIES:

As the OHRV owner, you are responsible for the performance of the required maintenance listed in your owner's manual. CFMOTO recommends that you retain all receipts covering maintenance on your OHRV, but CFMOTO cannot deny warranty solely for the lack of receipts or for your failure to ensure the performance of a scheduled maintenance.

CFMOTO LIMITED WARRANTY FOR USA

As an owner, you are responsible for presenting your OHRV to a CFMOTO dealer as soon as a problem exists. The warranty repairs should be completed in a reasonable amount of time, not to exceed 30 days.

As an OHRV owner, you should also be aware that CFMOTO may deny you warranty coverage if your OHRV or a part has failed due to abuse, neglect, improper maintenance or unapproved modifications.

WARRANTY PARTS:

The repair or replacement of any warranted part otherwise eligible for warranty coverage may be excluded from such coverage if CFMOTO demonstrates that the OHRV has been abused, neglected, or improperly maintained, and that such abuse, neglect, or improper maintenance was the direct cause of the need for repair or replacement of the part. That notwithstanding, any adjustment of a component that has a factory installed, and properly operating, adjustment-limiting device is still eligible for warranty coverage. The following emission warranty parts list are covered:

- Fuel Tank[§]
- Fuel Cap
- Fuel Lines
- Fuel Lines Fittings
- Clamps
- Pressure Relief Valves*
- Control Valves*
- Control Solenoids*
- Electronic Control*
- Electronic Control Module*[§]
- Vacuum Control Diaphragms*
- Control Cables*
- Control Linkages*
- Purge Valves
- Vapor Hoses
- Liquid/Vapor Separator
- Carbon Canister
- Canister Mounting Brackets

*Parts that relate to the installed vehicle Evaporative Control System. [§]High-Priced warranty parts.

CFMOTO LIMITED WARRANTY FOR USA
THE REMOVAL OR MODIFICATION OF EVAPORATIVE EMISSION-RELATED PARTS ON THIS OHRV IS ILLEGAL. VIOLATORS MAY BE SUBJECT TO CIVIL AND/OR CRIMINAL PENALTIES AS PROVIDED UNDER CALIFORNIA AND FEDERAL LAW.

If you have any questions regarding your warranty rights and responsibilities, you should contact CFMOTO at 763 398-2690. 555 Holly Lane N. Suite #30 Plymouth, MN 55447 or the California Air Resources Board at 9528 Telstar Avenue, El Monte, CA 91731.

U.S.A. EPA and CARB Emissions Control Limited Warranty

This emissions limited warranty is in addition to the CFMOTO Powersports, Inc. standard limited warranty for your vehicle. CFMOTO Powersports, Inc. warrants that at the time it is first purchased, this emissions- certified vehicle is designed, built and equipped so it conforms to applicable U.S. Environmental Protection Agency (EPA) and the California Air Resource Board (CARB) emission regulations. CFMOTO Powersports, Inc. also warrants that the vehicle is free from defects in materials and workmanship that would cause it to fail to meet these regulations.

The warranty period for this emissions-certified vehicle starts on the date the vehicle is first purchased and continues for a period of 500 hours of engine operation, 5000 kilometers (3, 100 miles) of vehicle travel, or 30 calendar months from the date of purchase, whichever comes first. This emissions limited warranty covers components whose failure increases the vehicle's regulated emissions, and it covers components of systems whose only purpose is to control emissions. Repairing or replacing other components not covered by this warranty is the responsibility of the vehicle owner. This emissions limited warranty does not cover components whose failure does not increase the vehicle's regulated emissions.

CFMOTO LIMITED WARRANTY FOR USA

For exhaust emissions, emission-related components include any engine parts related to the following systems:

- Air-induction system (excludes filters)
- Fuel system (excludes filters)
- Ignition system (excludes spark plugs)
- Exhaust gas recirculation systems

The following parts are also considered emission-related components for exhaust emissions:

- After treatment devices
- Crankcase ventilation valves
- Sensors
- Electronic control units

The following parts are considered emission-related components for evaporative emissions:

- Fuel Tank
- Fuel Cap
- Fuel Line
- Fuel Line Fittings
- Clamps*
- Pressure Relief Valves*
- Control Valves*
- Control Solenoids*
- Electronic Controls*
- Vacuum Control Diaphragms*
- Control Cables*
- Control Linkages*
- Purge Valves
- Vapor Hoses
- Liquid/Vapor Separator
- Carbon Canister
- Canister Mounting Brackets
- Carburetor Purge Port Connector

* As related to the evaporative emission control system.

The exclusive remedy for breach of this limited warranty shall be, at the exclusive option of CFMOTO Powersports, Inc., repair or replacement of any defective materials, components or products.

CFMOTO LIMITED WARRANTY FOR USA

THE REMEDIES SET FORTH IN THIS LIMITED WARRANTY ARE THE ONLY REMEDIES AVAILABLE TO ANY PERSON FOR BREACH OF THIS WARRANTY. CFMOTO POWERSPORTS, INC. SHALL HAVE NO LIABILITY TO ANY PERSON FOR INCIDENTAL, CONSEQUENTIAL OR SPECIAL DAMAGES OF ANY DESCRIPTION, WHETHER ARISING OUT OF EXPRESS OR IMPLIED WARRANTY OR ANY OTHER CONTRACT, NEGLIGENCE OR OTHER TORT OR OTHERWISE. THIS EXCLUSION OF CONSEQUENTIAL, INCIDENTAL, AND SPECIAL DAMAGES IS INDEPENDENT FROM AND SHALL SURVIVE ANY FINDING THAT THE EXCLUSIVE REMEDY FAILED OF ITS ESSENTIAL PURPOSE.

ALL IMPLIED WARRANTIES (INCLUDING BUT NOT LIMITED TO ANY IMPLIED WARRANTIES OF MERCHANTABILITY AND FITNESS FOR A PARTICULAR PURPOSE) ARE LIMITED IN DURATION TO THE WARRANTY PERIOD DESCRIBED HEREIN. CFMOTO POWERSPORTS, INC. DISCLAIMS ALL EXPRESS WARRANTIES NOT STATED IN THIS WARRANTY.

CFMOTO LIMITED WARRANTY FOR USA

Some states do not allow limitations on how long an implied warranty lasts, so the above limitation may not apply if it is inconsistent with the controlling state law. This limited warranty excludes failures not caused by a defect in material or workmanship. This limited warranty does not cover damage due to accidents, abuse or improper handling, maintenance or use. This limited warranty also does not cover any engine that has been structurally altered, or when the vehicle has been used in racing competition. This limited warranty also does not cover physical damage, corrosion, or defects caused by fire, explosions or other similar causes beyond the control of CFMOTO Powersports, Inc. Owners are responsible for performing the scheduled maintenance identified in the owner's manual. CFMOTO Powersports, Inc. may deny warranty claims for failures that have been caused by the owner's or operator's improper maintenance or use, by accidents for which CFMOTO Powersports, Inc. has no responsibility, or by acts of God. Any qualified repair shop or person may maintain, replace, or repair the emission control devices or systems on your vehicle. CFMOTO Powersports, Inc. recommends that you contact an authorized CFMOTO Powersports, Inc. dealer to perform any service that may be necessary for your vehicle. CFMOTO Powersports, Inc. also recommends that you use only genuine CFMOTO Powersports, Inc. parts. It is a potential violation of the Clean Air Act if a part supplied by an aftermarket parts manufacturer reduces the effectiveness of the vehicle's emission controls. Tampering with emission controls is prohibited by federal law. If you have any questions regarding your warranty rights and responsibilities, please contact CFMOTO Powersports, Inc. at 888-823-6686.

CFMOTO LIMITED WARRANTY FOR USA

Noise Control System and Tampering

Warranty time period: 1, 865 miles (3000 km)

Federal law prohibits the following acts or causing thereof:

(1)The removal or rendering inoperative by any person other than for purposes of maintenance, repair, or replacement, of any device or element of design incorporated into any new vehicle for the purpose of noise control prior to its sale or delivery to the ultimate purchaser or while it is in use or.

(2)The use of the vehicle after such device or element of design has been removed or rendered inoperative by any person.

AMONG THOSE ACTS PRESUMED TO CONSTITUTE TAMPERING ARE THE ACTS LISTED BELOW:
These acts include tampering with the following systems. i.e., modification, removal, etc.

Exhaust system

- Muffler
- Exhaust
- Silencer

Intake system

- Air cleaner case
- Air cleaner element
- Intake duct

CHANGE OF OWNERSHIP

If you sell the product, any valid remainder of the warranty can be transferred to the new Owner. Please record the details of the exchange below and inform an Authorized CFMOTO Dealer.

REGISTRATION OF CHANGE OF OWNERSHIP	2nd OWNER	3rd OWNER	4th OWNER
OWNER'S NAME			
ADDRESS			
TOWN/CITY			
STATE-ZIP			
TELEPHONE			
E-MAIL			
DATE OF PURCHASE			
ODOMETER READING			
NEW OWNER SIGNATURE			



⚠ WARNING

Improper ATV use can result in SEVERE INJURY or DEATH.



ALWAYS USE AN APPROVED HELMET AND PROTECTIVE GEAR



NEVER USE ON PUBLIC ROADS



NEVER CARRY PASSENGERS



NEVER USE WITH DRUGS OR ALCOHOL

NEVER operate :

- without proper training or instruction.
- at speeds too fast for your skills or the conditions.
- on public roads - a collision can occur with another vehicle.
- with a passenger - passengers affect balance and steering and increase risk of losing control.

ALWAYS :

- use proper riding techniques to avoid vehicle overturns on hills and rough terrain and in turns.
- avoid paved surfaces - pavement may seriously affect handling and control.

LOCATE AND READ OWNER'S MANUAL. FOLLOW ALL INSTRUCTIONS AND WARNINGS.

9DS3-190004-6000 US196

TYPE I

⚠ WARNING

Improper use can result in SEVERE INJURY or DEATH



ALWAYS USE AN APPROVED HELMET AND PROTECTIVE GEAR FOR DRIVER AND PASSENGER



NEVER USE ON PUBLIC ROADS



NEVER CARRY MORE THAN 1 PASSENGER



NEVER USE WITH DRUGS OR ALCOHOL

NEVER operate :

- without proper ATV training or instruction.
- at speeds too fast for your skills or the conditions.
- on public roads - a collision can occur with another vehicle.
- with a passenger unless passenger seat is securely in place.

THE OPERATOR MUST ALWAYS:

- use proper riding techniques to avoid overturns on hills and rough terrain and in turns
- avoid paved surfaces - pavement may seriously affect handling and control
- reduce speed and use extra caution at all times when carrying a passenger - dismount passenger when conditions require
- make sure passenger reads and understands this label and passenger safety label

LOCATE AND READ OPERATOR'S MANUAL. FOLLOW ALL INSTRUCTIONS AND WARNINGS

9CS3-190004-6400 US196

TYPE II

**MANUFACTURER:
ZHEJIANG CFMOTO POWER CO., LTD.**

Add: NO.116, Wuzhou Road, Yuhang Economic Development Zone, Hangzhou 311100, Zhejiang Province, China
Tel: 86-571-86258863 Fax: +86-571-89265788
E-mail: service@cfmoto.com.cn <http://global.cfmoto.com>

**DISTRIBUTED BY:
CFMOTO POWERSPORTS INC.**

3555 Holly Lane N. Suite #30, Plymouth MN, 55447, USA
Toll free: (888) 8-CFMOTO (823-6686)
Tel: (1) 763-398-2690 Fax: (1) 763-398-2695
www.cfmotousa.com

**DISTRIBUTED BY:
CANADA MOTOR IMPORT INC.**

24 rue Industrielle, Saint-Benoit Labre,
Québec, Canada, G0M 1P0
Tel: 418-227-2077
www.cfmoto.ca